

FXC

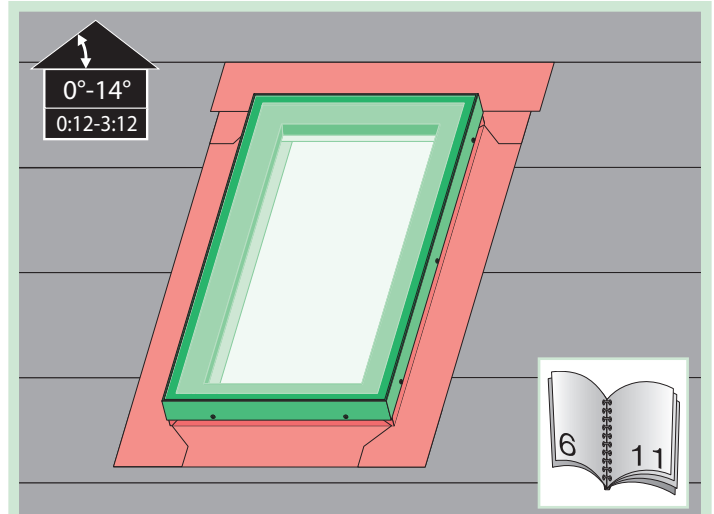

US FXC installation on a flat roof 0°-14°.
 FR FXC installation sur toit plat 0°-14°.
 ES Instalación de FXC en losa plana de 0-14 grados de inclinación.
 KR 0°-14° 사이의 평지붕에서의 FXC 설치.

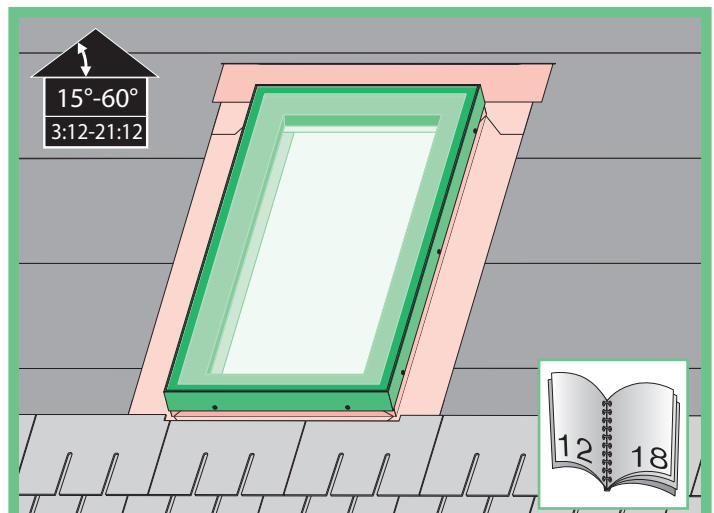

US FXC installation on pitched roof with shingles.
 FR Installation du modèle FXC sur un toit en contreplaqué avec matériau de toiture plat.
 ES Instalación en un techo de madera triplay con material de techo plano.
 KR 평평한 지붕재가 있는 합판 지붕에 FXC를 설치.

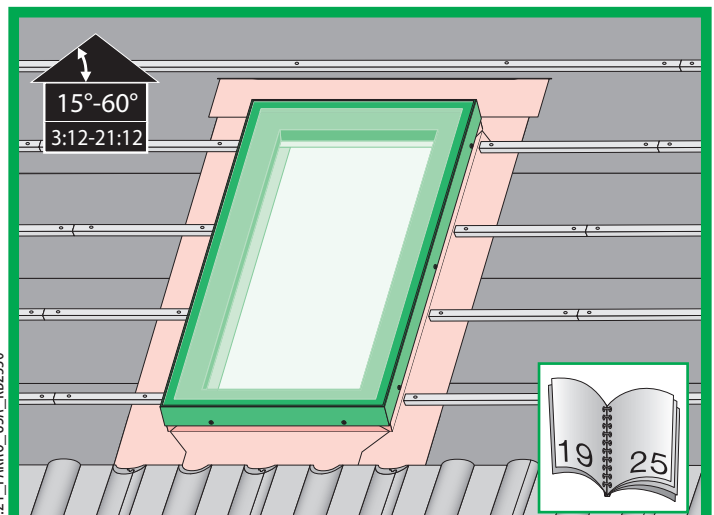

US FXC installation on pitched roof with profiled roofing material.
 FR Installation du modèle FXC sur un toit avec matériau de toiture profilé.
 ES Instalación en un techo con material de techo perfilado.
 KR 프로파일 지붕 재료가있는 지붕에 FXC를 설치.

NC1EP_FXC_20.10.21_FAKRO_USA_KB2330

US	Manufacturer and Seller shall bear no liability for failure to comply with the applicable laws, building codes and safety requirements by the user of the product, architect, fitter or owner of the building.
FR	Le fabricant et le revendeur ne prend aucune responsabilité de ne pas respecter les lois applicables, les règlements sur les bâtiments et les exigences de sécurité par l'utilisateur du produit, l'architecte, l'installateur ou le propriétaire du bâtiment.
ES	El fabricante y el vendedor no tienen ninguna responsabilidad por el incumplimiento de la ley vigente, normas de construcción y exigencias de seguridad por parte del usuario del producto, arquitecto, instalador o el propietario del edificio.
KR	소비자, 건물주, 설계자, 설치자가 요구하는 법규, 규정, 안전조치에 부합하지 않는 것에 대해 제조사나 판매자는 법적 책임이 없습니다.

		14/30	14/46	22/22
Outside curb (WxR)	in mm	17 1/2 x 33 1/2 445x851	17 1/2 x 49 1/2 445x1257	25 1/2 x 25 1/2 648x648
Inside curb BxK	in mm	14 1/2 x 30 1/2 368x775	14 1/2 x 46 1/2 368x1181	22 1/2 x 22 1/2 572x572
SxL	in mm	19 1/4 x 35 1/4 488x894	19 1/4 x 51 1/4 488x1300	27 1/4 x 27 1/4 691x691

		22/30	22/34	22/46
Outside curb (WxR)	in mm	25 1/2 x 33 1/2 648x851	25 1/2 x 37 1/2 648x952	25 1/2 x 49 1/2 648x1257
Inside curb BxK	in mm	22 1/2 x 30 1/2 572x775	22 1/2 x 34 1/2 572x876	22 1/2 x 46 1/2 572x1181
SxL	in mm	27 1/4 x 35 1/4 691x894	27 1/4 x 39 1/8 691x995	27 1/4 x 51 1/4 691x1300

		22/70	30/30	30/46
Outside curb (WxR)	in mm	25 1/2 x 73 1/2 648x1867	33 1/2 x 33 1/2 851x851	33 1/2 x 49 1/2 851x1257
Inside curb BxK	in mm	22 1/2 x 70 1/2 572x1790	30 1/2 x 30 1/2 775x775	30 1/2 x 46 1/2 775x1181
SxL	in mm	27 1/4 x 75 1/8 691x1909	35 1/4 x 35 1/4 894x894	35 1/4 x 51 1/4 894x1300

		34/34	34/46	46/46
Outside curb (WxR)	in mm	37 1/2 x 37 1/2 952x952	37 1/2 x 49 1/2 952x1257	49 1/2 x 49 1/2 1257x1257
Inside curb BxK	in mm	34 1/2 x 34 1/2 876x876	34 1/2 x 46 1/2 876x1181	46 1/2 x 46 1/2 1181x1181
SxL	in mm	39 1/8 x 39 1/8 995x995	39 1/8 x 51 1/4 995x1300	51 1/4 x 51 1/4 1300x1300

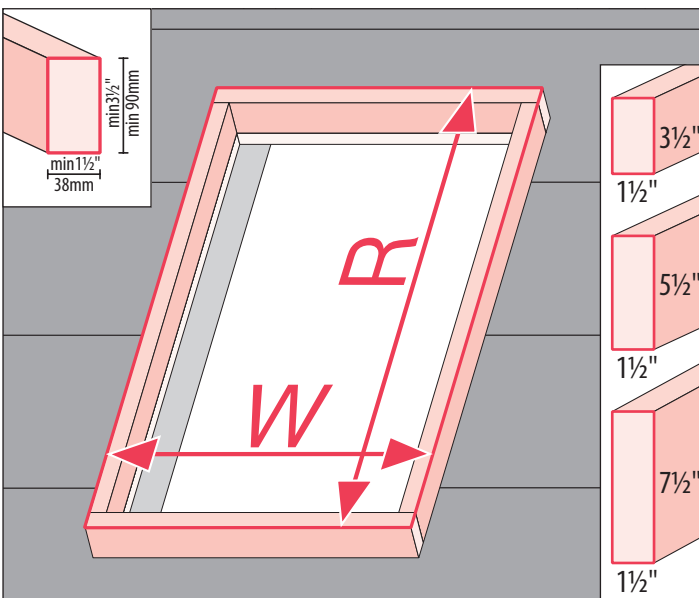
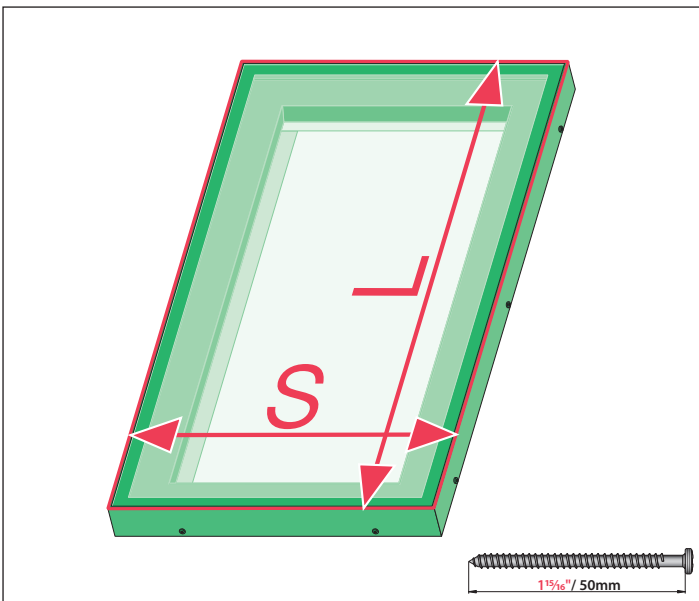

US	Installation by a professional is highly recommended Please review the instructions and carefully follow all the installation steps. Incorrect installation of the skylight will void the warranty.
FR	L'installation par un professionnel est fortement recommandée. Veuillez consulter les instructions et suivre attentivement toutes les étapes de l'installation. Une installation incorrecte du puits de lumière annulera la garantie.
ES	La instalación por un profesional es altamente recomendable. Por favor revise las instrucciones y siga cuidadosamente todos los pasos de instalación. La instalación incorrecta del tragaluz anulará la garantía.
KR	전문가에 의한 설치를 권장함. 설명서를 자세히 읽고 각 단계를 주의 깊게 실행하십시오. 잘못된 천창 설치는 제품에 대한 보증을 무효 시킬 수 있습니다.



US	Do not use silicone
FR	Ne pas utiliser de silicone
ES	No utilice silicon
KR	실리콘을 사용하지 마세요



US	*Special attention guidelines for roof pitch application below 5° Below listed natural physical phenomenon are not covered under FAKRO warranty: - Dripping condensation water that forms on low sloped glass - Stains developed on a glass due to prolong contact with dirt or standing water
FR	* Directives supplémentaires concernant les installations sur une pente de toit de moins de 5 degrés. Les phénomènes naturels suivants ne sont pas couverts par la garantie de FAKRO: - l'égouttement de l'eau causée par la condensation sur le vitrage d'une fenêtre installée sur un toit à faible pente; - les taches sur le vitrage causées par la présence prolongée de saletés ou d'eau stagnante.
ES	*Lineamientos que requieren atención especial para la aplicación en tejados con pendientes menores a 5° En la lista de abajo se describen fenómenos naturales físicos que no se cubren con la garantía de FAKRO: - Gotas de agua de condensación que se forman en el vidrio con inclinación baja - Manchas en el cristal debido a el contacto prolongado con suciedad o agua estancada
KR	5도 이하의 지붕 경사면에서의 설치에 대한 특별 중요 가이드라인 아래에 기재된 자연적 현상들은 Fakro의 보증 범위에서 제외됩니다. 낮은 경사면의 유리에서 결로로 인해 떨어지는 물방울을 오물과 상수에 장기간 접촉하여 창문에 생긴 얼룩.

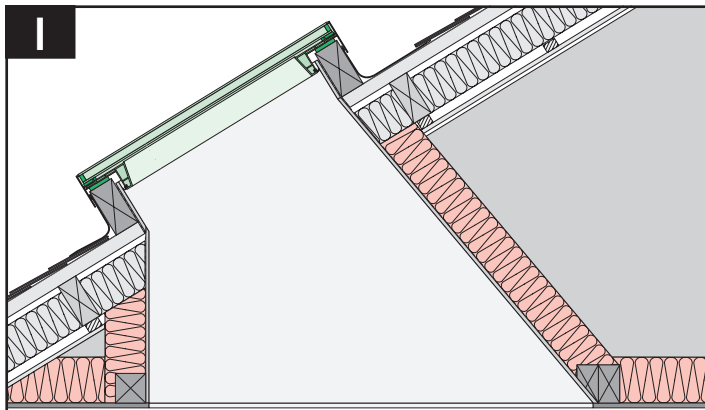

I	
US	<p>PLANNING THE CONSTRUCTION OF A LIGHT SHAFT FOR YOUR FAKRO SKYLIGHT Building a light shaft is an integral part of finishing your FAKRO skylight installation. In the case of home with a flat ceiling it will bring the light through your attic into the room below. Construction of the shaft will govern the light distribution within the room. It is recommended to make the opening in the ceiling larger than the size of the skylight. The purpose is to create both, the visually pleasing effect of a larger room and to distribute the incoming light more widely within the room. Light shafts can also be used to direct light to work spaces such as kitchen benches or mirrored areas in bathrooms. Finishing the light shaft in pale shades or ceiling white will improve the light transmission from your skylight into the room.</p>
FR	<p>PLANIFICATION DE LA FABRICATION D'UN Puits de jour pour votre fenêtre de toit FAKRO La construction d'un puits de lumière fait partie intégrante de l'installation de la fenêtre de toit FAKRO. Dans le cas d'une maison avec un plafond plat, le lanterneau laisse passer la lumière du grenier dans la pièce au-dessous.</p>
ES	<p>PLANIFICANDO LA CONSTRUCCIÓN DE UN CONDUCTO DE LUZ PARA SU TRAGALUZ FAKRO La elaboración de un vano o claro de luz constituye una parte integral para terminar la instalación de un tragaluz FAKRO. En el caso de viviendas con techos planos, el tragaluz permite que la luz del ático entre en la habitación de abajo y su construcción determina la distribución de la luz dentro de la habitación. Se recomienda que la apertura del techo sea mayor que el tragaluz. El propósito del tragaluz es crear un efecto agradable de una habitación de mayor tamaño y propagar la luz que entra en la habitación. Los tragaluz también se pueden usar para dirigir la luz a los espacios de trabajo, tales como alacenas de cocina o espejos en el baño. El acabado del tragaluz en tonos pastel o blancos mejora la transmisión de la luz desde el mismo a la habitación.</p>
KR	<p>파크로 천창을 이용한 채광통로 설계 라이트 샤프트를 짓는 것은 FAKRO 채광창 설치를 끝내기 위해 필수적입니다. 평평한 천장을 가진 집의 경우, 다락방을 통해 아래의 방으로 빛을 가져올 수 있습니다. 샤프트 공사는 실내 배광에 영향을 미칠 것입니다. 천창의 크기보다 크게 만드는 것이 좋습니다. 그 목적은 더 넓은 시각적으로 쾌적한 효과를 만드는 것과 들어오는 빛을 방 안에서 욕실의 반사되는 구역과 같은 작업 공간으로 빛을 향하도록 할 수 있습니다. 연한 색조의 라이트 샤프트와 흰색 천장으로 마무리하면 채광창에서 방으로 들어오는 빛 투과 효과를 향상시킬 수 있습니다.</p>

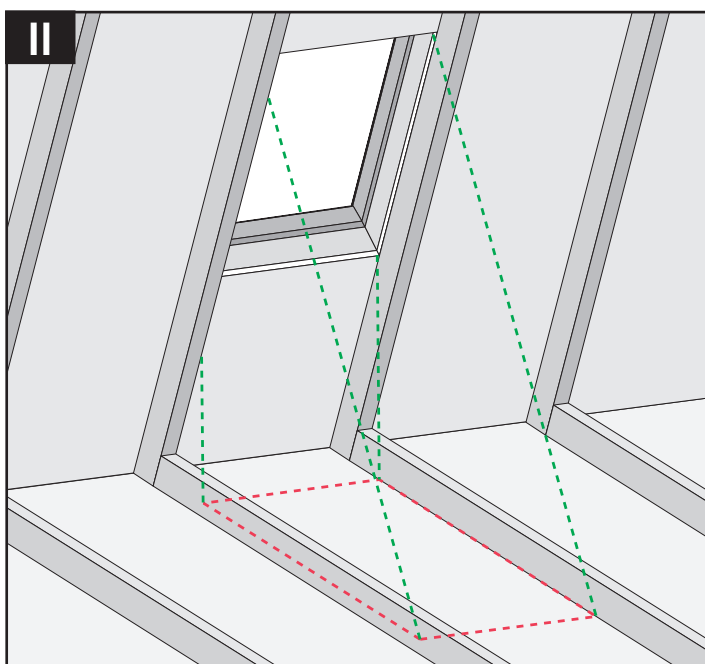

US	Decide the location and size of the light shaft relative to the skylight and the room.
FR	La première étape consiste à sélectionner l'emplacement et la taille du puits de lumière par rapport au lanterneau et à la pièce.
ES	El primer paso consiste en elegir la ubicación y el tamaño del tragaluz con respecto espacio de la habitación.
KR	채광창과 방을 기준으로 라이트 샤프트의 위치와 크기를 결정합니다.

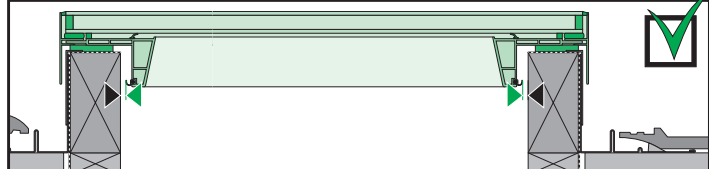
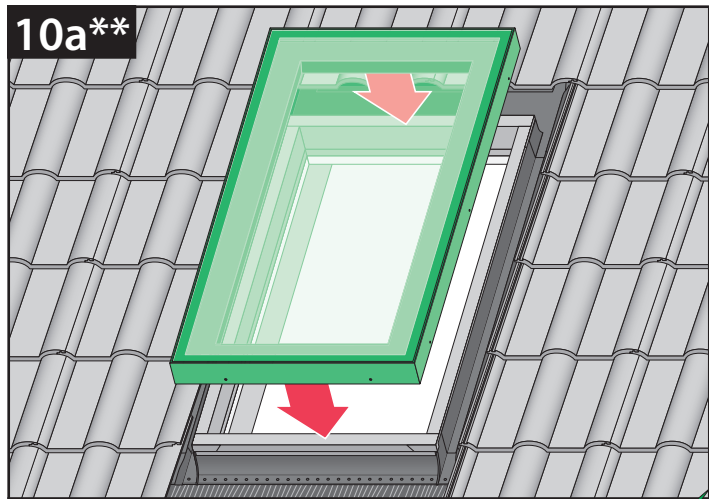

US	Place the FXC skylight over the curb. Watch and make sure the gaps between the inside of the curb and the skylight's frame are equal.
FR	Placez la fenêtre de toit FXC par-dessus la bordure. Vérifiez bien que les espaces entre l'intérieur de la bordure et le cadre de la fenêtre de toit sont égaux.
ES	Coloque el tragaluz FXC sobre la acera. Observe y asegúrese de que los espacios entre el interior de la acera y el marco de tragaluzes son iguales.
KR	커브위에 FXC 천창을 놓습니다. 커브 내부와 천창의 프레임 사이의 간격이 동일한 지 확인하십시오.

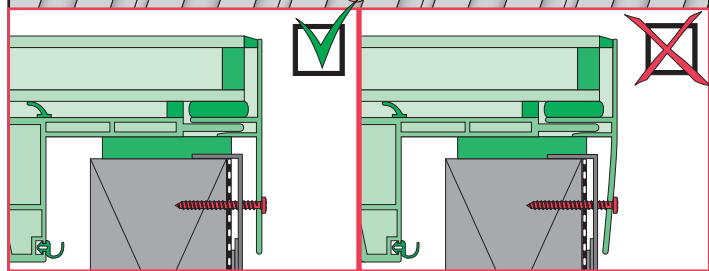
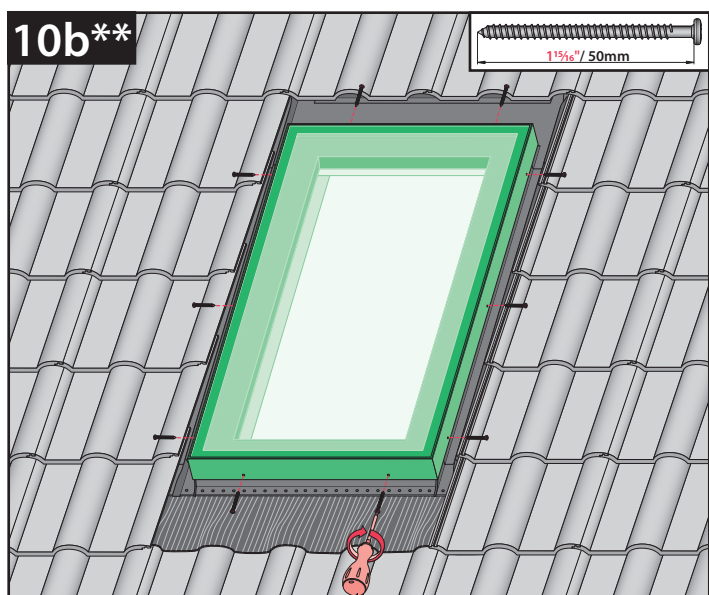

US	Secure the skylight with the screws to the curb. Skylights profile can not deform during tightening the screws.
FR	Attachez le skylight à l'aide de vis de fixation. Le profilé du skylight FXC ne doit pas se déformer pendant la fixation des vis.
ES	Asegure el tragaluz al borde con los tornillos. El perfil del tragaluz FXC no se puede deformar al atornillar.
KR	목재들에 채광창을 나사로 고정하십시오. 나사를 조일 때, 채광창의 프로파일이 변형되어선 안됩니다.

8**

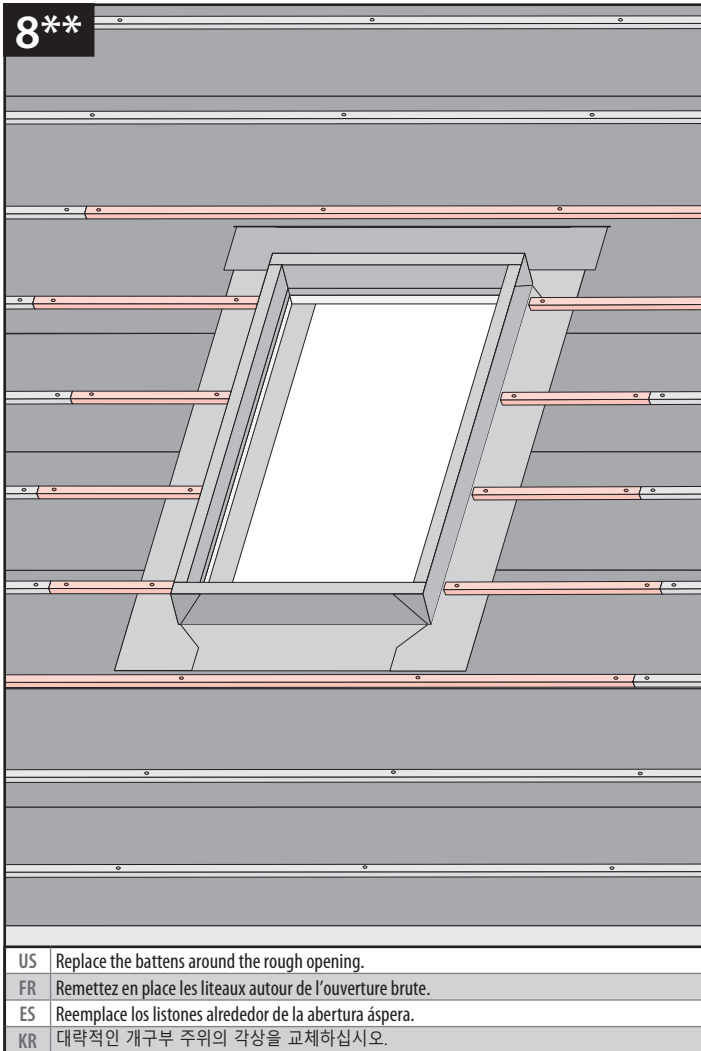

- US Replace the battens around the rough opening.
- FR Remettez en place les liteaux autour de l'ouverture brute.
- ES Reemplace los listones alrededor de la abertura áspera.
- KR 대략적인 개구부 주위의 각상을 교체하십시오.

III

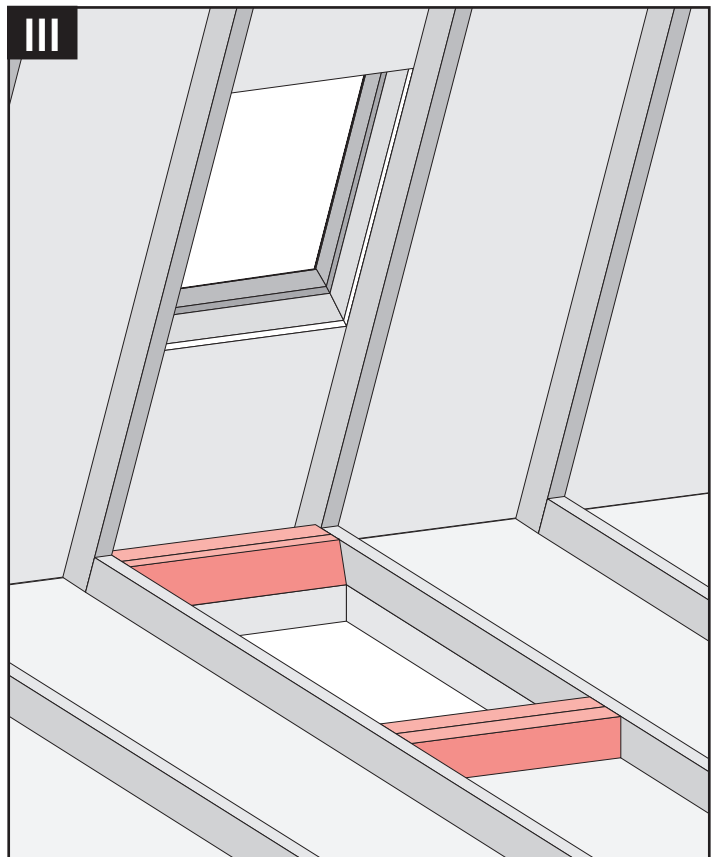

- US Prepare the hole in the ceiling using headers and trimmers. Follow the rules used in roof and wall construction.
- FR Préparer l'ouverture dans le plafond à l'aide des poutres auxiliaires et de plafond. Respecter les règles utilisées dans la construction des toits et des murs.
- ES A continuación, prepare el vano o claro en el techo con ayuda de vigas auxiliares y viguetas. Se deben respetar las normas utilizadas en la construcción de techos y paredes.
- KR 헤더와 트리머를 사용하여 천장에 구멍을 만듭니다. 지붕과 벽 공사에 사용되는 규정을 따릅니다.

9**

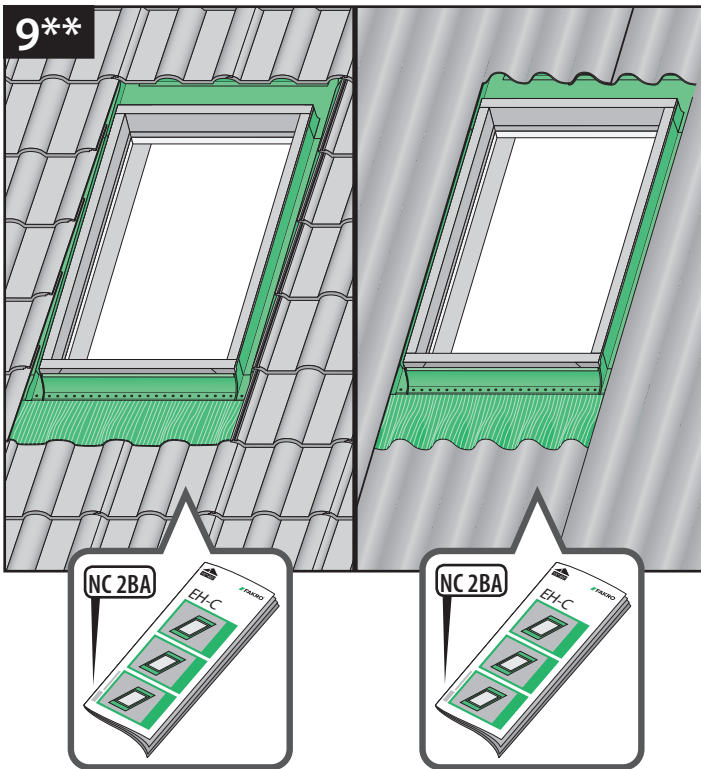

- US Install the EH-C flashing for profiled roofing materials. Installation instructions for flashings come with the flashings.
- FR Installez le solin EH-C pour matériaux de toiture profilés Les instructions d'installation des solins sont livrées avec les solins.
- ES Instale el tapajuntas EH-C y cubra con el material para techos perfilados. Las instrucciones de instalación para los tapajuntas vienen con ellos.
- KR 프로파일링된 지붕재에 EH-C후레싱을 설치하십시오. 후레싱에 대한 설치 지침은 후레싱과 함께 제공됩니다.

IV

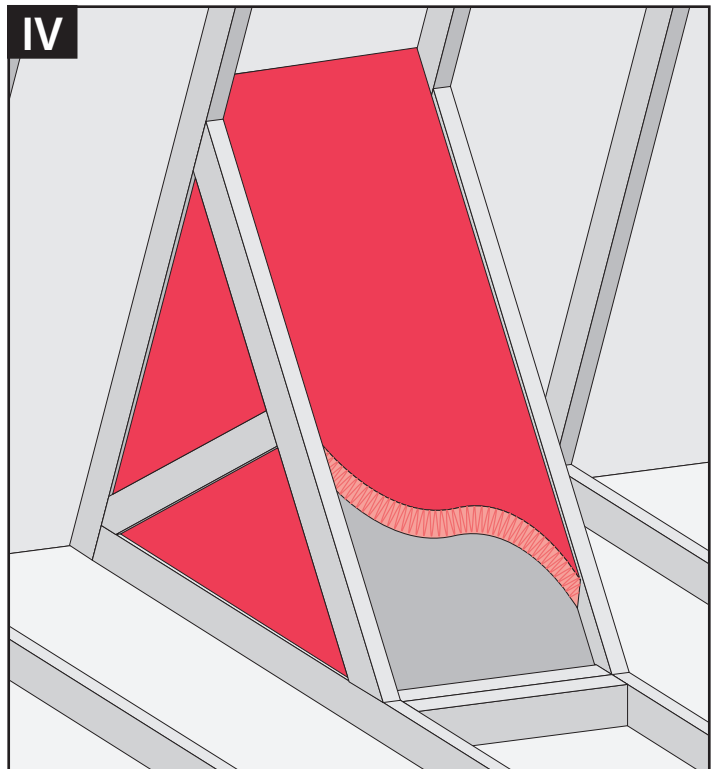

- US Frame out the shaft, line with plasterboard, and ensure that the shaft is clad with roofing insulation in the roof cavity. This will reduce heat transmission from the roof cavity into the home in summer, and help reduce heat loss from the home in winter.
- FR Préparez un cadre au puits, munissez-le d'une plaque de plâtre et assurez-vous que le puits est enveloppé avec l'isolation de la toiture dans la cavité du toit. En été, cela réduira la transmission de chaleur provenant de la cavité du toit vers la maison et aidera à réduire la perte de chaleur en hiver.
- ES Marque los conductos, raye con yeso y asegure que el conducto está revestido con el aislamiento del techo en la cavidad del techo. Esto reducirá la transmisión de calor de la cavidad del techo dentro de la casa en el Verano, y ayuda a reducir la pérdida de calor de la casa en el invierno.
- KR 채광통로 설치를 위한 프레임 세우고 석고보드 등으로 통로 면을 만드세요. 단열재로 채광통로를 감싸세요. 단열재 시공은 여름철 천장의 열기가 실내로 유입되는 것을 줄이고, 겨울철 열 손실을 줄입니다.

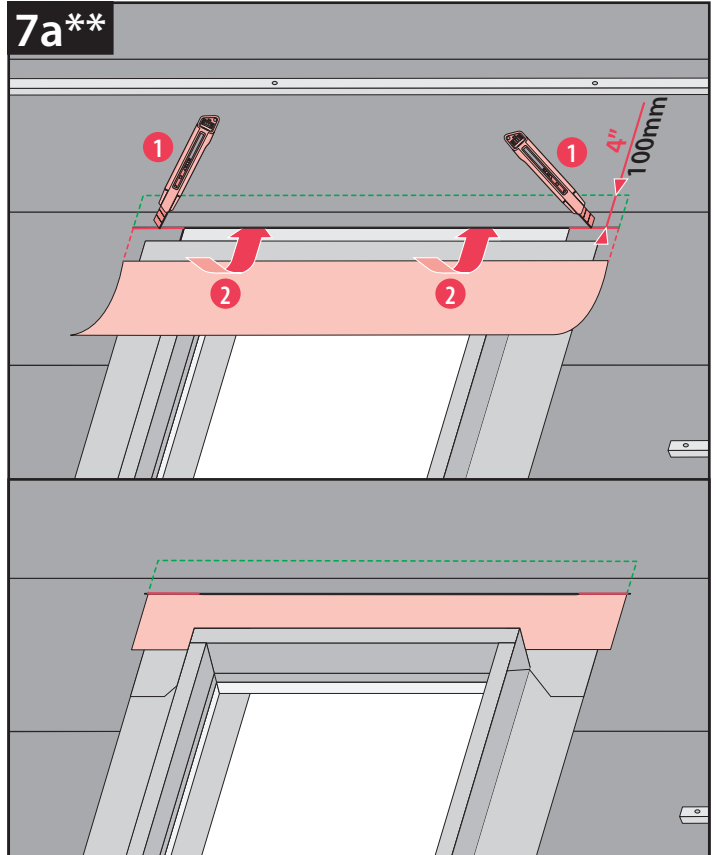
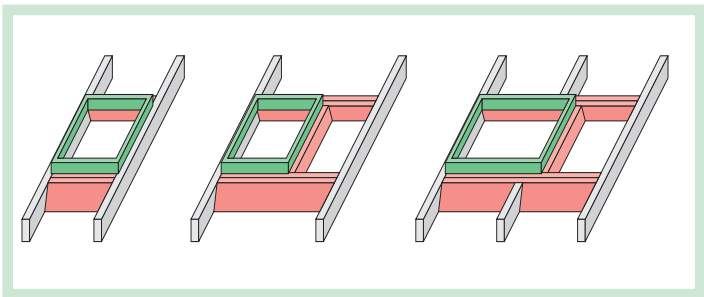
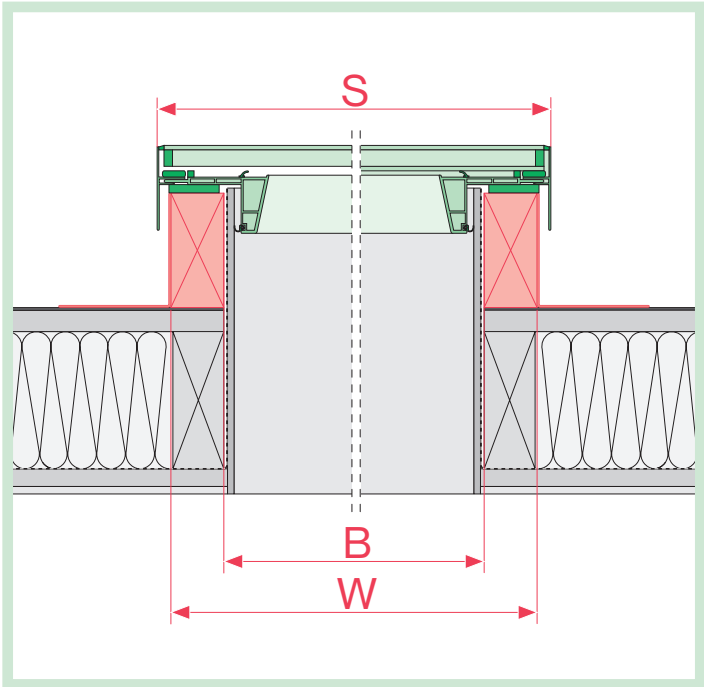
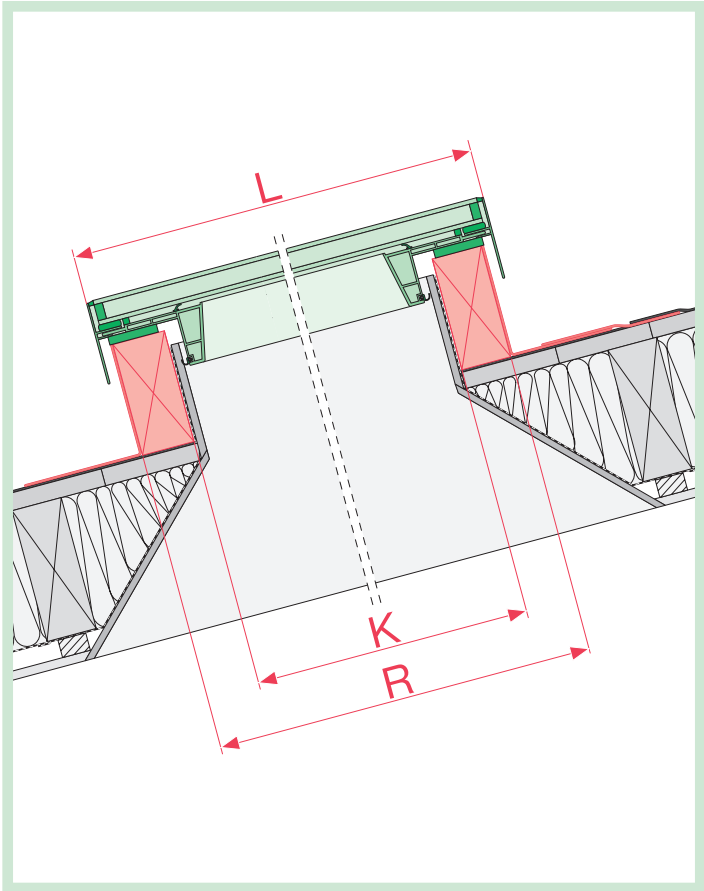
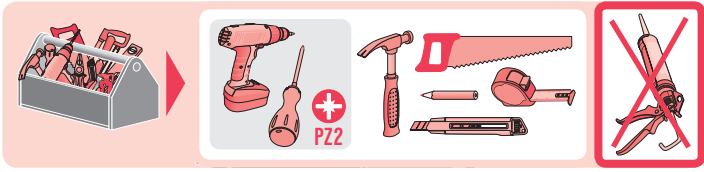

US	To ensure proper water drainage, interweave the skylight's underlayment with the existing roof underlayment (retrofit).
FR	Pour assurer le drainage adéquat de l'eau, entrelacez la sous-couche de la fenêtre de toit avec la sous-couche existante du toit (rénovation).
ES	Para garantizar un drenaje adecuado del agua, entrelace la capa inferior del tragaluz con la nueva capa de techo.
KR	적절한 배수가 되게하려면 천창의 하지재를 기존 지붕하지재에 끼워 넣습니다 (새롭게 장착).

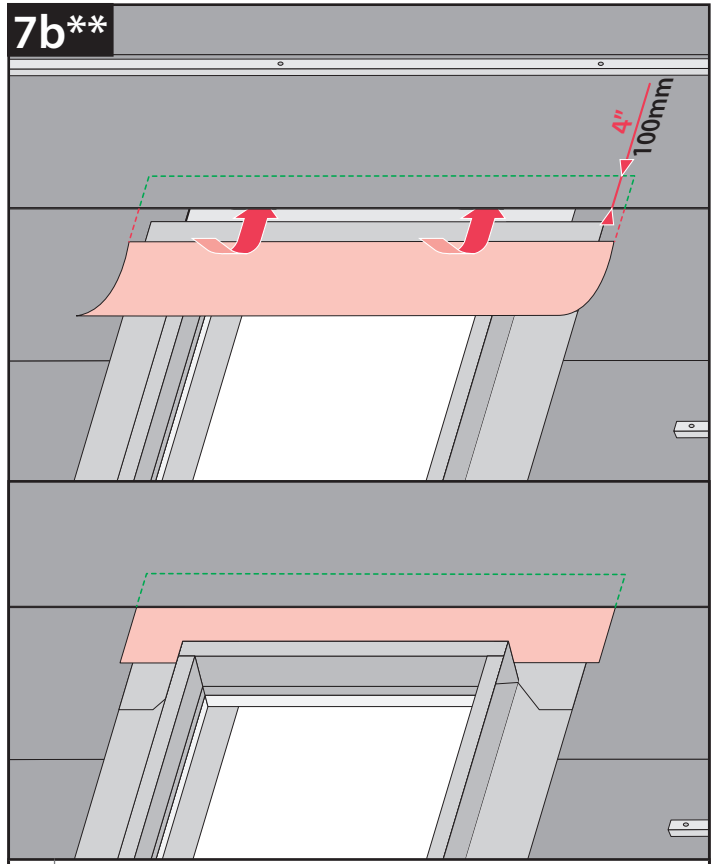

US	To ensure proper water drainage, interweave the skylight's underlayment with the new roof underlayment (new construction).
FR	Pour assurer le drainage adéquat de l'eau, entrelacez la sous-couche de la fenêtre de toit avec la sous-couche neuve (nouvelle construction).
ES	Para garantizar un drenaje adecuado del agua, entrelace la capa inferior del tragaluz con la nueva capa de techo.
KR	적절한 배수가 되게하려면 천창의 하지재를 새로운 지붕하지재에 끼워 넣습니다 (새로운 시공).

5**

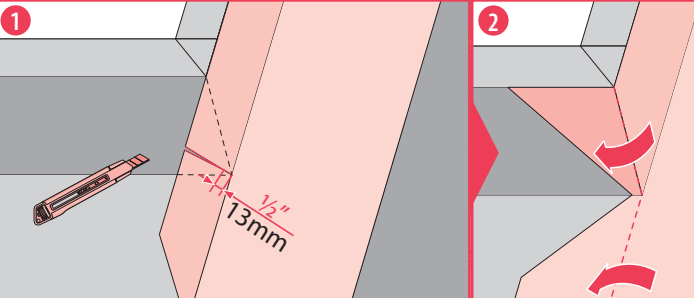
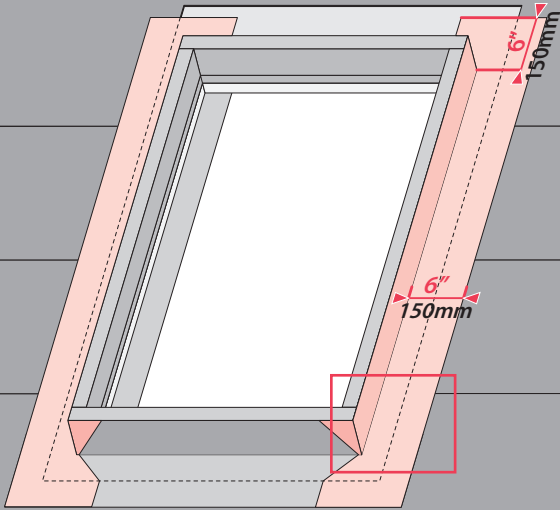

US	Apply self-adhesive underlayment on the sides of the curb.
FR	Appliquez une sous-couche autocollante sur les côtés de la bordure.
ES	Aplicue una capa autoadhesiva en la parte superior de la acera.
KR	커브 측면에 자체 접착성 하지재를 붙이세요.

6**

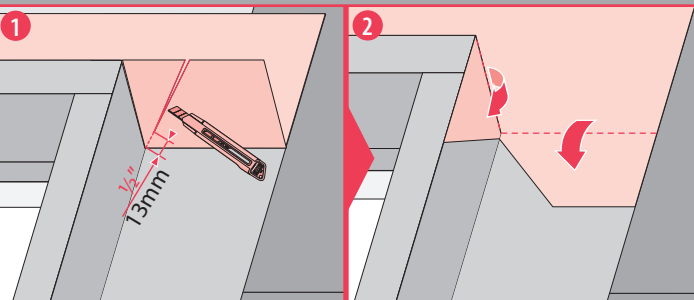
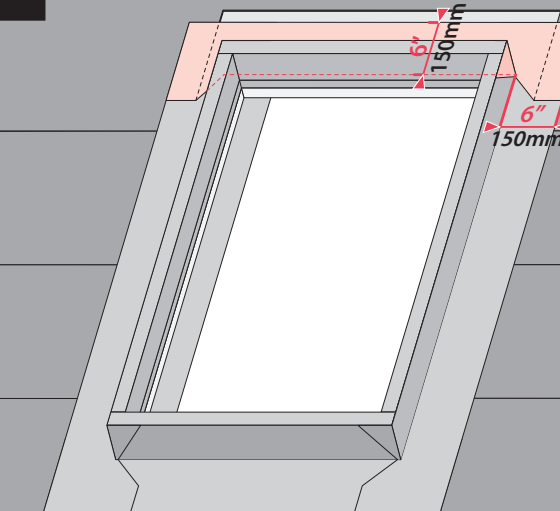

US	Apply self-adhesive underlayment on the top part of the curb.
FR	Appliquez une sous-couche autocollante sur la partie supérieure de la bordure.
ES	Para garantizar un drenaje adecuado del agua, entrelace la capa inferior del tragaluz con la nueva capa de techo.
KR	커브 윗부분에 자체 접착성 하지재를 붙이세요.

1

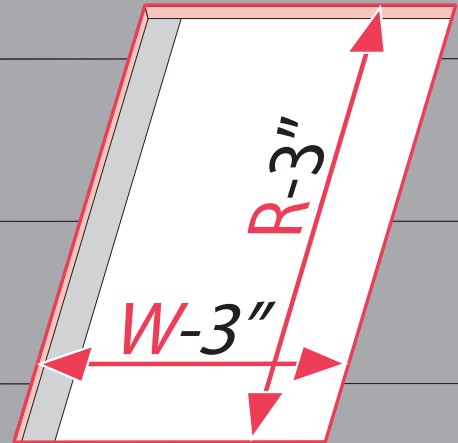

US	Prepare the rough opening in the roof in the dimensions of W-3" i R-3" (dimensions W and R are given in a table on page 2).
FR	Préparez l'ouverture de montage dans le toit conformément aux dimensions W-3" i R-3" (dimensions W et R sont mentionnées dans le tableau sur la page 2).
ES	Préparez l'ouverture de montage dans le toit conformément aux dimensions W-3" i R-3" (dimensions W et R sont mentionnées dans le tableau sur la page 2).
KR	지붕의 W-3" i R-3" 의 위치에 적절한 가로, 세로의 개구부를 준비하십시오.(W-3" i R-3" 의 위치에 적절한 개구부 수치는 2페이지에 표시되어 있습니다.)

2

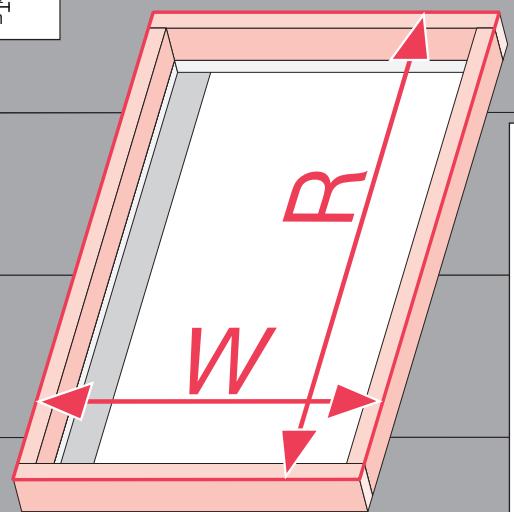
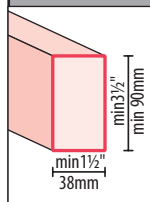

US	Build a curb around the rough opening using a standard 2x4, 2x6 or 2x8 lumber.
FR	Faites construire un "rehaussement" de dimensions 2x4, 2x6 ou 2x8 autour l'ouverture de montage dans le toit.
ES	Construya una borde con dimensiones de 2x4, 2x6 o 2x8 al rededor de la apertura.
KR	개구부 주위에 2x4, 2x6 혹은 2x8 사이즈의 창 고정을 위한 목재들을 설치하십시오.

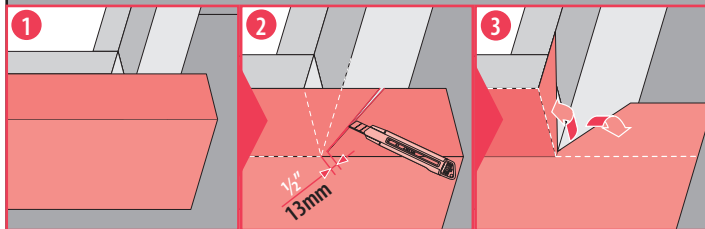
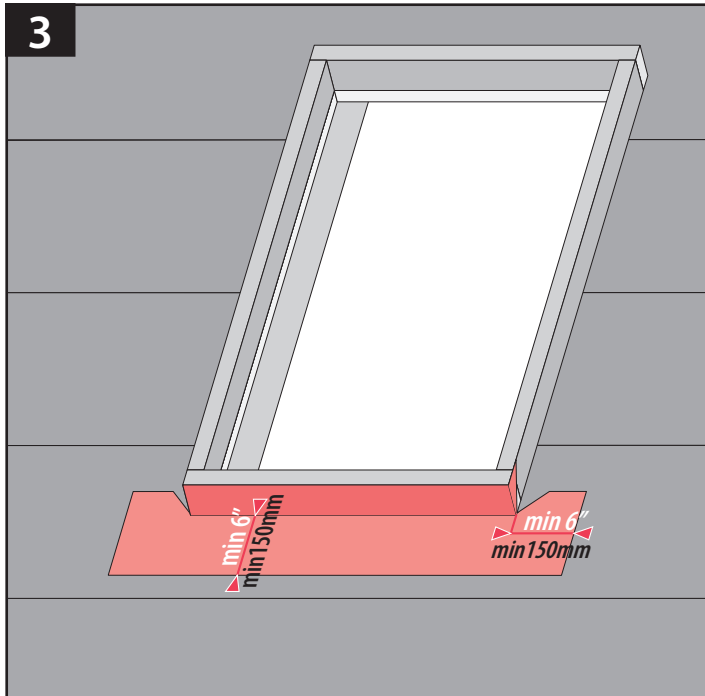

US	For complete waterproofing, apply self-adhesive underlayment at the bottom of the curb.
FR	Afin d'assurer l'étanchéité collez la couche adhésive de la base sur la partie basse du rehaussement.
ES	Para asegurar la impermeabilidad, aplique una capa de autoadhesivo en la parte inferior del borde.
KR	방수기능을 완성하기 위해 자착식 하지재를 그림과 같이 순서대로 목재를 하단에 부착하십시오.

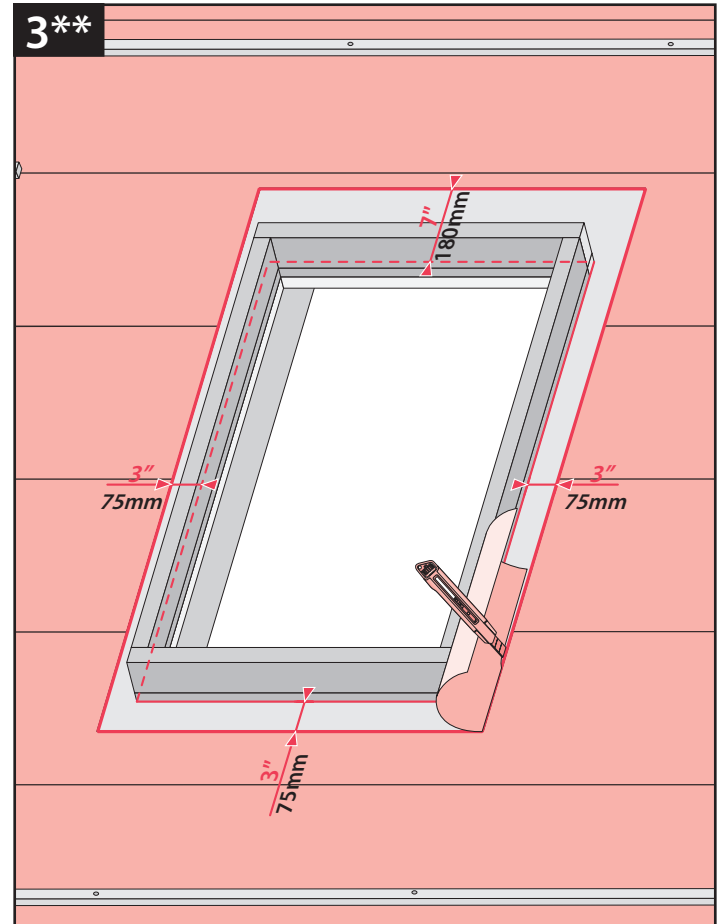

US	Remove existing roofing underlayment around the opening.
FR	Enlevez la sous-couche de toiture existante autour de l'ouverture.
ES	Retire la capa de techo existente alrededor de la abertura.
KR	개구부 주변의 기존 지붕 하지재를 제거하십시오.

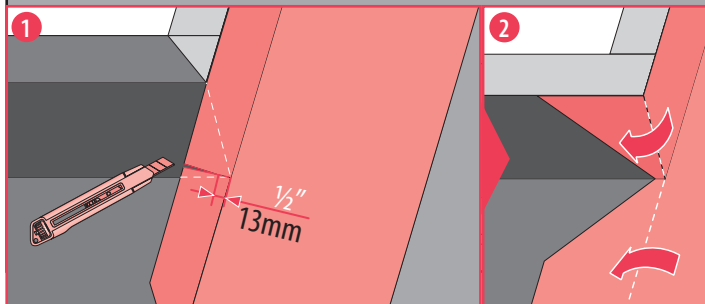
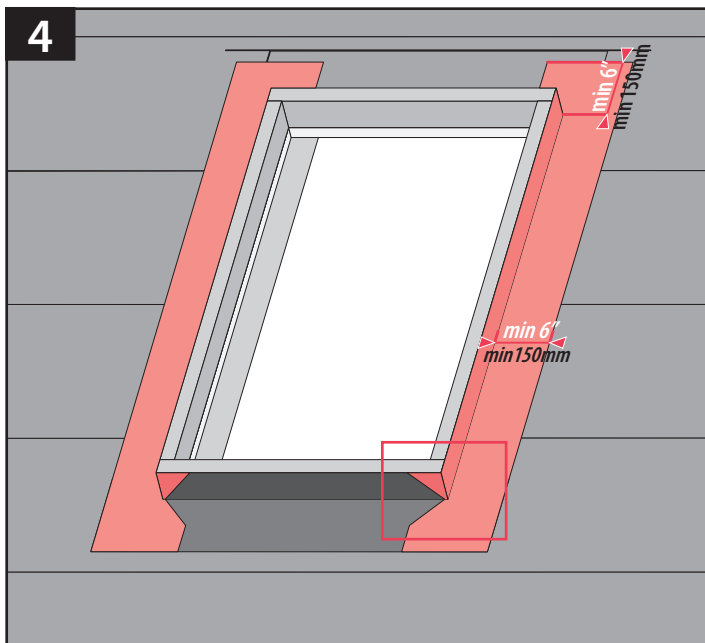

US	Apply self-adhesive underlayment on the sides of the curb.
FR	Appliquez la couche adhésive de la base sur la partie latérale du rehaussement.
ES	Aplique el autoadhesivo en los lados del borde.
KR	자착식 하지재를 그림과 같이 순서대로 목재틀 양 측면에 부착하십시오.

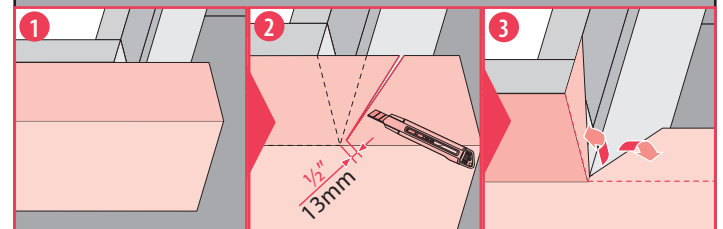
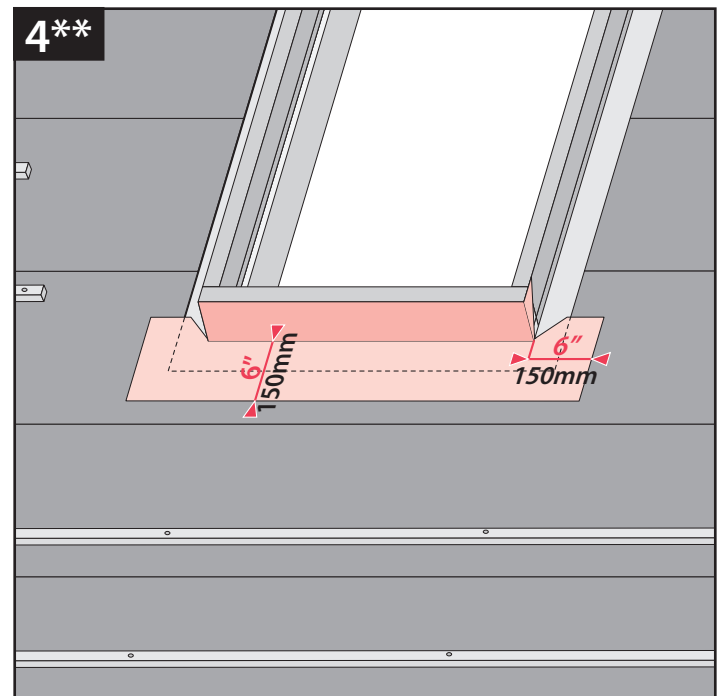

US	For complete waterproofing, apply self-adhesive underlayment at the bottom of the curb.
FR	Pour obtenir une hydrofugation complète, appliquez une sous-couche autocollante en bas de la bordure.
ES	Para una impermeabilización completa, aplique un adhesivo en la parte inferior de la acera.
KR	완벽한 방수 처리를 하려면 커브 아래에 자체 접착성 하지재를 붙이세요.

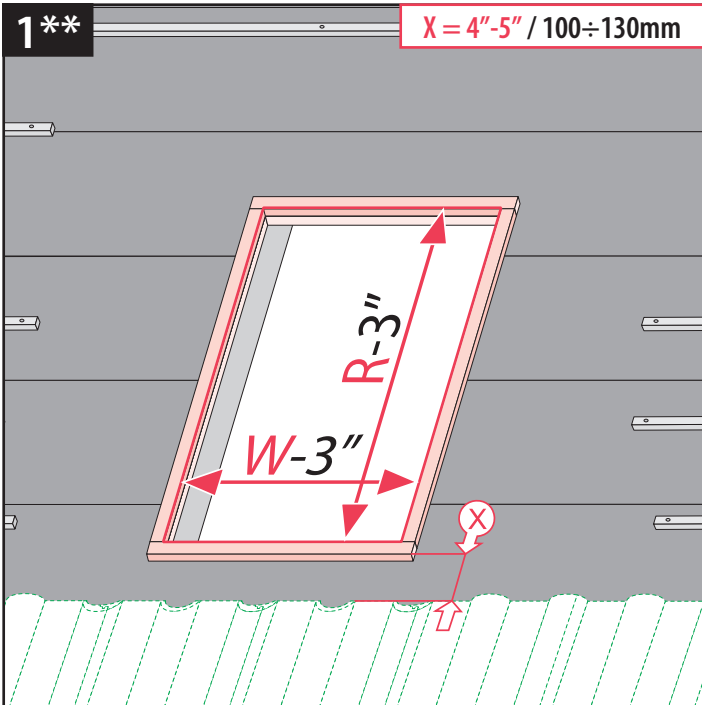

US Prepare the rough opening in the roof in the dimensions of W-3" i R-3" (dimensions W and R are given in a table on page 2). Place wooden battens around the opening. Battens should be of the same thickness as battens used for roofing material.
Top parts of tiles or profiled metal sheets, must be prepared as shown in the flashing installation instruction. Temporary remove the battens around the rough opening. Keep the distance between the rough opening and the top edge of the roofing material.

FR Ménagez dans le toit une ouverture brute de 75 mm (3 po) de largeur (W) sur 75 mm (3 po) de hauteur (R) (voir la largeur W et la hauteur R dans un tableau à la page 2). Placez des liteaux de bois tout autour. Les liteaux doivent être de la même épaisseur que les liteaux utilisés pour le matériau de toiture.
Il faut préparer le dessus des tuiles ou des tôles profilées comme indiqué dans les instructions d'installation du solin. Retirez temporairement les liteaux autour de l'ouverture brute. Maintenez la distance entre cette dernière et la bordure supérieure du matériau de toiture.

ES Prepare the abertura áspera en el techo con las dimensiones de W-3" i R-3" (las dimensiones W y R se indican en una tabla en la página 2). Coloque los listones de madera alrededor de la abertura. Los listones deben ser del mismo grosor que los utilizados para material de techado.
Las partes superiores de las baldosas o chapas metálicas perfiladas, deben prepararse como se muestra en la instrucción de instalación parpadeante. Retire temporalmente los listones alrededor de la abertura rugosa. Mantenga distancia entre la abertura áspera y el borde superior del material de la cubierta.

KR 지붕의 대략적인 개구부를 W-3" i R-3"치수로 준비합니다. (치수 W 및 R은 2 페이지의 표에 나와 있습니다). 개구부 주변에 나무 판을 놓으십시오. 판재는 지붕재료에 사용되는 판재와 같은 두께이어야 합니다. 타일 또는 프로파일링된 금속시트의 상단부분은 후레칭 설치 지침에 표시된대로 준비해야 합니다. 대략적인 개구부 주변의 판금을 임시로 제거하십시오. 대략적인 개구부와 지붕재의 상단 가장자리 사이의 거리를 유지하십시오.

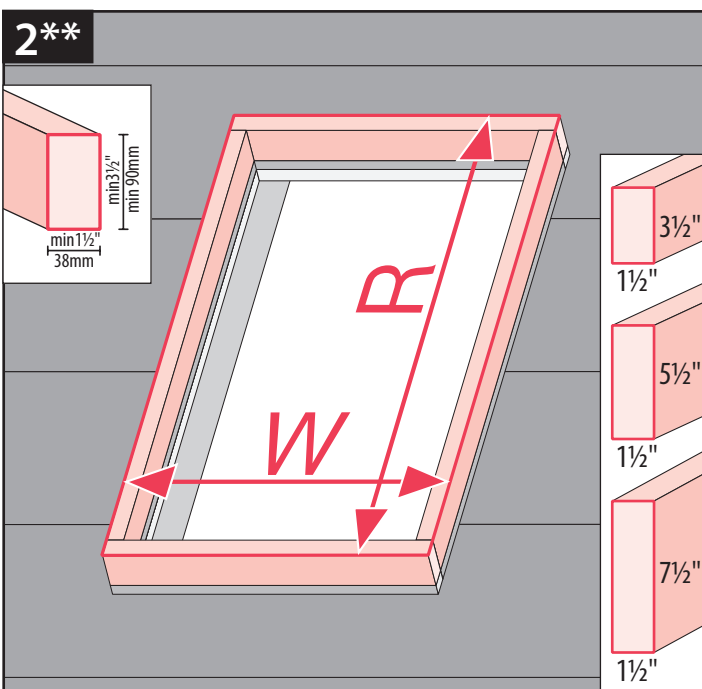

US Build a curb around the rough opening using a standard 2x4, 2x6 or 2x8 lumber.
FR Construisez une bordure de 2 x 4, 2 x 6 ou 2 x 8 autour de l'ouverture brute.
ES Construya un bordillo de 2x4, 2x6 o 2x8 alrededor de la abertura áspera.
KR 대략적인 개구부 주위에 커브 크기 2x4, 2x6 또는 2x8을 제작하십시오.

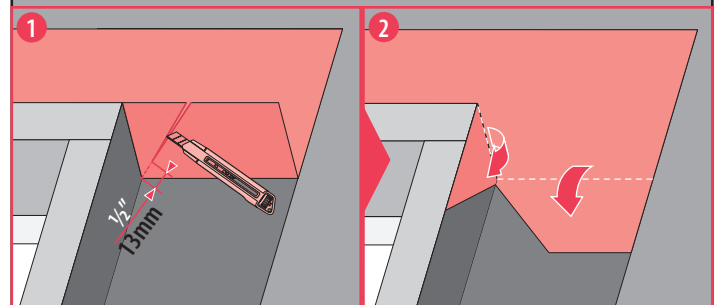
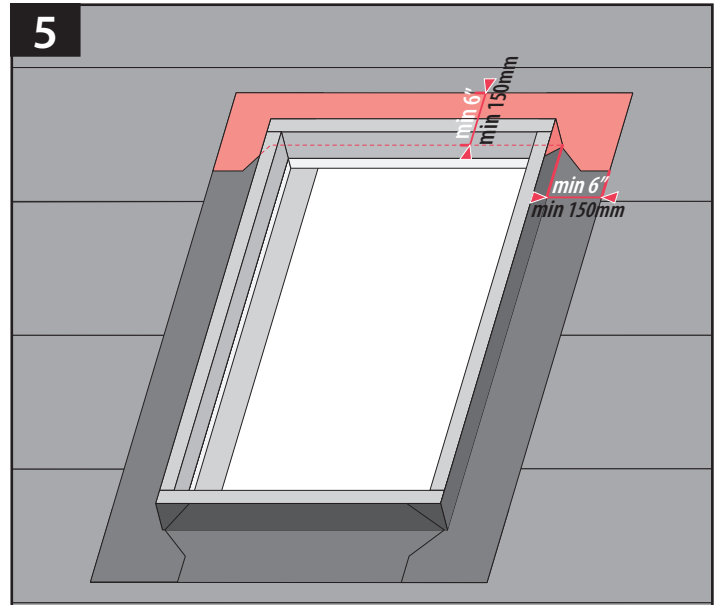

US Apply self-adhesive underlayment on the top part of the curb.
FR Appliquez la couche adhésive de la base sur la partie supérieure du rehaussement.
ES Aplique el autoadhesivo en la parte superior del borde.
KR 자착식 하지재를 그림과 같이 목재를 상단에 부착하십시오.

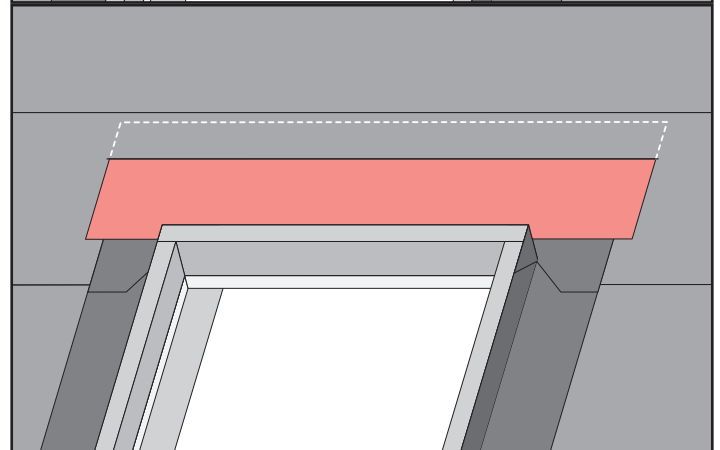
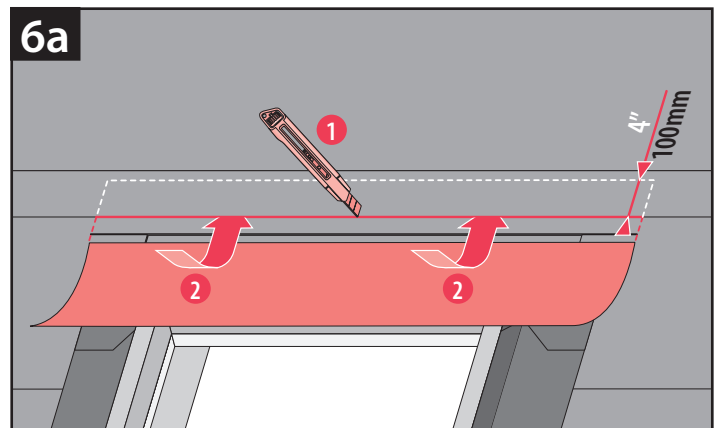

US To ensure proper water drainage, interweave the skylight's underlayment with the existing roof underlayment (retrofit).
FR Afin d'assurer l'évacuation de l'eau, sous la couche existante introduisez la couche supplémentaire de la base (modernisation).
ES Para asegurar el adecuado drenaje de agua, agregue una capa adicional de impermeabilizante debajo de la capa subyacente (modernización).
KR 적절한 배수를 위해 채광창의 하지재를 기존에 설치된 하지재와 함께 부착하십시오.(개량).

6b

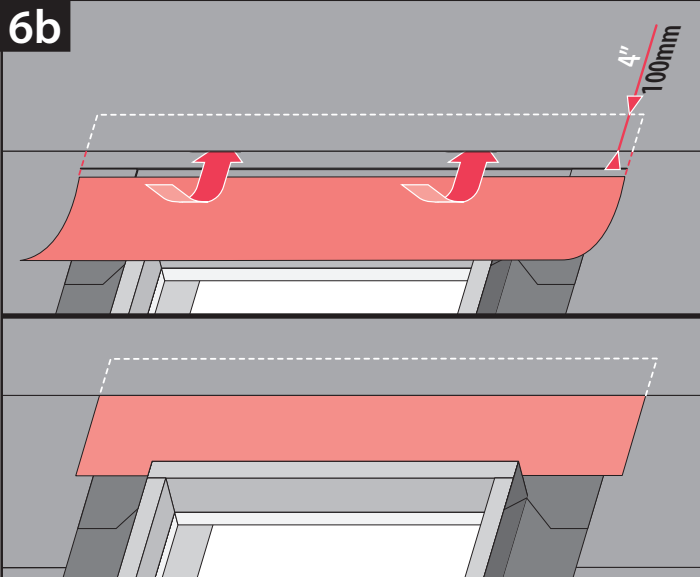

US	To ensure proper water drainage, interweave the skylight's underlayment with the existing roof underlayment (new construction).
FR	Afin d'assurer l'évacuation de l'eau, sous la couche existante introduisez la couche supplémentaire de la base (nouvelle construction).
ES	Para asegurar el adecuado drenaje de agua, agregue una capa adicional de impermeabilizante debajo de la capa subyacente (nueva construcción)
KR	적절한 배수를 위해 채광창의 하지재를 기존에 설치된 하지재와 함께 부착하십시오.(겹침길이 100mm 이상)(신규 공법).

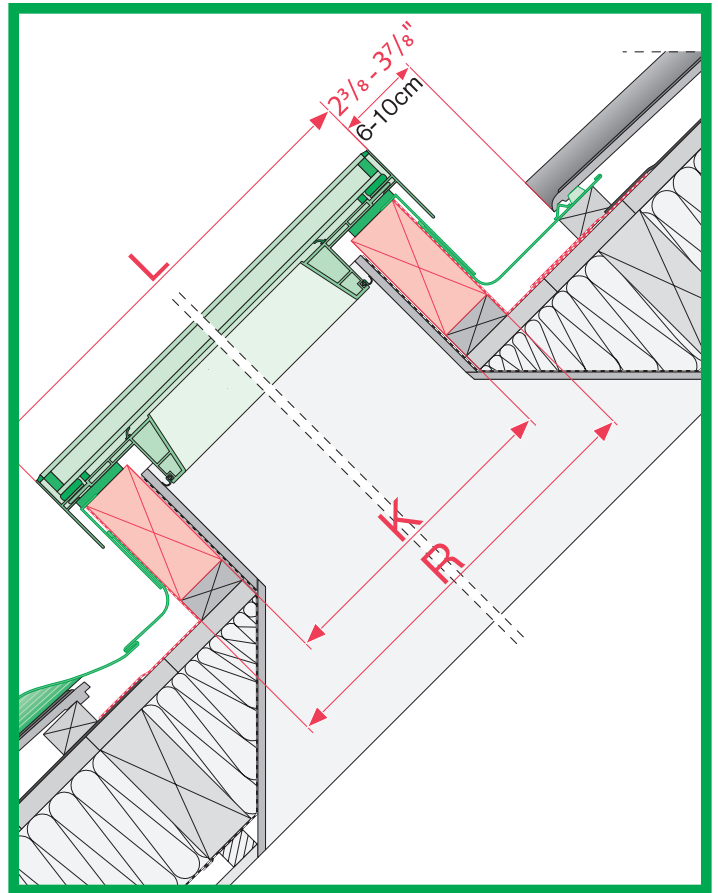
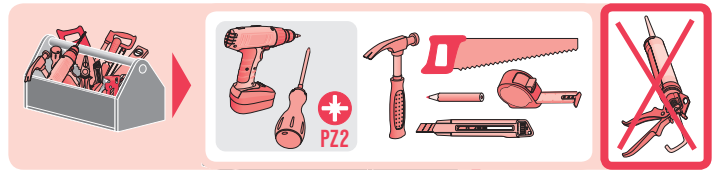

7a

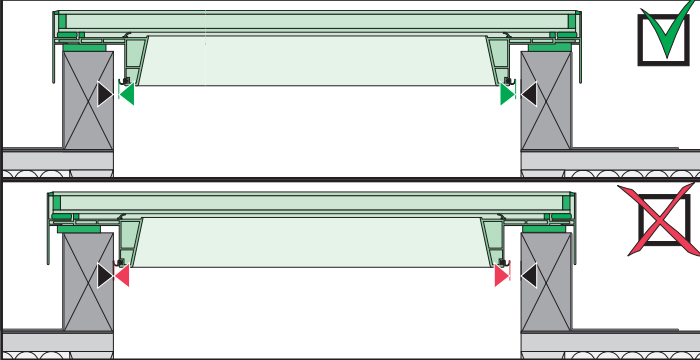
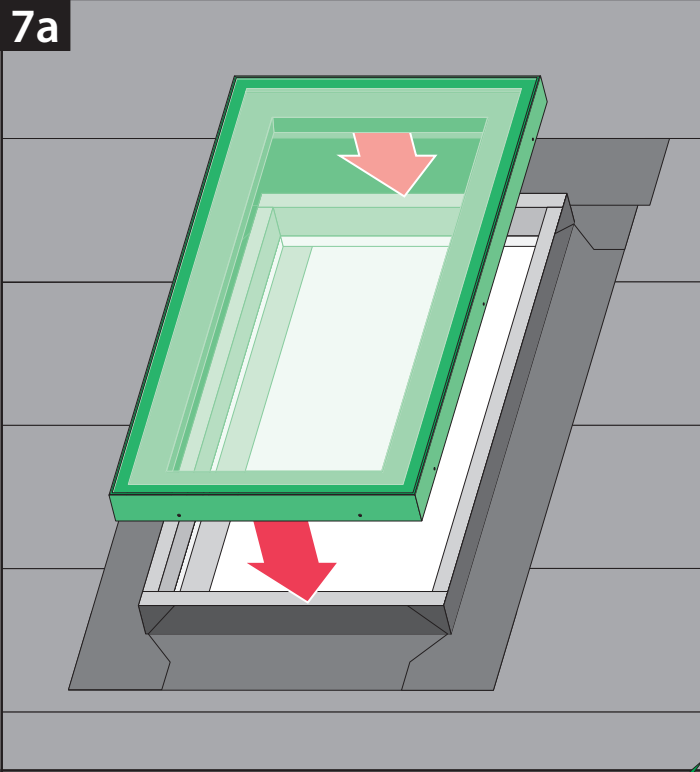

US	Place the FXC skylight over the curb. Watch and make sure the gaps between the inside of the curb and the skylights frame are equal.
FR	Installez "skylight" sur le rehaussement. Respectez les distances égales identiques entre la dimension intérieure du rehaussement et un dormant du skylight.
ES	Acomode el tragaluz FXC sobre el borde. Observe y asegúrese de que los espacios entre el interior del borde y el marco del tragaluz son iguales.
KR	FXC 채광창을 채광창과 목재를 사이의 공간이 동일하도록 사진을 참조하여 목재를 위에 설치하십시오.

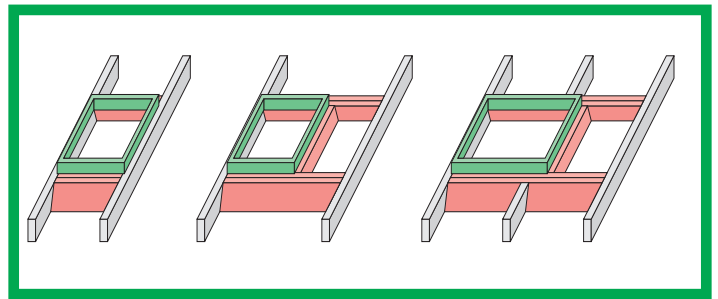
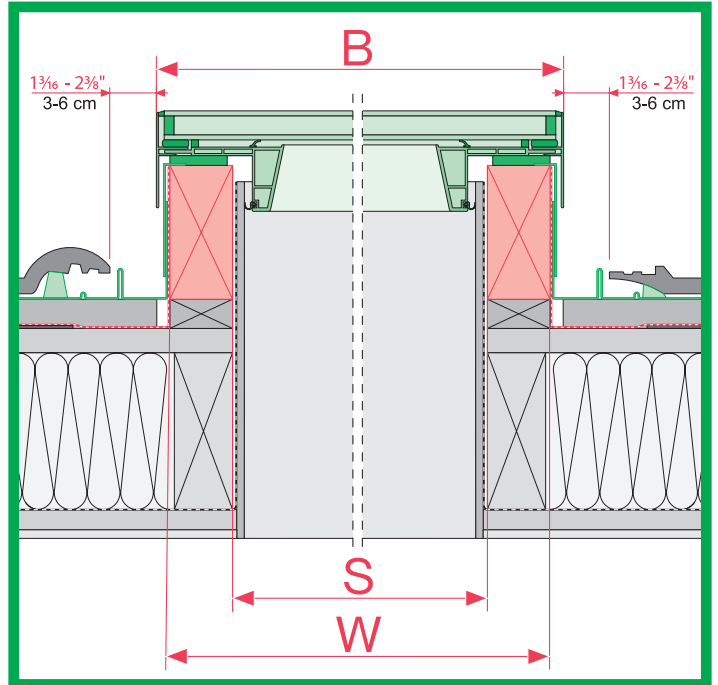

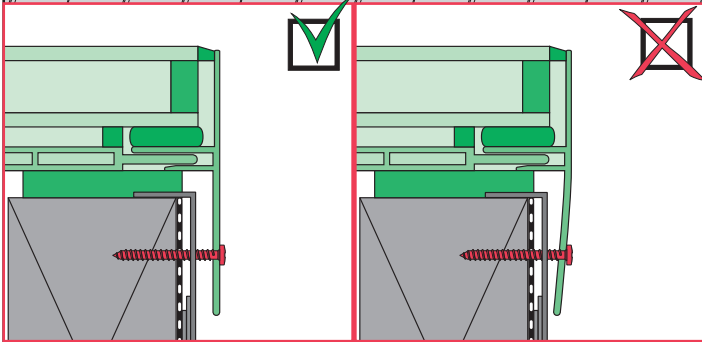
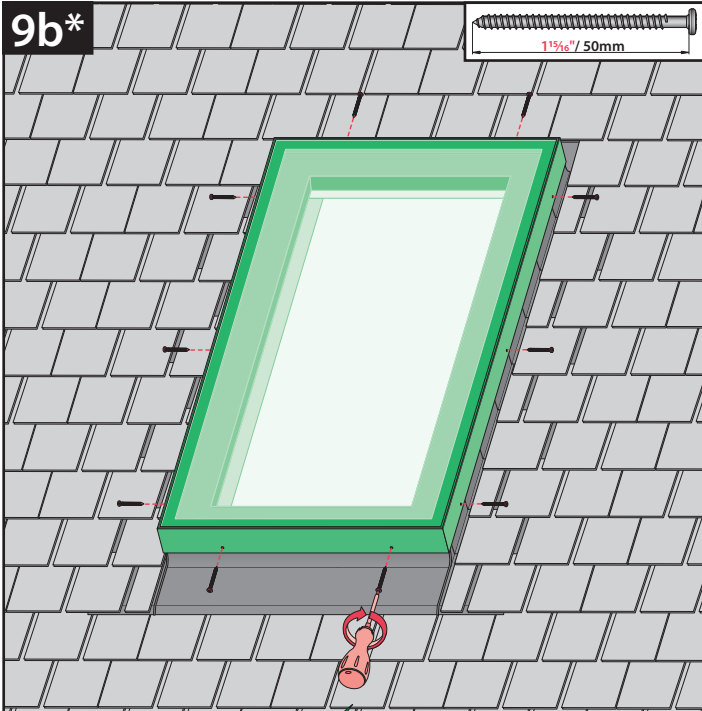

US	Secure the skylight with the screws to the curb. Skylights profile can not deform during tightening the screws.
FR	Attachez le skylight à l'aide de vis de fixation. Le profilé du skylight FXC ne doit pas se déformer pendant la fixation des vis.
ES	Asegure el tragaluz al borde con los tornillos. El perfil del tragaluz FXC no se puede deformar al atornillar.
KR	목재틀에 채광창을 나사로 고정하십시오. 나사를 조일 때, 채광창의 프로파일이 변형되어선 안됩니다.

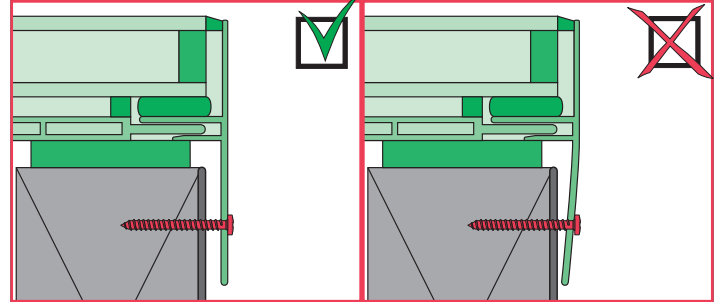
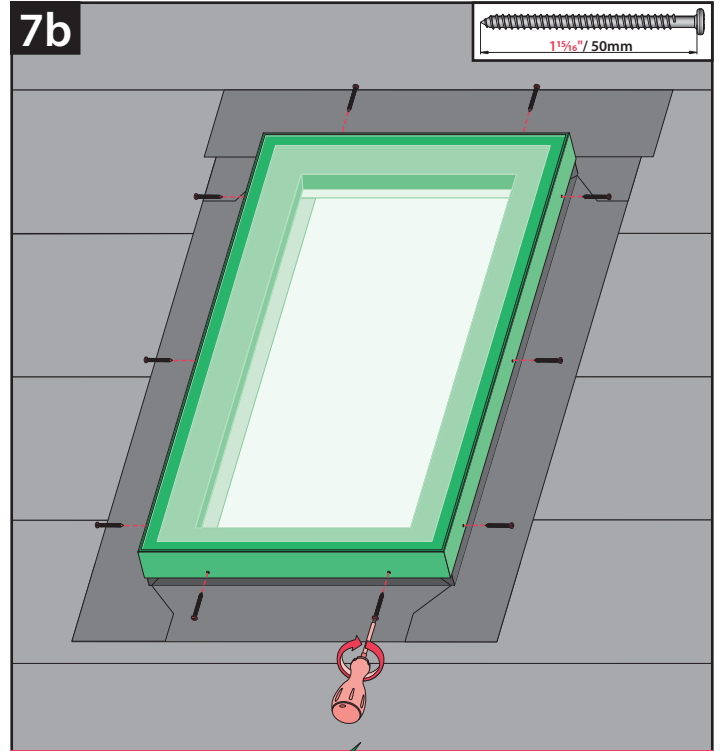

US	Secure the skylight with the screws to the curb. Skylights profile can not deform during tightening the screws.
FR	Attachez le skylight à l'aide de vis de fixation. Le profilé du skylight FXC ne doit pas se déformer pendant la fixation des vis.
ES	Asegure el tragaluz al borde con los tornillos. El perfil del tragaluz FXC no se puede deformar al atornillar.
KR	목재틀에 채광창을 나사로 고정하십시오. 나사를 조일 때, 채광창의 프로파일이 변형되어선 안됩니다.

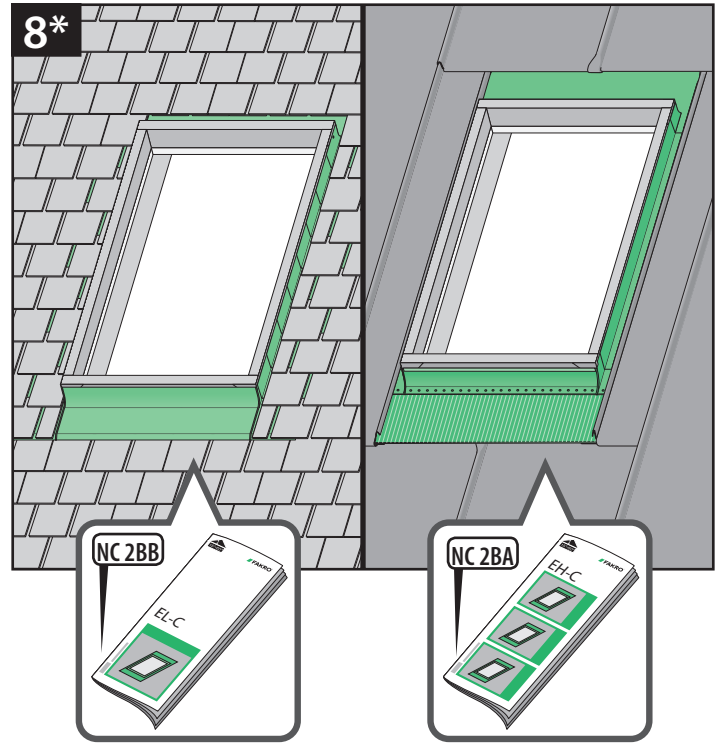
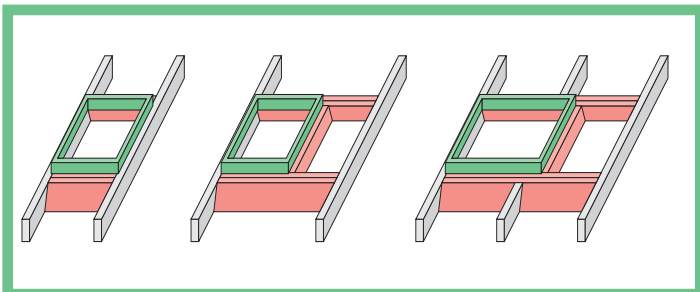
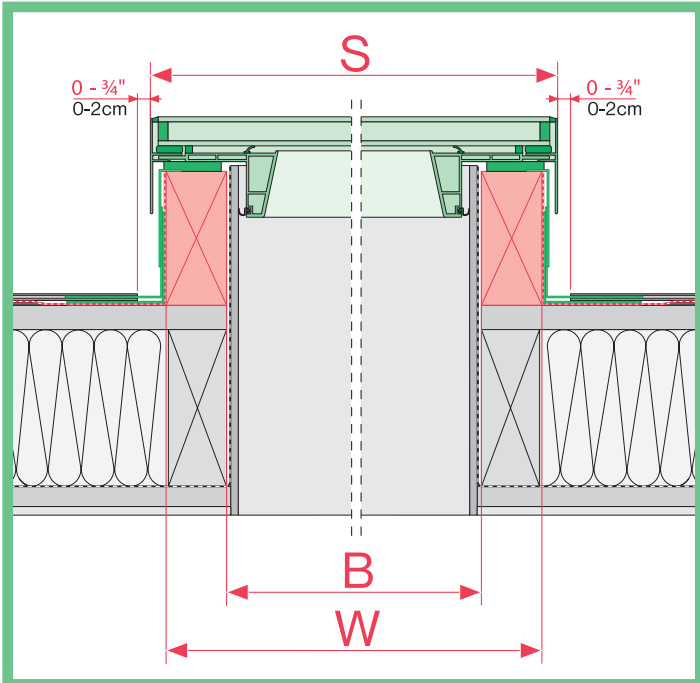
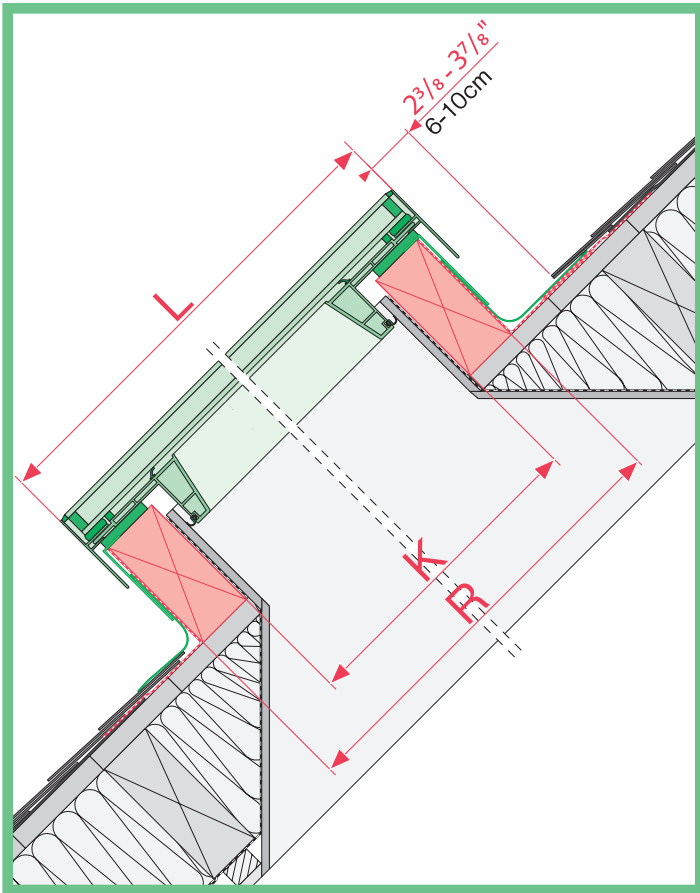
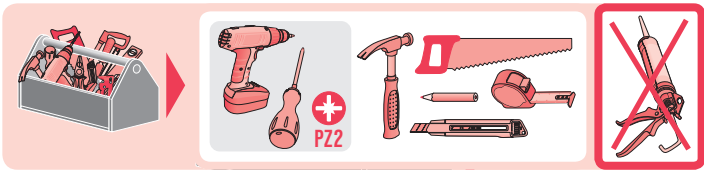

US	Install the EL-C flashing for flat roofing materials, or flashing for high profiled materials EH-C. Installation instructions for flashings come with the flashings.
FR	Installez le solin EL-C pour matériaux de toiture plats ou le solin pour matériaux à profil haut EH-C. Les instructions d'installation des solins sont livrées avec les solins.
ES	Instale el tapajuntas EL-C para materiales de techo planos, o el tapajuntas EH-C para materiales de alto perfil. Las instrucciones de instalación para el tapajuntas vienen con ellos.
KR	평평한 지붕재를 위해 EL-C 후레싱을 설치, 높은 프로파일 재료위해 EH-C 후레싱을 설치하십시오. 후레싱에 대한 설치지침은 후레싱과 함께 제공됩니다.

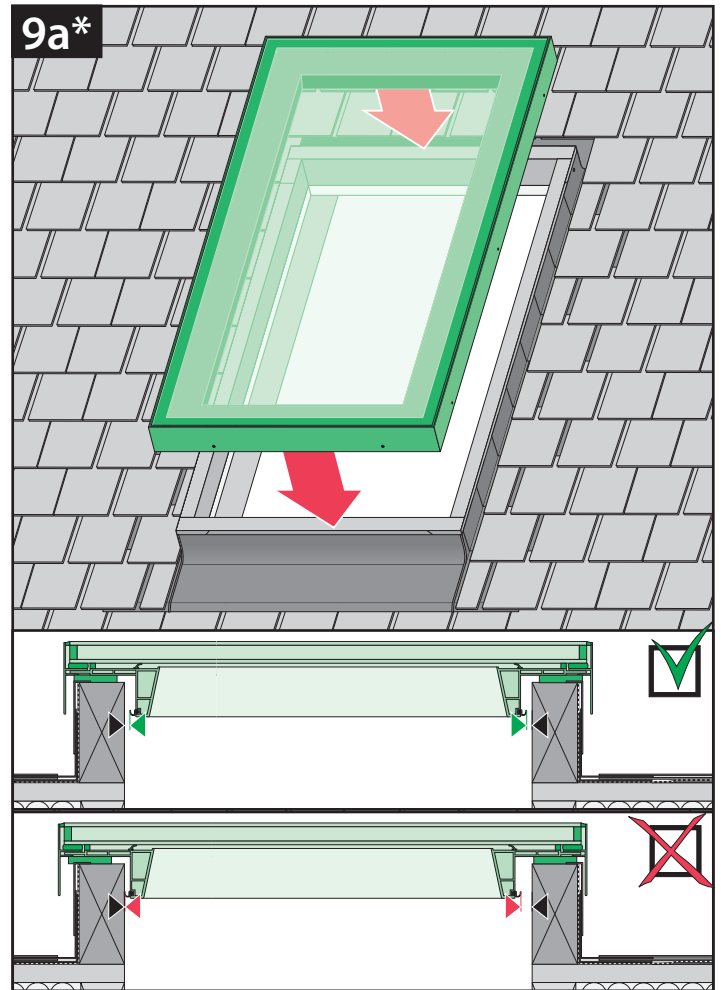

US	Place the FXC skylight over the curb. Watch and make sure the gaps between the inside of the curb and the skylights frame are equal.
FR	Placez la fenêtre de toit FXC par-dessus la bordure. Vérifiez bien que les espaces entre l'intérieur de la bordure et le cadre de la fenêtre de toit sont égaux.
ES	Coloque el tragaluz FXC sobre la acera. Observe y asegúrese de que los espacios entre el interior de la acera y el marco de tragaluz son iguales.
KR	커브 위에 FXC 천창을 놓습니다. 커브 내부와 천창사이의 간격이 동일인지 확인하십시오.

7a*

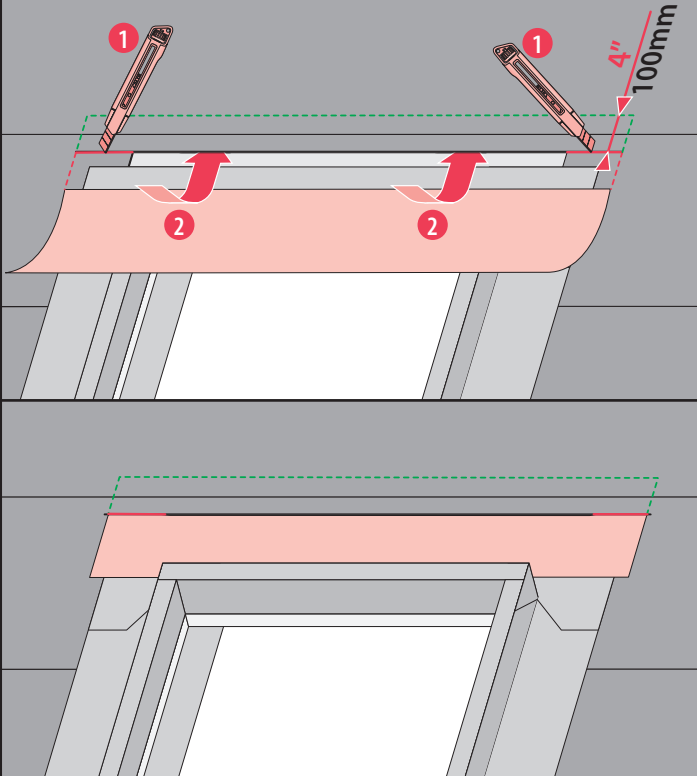

US	To ensure proper water drainage, interweave the skylight's underlayment with the existing roof underlayment (retrofit).
FR	Pour assurer le drainage adéquat de l'eau, entrelacez la sous-couche de la fenêtre de toit avec la sous-couche existante du toit (rénovation).
ES	Para garantizar un drenaje adecuado del agua, entrelace la capa inferior del tragaluz con la capa de techo existente.
KR	적절한 배수가 되게하려면 천장의 하지재를 기존지붕의 하지재에 끼워 넣습니다(새롭게 장착).

1*

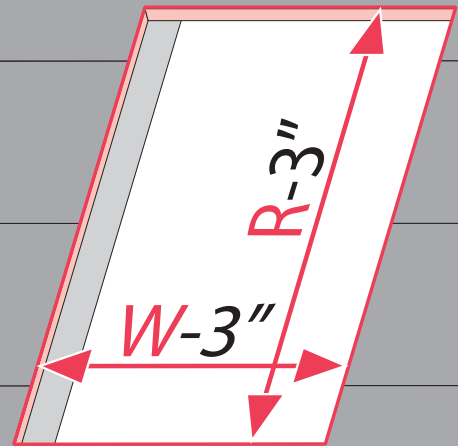

US	Prepare the rough opening in the roof in the dimensions of W-3" i R-3" (dimensions W and R are given in a table on page 2).
FR	Ménagez dans le toit une ouverture brute de 75 mm (3 po) de largeur (W) sur 75 mm (3 po) de hauteur (R) (voir la largeur W et la hauteur R dans un tableau à la page 2).
ES	Prepare la abertura áspera en el techo con las dimensiones de W-3" i R-3" (las dimensiones W y R se indican en una tabla en la página 2).
KR	지붕의 대략적인 개구부를 W-3" i R-3"치수로 준비합니다 (치수 W 및 R은 2 페이지의 표에 나와 있습니다).

7b*

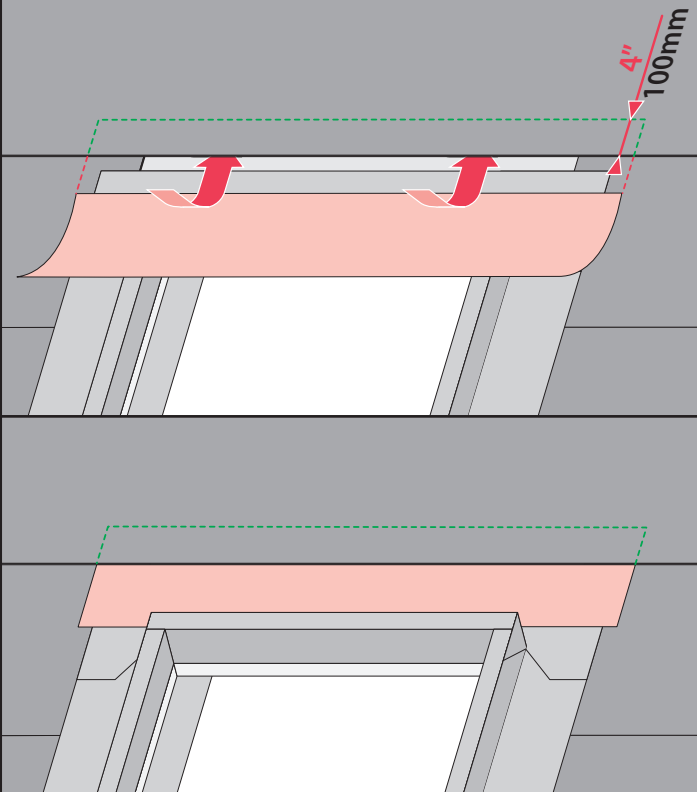

US	To ensure proper water drainage, interweave the skylight's underlayment with the new roof underlayment (new construction).
FR	Pour assurer le drainage adéquat de l'eau, entrelacez la sous-couche de la fenêtre de toit avec la sous-couche neuve (nouvelle construction).
ES	Para garantizar un drenaje adecuado del agua, entrelace la capa inferior del tragaluz con la nueva capa de techo.
KR	적절한 배수가 되게하려면 천장의 하지재를 새로운 지붕하지재에 끼워 넣습니다(새로운 시공).

2*

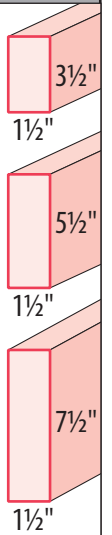
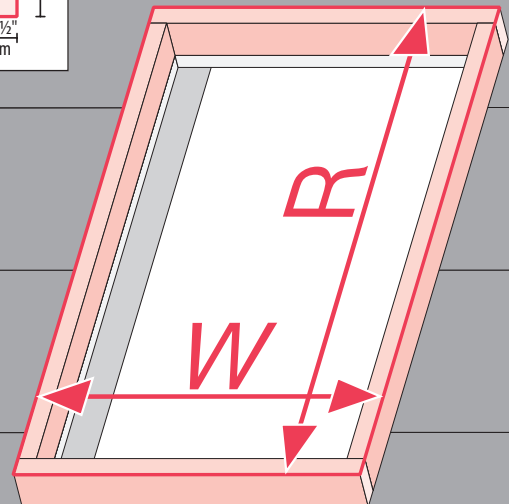
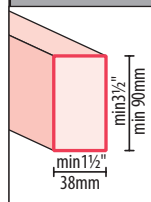

US	Build a curb size 2x4, 2x6 or 2x8 around the rough opening.
FR	Construisez une bordure de autour de l'ouverture brute.
ES	Construya un bordillo de 2x4, 2x6 o 2x8 alrededor de la abertura áspera.
KR	대략적인 개구부 주위의 커브 크기를 2x4, 2x6 또는 2x8로 제작하십시오.

3*

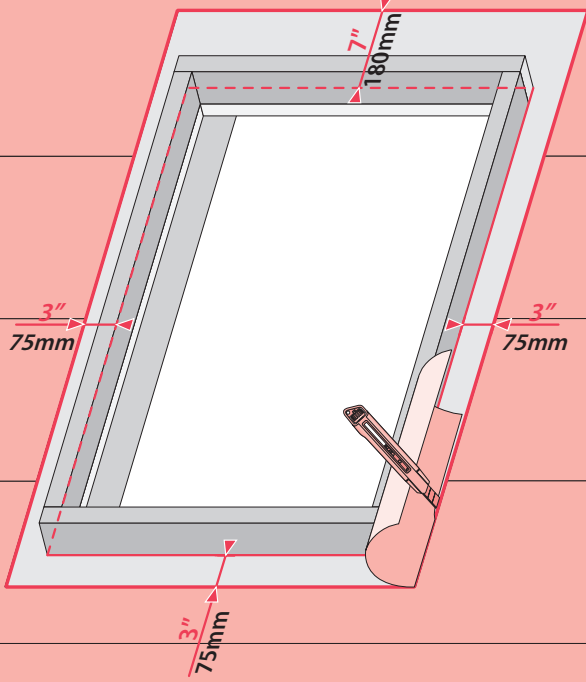

- US Remove existing roofing underlayment around the opening.
- FR Enlevez la sous-couche de toiture existante autour de l'ouverture.
- ES Retire la capa de techo existente alrededor de la abertura.
- KR 개구부 주변의 기존의 지붕 하지재를 제거하십시오.

4*

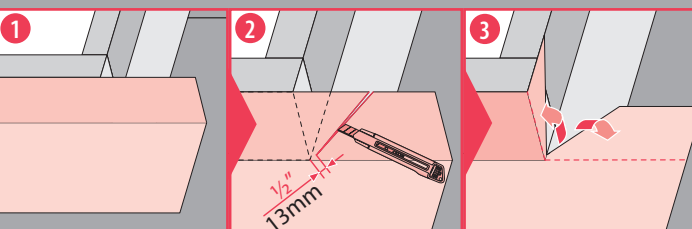
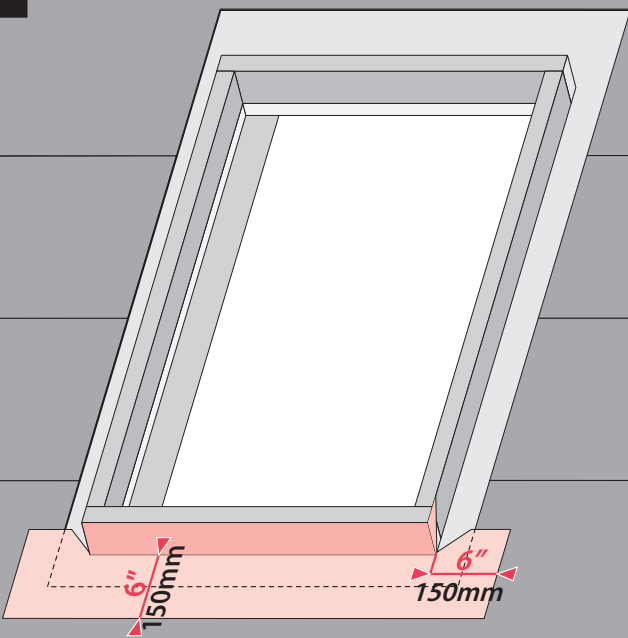

- US For complete waterproofing, apply self-adhesive underlayment at the bottom of the curb.
- FR Pour obtenir une hydrofugation complète, appliquez une sous-couche autocollante en bas de la bordure.
- ES Para una impermeabilización completa, aplique un adhesivo en la parte inferior de la acera.
- KR 완벽한 방수 처리를 하려면 커브 아래에 자체 접착성 하지재를 붙이세요.

5*

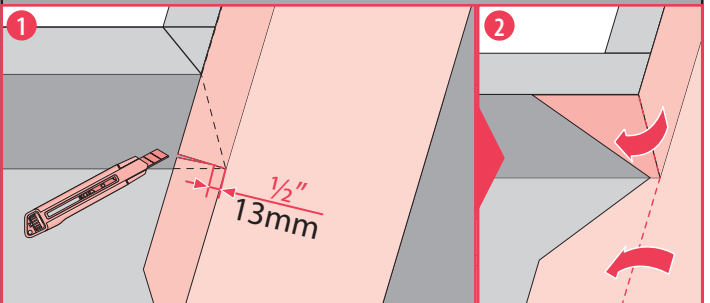
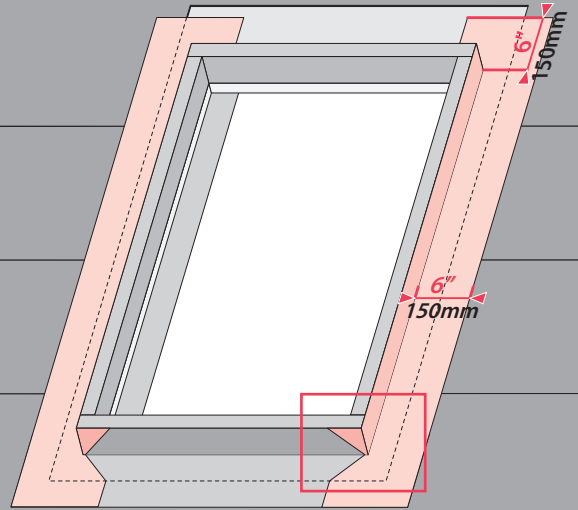

- US Apply self-adhesive underlayment on the sides of the curb.
- FR Appliquez une sous-couche autocollante sur les côtés de la bordure.
- ES Aplique una capa autoadhesiva en la parte superior de la acera.
- KR 커브 측면에 자체 접착성 하지재를 붙이세요.

6*

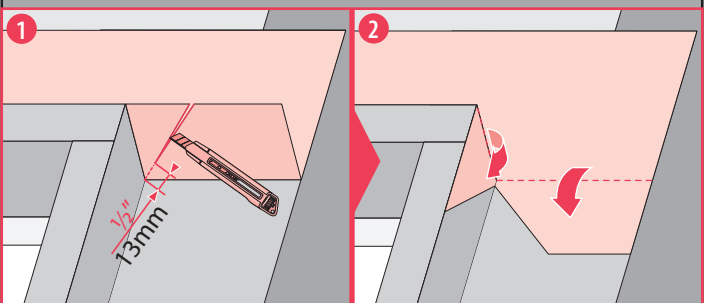
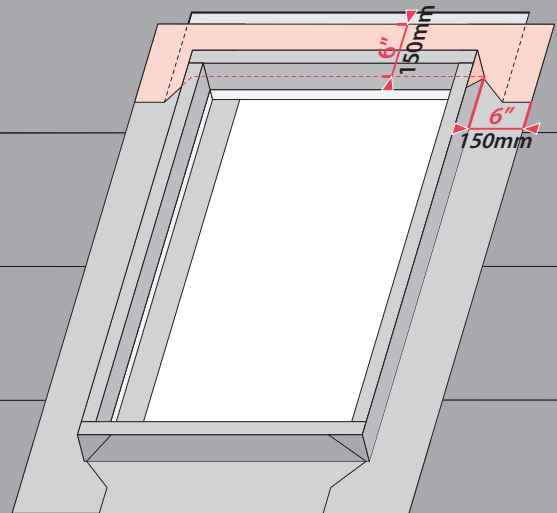

- US Apply self-adhesive underlayment on the top part of the curb.
- FR Appliquez une sous-couche autocollante sur la partie supérieure de la bordure.
- ES Aplique una capa autoadhesiva en la parte superior de la acera.
- KR 커브 윗부분에 자체 접착성 하지재를 붙이세요.