

Deck Mounted Fixed Skylight PDX INSTALLATION INSTRUCTIONS

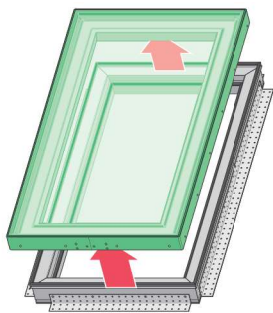

US	Preparing for the installation. See page 6.
FR	Préparation pour installation. Voir la page 6.
ES	Preparando para la instalación. Ver página 6.
KR	설치를 준비합니다. 페이지 참조 6.

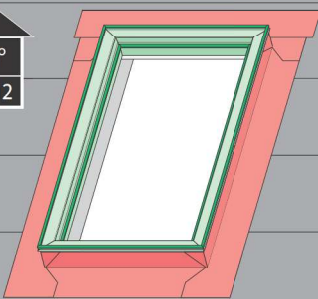
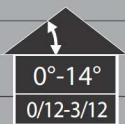

US	PDX installation on a flat roof 0°-14°. See page 7-11.
FR	PDX installation sur toit plat 0°-14°. Voir la page 7-11.
ES	Instalación de PDX en losa plana de 0-14 grados de inclinación. Ver página 7-11.
KR	0°-14° 사이의 평지붕에서의 PDX 설치. 페이지 참조 7-11.

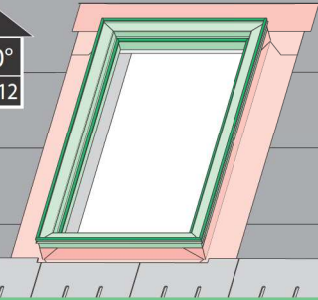

US	PDX installation on pitched roof with shingles. See page 12-17.
FR	Installation du modèle PDX sur un toit en contreplaqué avec matériau de toiture plat. Voir la page 12-17.
ES	Instalación en un techo de madera triplay con material de techo plano. Ver página 12-17.
KR	평평한 지붕재가 있는 합판 지붕에 PDX를 설치. 페이지 참조 12-17

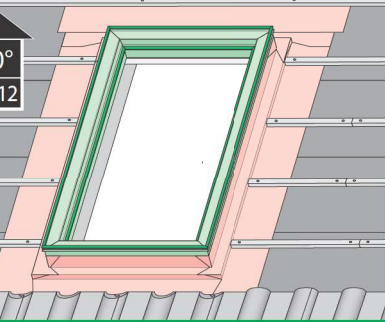

US	PDX installation on pitched roof with profiled roofing material. See page 18-24
FR	Installation du modèle PDX sur un toit avec matériau de toiture profilé. Voir la page 18-24.
ES	Instalación en un techo con material de techo perfilado. Ver página 18-24.
KR	프로파일 지붕 재료가있는 지붕에 PDX를 설치. 페이지 참조 18-24.

Confirm your rough opening.

SKYLIGHT SIZE	S [in]	L [in]	p [in]	q [in]	W [in]	R [in]
14½x45¾	20	51	13 ¼	44 ¼	14 ½	45 ¾
21x26⅞	26 ¼	32 ⅞	19 ½	25 ⅜	21	26 ⅞
21x37⅞	26 ¼	43 ⅞	19 ½	36 ⅜	21	37 ⅞
21x45¾	26 ¼	51	19 ½	44 ¼	21	45 ¾
21x54⅞	26 ¼	59 ⅞	19 ½	52 ⅞	21	54 ⅞
21x70¼	26 ¼	75 ½	19 ½	68 ¾	21	70 ¼
30⅞x37⅞	35 ¼	43 ⅞	28 ½	36 ⅜	30 ⅞	37 ⅞
30⅞x45¾	35 ¼	51	28 ½	44 ¼	30 ⅞	45 ¾
30⅞x54⅞	35 ¼	59 ⅞	28 ½	52 ⅞	30 ⅞	54 ⅞
44¼x26⅞	49 ½	32 1/8	42 ¾	25 ⅜	44 ¼	26 ⅞
44¼x45¾	49 ½	51	42 ¾	44 ¼	44 ¼	45 ¾

SKYLIGHT SIZE	S [mm]	L [mm]	p [mm]	q [mm]	W [mm]	R [mm]
14½x45¾	507	1295	336	1124	374	1162
21x26⅞	666	815	495	644	533	682
21x37⅞	666	1095	495	924	533	962
21x45¾	666	1295	495	1124	533	1162
21x54⅞	666	1515	495	1344	533	1382
21x70¼	666	1917	495	1746	533	1784
30⅞x37⅞	896	1095	725	924	763	962
30⅞x45¾	896	1295	725	1124	763	1162
30⅞x54⅞	896	1515	725	1344	763	1382
44¼x26⅞	1256	815	1085	644	1123	682
44¼x45¾	1256	1295	1085	1124	1123	1162

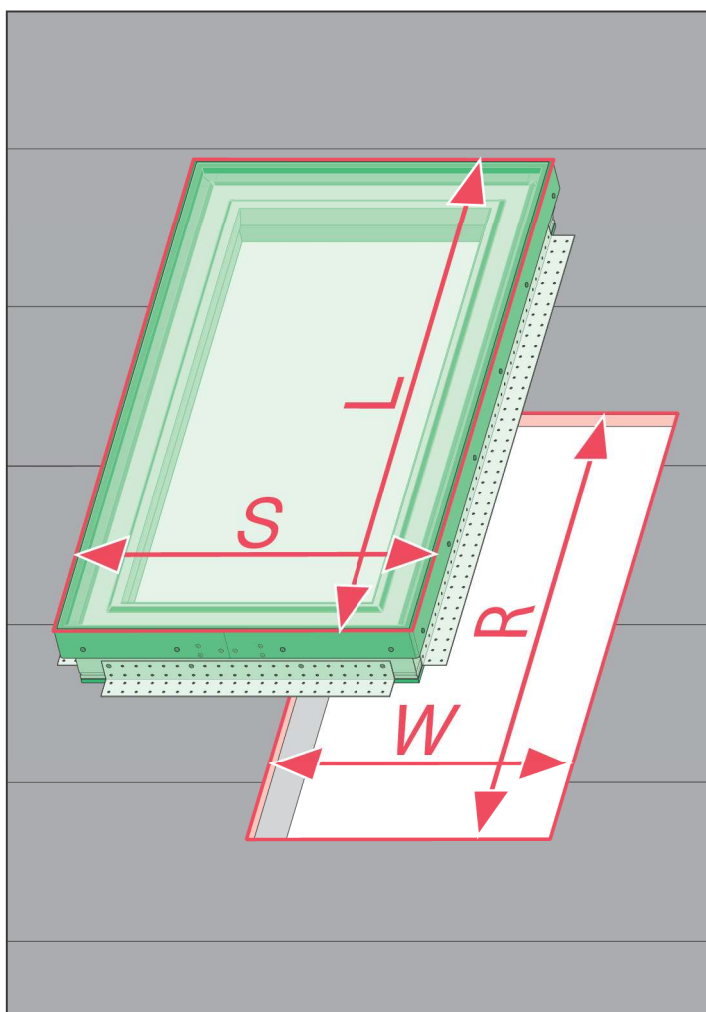

US	Installation by a professional is highly recommended Please review the instructions and carefully follow all the installation steps. Incorrect installation of the skylight will void the warranty.
FR	L'installation par un professionnel est fortement recommandée. Veuillez consulter les instructions et suivre attentivement toutes les étapes de l'installation. Une installation incorrecte du puits de lumière annulera la garantie.
ES	La instalación por un profesional es altamente recomendable. Por favor revise las instrucciones y siga cuidadosamente todos los pasos de instalación. La instalación incorrecta del tragaluz anulará la garantía.
KR	전문가에 의한 설치를 권장함. 설명서를 자세히 읽고 각 단계를 주의 깊게 실행하시오. 잘못된 천창 설치는 제품에 대한 보증을 무효 시킬 수 있습니다.



US	Do not use silicone
FR	Ne pas utiliser de silicone
ES	No utilice silicon
KR	실리콘을 사용하지 마세요

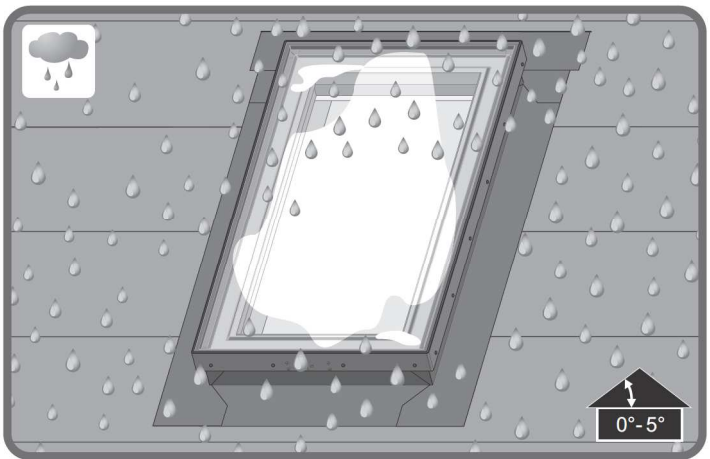

US	*Special attention guidelines for roof pitch application below 5° Below listed natural physical phenomenon are not covered under FAKRO warranty: - Dripping condensation water that forms on low sloped glass - Stains developed on a glass due to prolong contact with dirt or standing water
FR	* Directives supplémentaires concernant les installations sur une pente de toit de moins de 5 degrés. Les phénomènes naturels suivants ne sont pas couverts par la garantie de FAKRO: - l'égouttement de l'eau causée par la condensation sur le vitrage d'une fenêtre installée sur un toit à faible pente; - les taches sur le vitrage causées par la présence prolongée de saletés ou d'eau stagnante.
ES	*Lineamientos que requieren atención especial para la aplicación en tejados con pendientes menores a 5° En la lista de abajo se describen fenómenos naturales físicos que no se cubren con la garantía de FAKRO: - Gotas de agua de condensación que se forman en el vidrio con inclinación baja - Manchas en el cristal debido a el contacto prolongado con suciedad o agua estancada
KR	5도 이하의 지붕 경사면에서의 설치에 대한 특별 중요 가이드라인 아래에 기재된 자연적 현상들은 Fakro의 보증 범위에서 제외됩니다. 낮은 경사면의 유리에서 결로로 인해 떨어지는 물방울 오물과 상수에 장기간 접촉하여 창문에 생긴 얼룩.

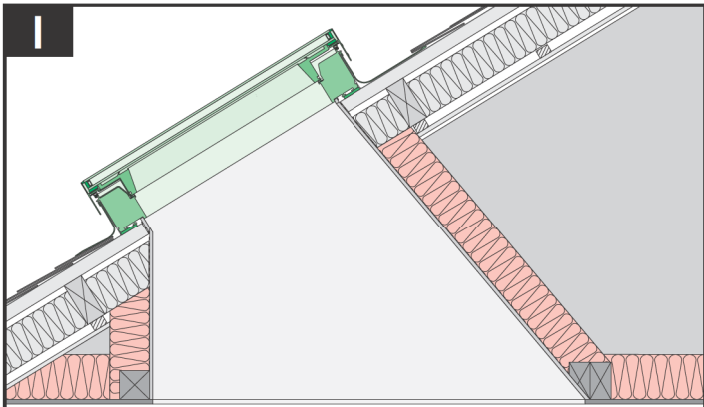

US	<p>PLANNING THE CONSTRUCTION OF A LIGHT SHAFT FOR YOUR FAKRO SKYLIGHT Building a light shaft is an integral part of finishing your FAKRO skylight installation. In the case of home with a flat ceiling it will bring the light through your attic into the room below. Construction of the shaft will govern the light distribution within the room. It is recommended to make the opening in the ceiling larger than the size of the skylight. The purpose is to create both, the visually pleasing effect of a larger room and to distribute the incoming light more widely within the room. Light shafts can also be used to direct light to work spaces such as kitchen benches or mirrored areas in bathrooms. Finishing the light shaft in pale shades or ceiling white will improve the light transmission from your skylight into the room.</p>
FR	<p>PLANIFICATION DE LA FABRICATION D'UN PUIXS DE JOUR POUR VOTRE FENÊTRE DE TOIT FAKRO La construction d'un puits de lumière fait partie intégrante de l'installation de la fenêtre de toit FAKRO. Dans le cas d'une maison avec un plafond plat, le lanterneau laisse passer la lumière du grenier dans la pièce au-dessous. La construction du puits détermine la manière dont la lumière se propage dans la pièce. Il est recommandé que l'ouverture au plafond soit plus grande que le lanterneau. L'objectif du puits est de créer l'illusion d'un espace plus grand, visuellement agréable et de diffuser la lumière entrante dans la pièce. Les puits de lumière peuvent également être utilisés pour diriger la lumière vers des espaces de travail, tels que des plans de travail dans la cuisine ou des surfaces miroir dans la salle de bain. La finition du puits dans des tons pastel ou blancs améliore la transmission de la lumière dans la pièce.</p>
ES	<p>PLANIFICANDO LA CONSTRUCCIÓN DE UN CONDUCTO DE LUZ PARA SU TRAGALUZ FAKRO La elaboración de un vano o claro de luz constituye una parte integral para terminar la instalación de un tragaluz FAKRO. En el caso de viviendas con techos planos, el tragaluz permite que la luz del ático entre en la habitación de abajo y su construcción determina la distribución de la luz dentro de la habitación. Se recomienda que la apertura del techo sea mayor que el tragaluz. El propósito del tragaluz es crear un efecto agradable de una habitación de mayor tamaño y propagar la luz que entra en la habitación. Los tragaluces también se pueden usar para dirigir la luz a los espacios de trabajo, tales como alacenas de cocina o espejos en el baño. El acabado del tragaluz en tonos pastel o blancos mejora la transmisión de la luz desde el mismo a la habitación.</p>
KR	<p>파크로 천장을 이용한 채광통로 설계 라이트 샤프트를 짓는 것은 FAKRO 채광창 설치를 끝내기 위해 필수적입니다. 평평한 천장을 가진 집의 경우, 다락방을 통해 아래의 방으로 빛을 가져올 것입니다. 샤프트 공사는 실내 배광에 영향을 미칠 것입니다. 천장의 개구부를 채광창의 크기보다 크게 만드는 것이 좋습니다. 그 목적은 큰 방의 시각적으로 쾌적한 효과를 만드는 것과 들어오는 빛을 방 안에서 더 넓게 분포하도록 하는 것입니다. 또한 라이트 샤프트는 부엌 벤치나 욕실의 반사되는 구역과 같은 작업 공간으로 빛을 향하도록 할 수 있습니다. 연한 색조의 라이트 샤프트와 흰색 천장으로 마무리하면 채광창에서 방으로 들어오는 빛 투과 효과를 향상시킬 수 있습니다.</p>

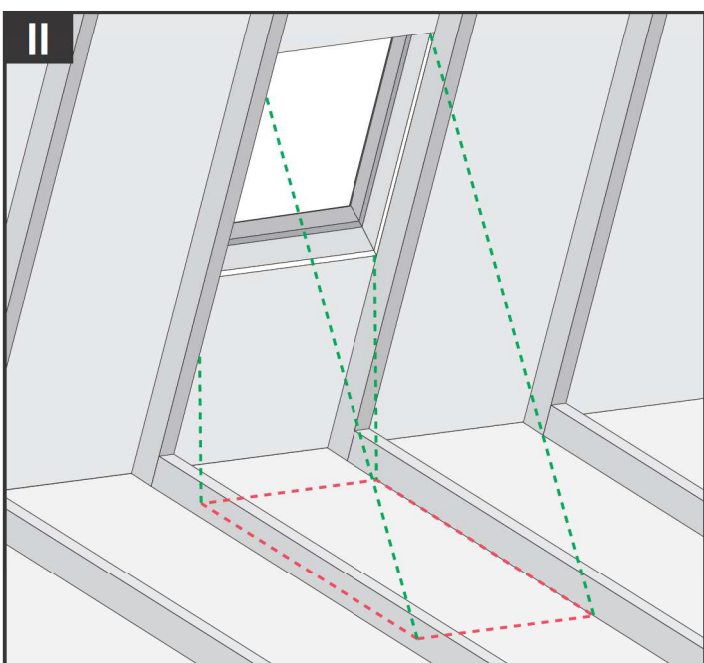

US	Decide the location and size of the light shaft relative to the skylight and the room.
FR	La première étape consiste à sélectionner l'emplacement et la taille du puits de lumière par rapport au lanterneau et à la pièce.
ES	El primer paso consiste en elegir la ubicación y el tamaño del tragaluz con respecto espacio de la habitación.
KR	채광창과 방을 기준으로 라이트 샤프트의 위치와 크기를 결정합니다.

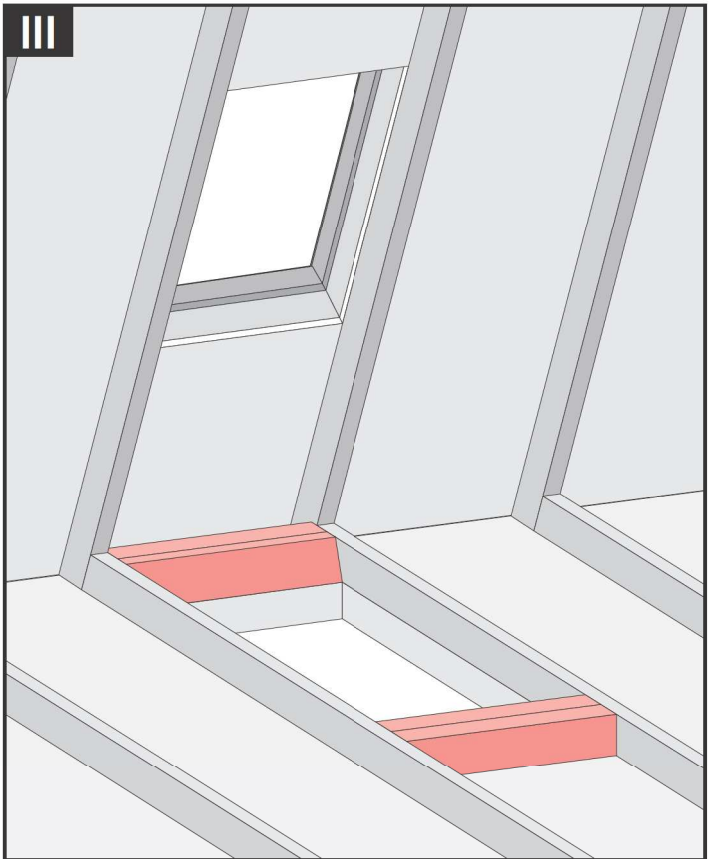

US	Prepare the hole in the ceiling using headers and trimmers. Follow the rules used in roof and wall construction.
FR	Préparer l'ouverture dans le plafond à l'aide des poutres auxiliaires et de plafond. Respecter les règles utilisées dans la construction des toits et des murs.
ES	A continuación, prepare el vano o claro en el techo con ayuda de vigas auxiliares y viguetas. Se deben respetar las normas utilizadas en la construcción de techos y paredes.
KR	헤더와 트리머를 사용하여 천장에 구멍을 만듭니다. 지붕과 벽 공사에 사용되는 규정을 따릅니다.

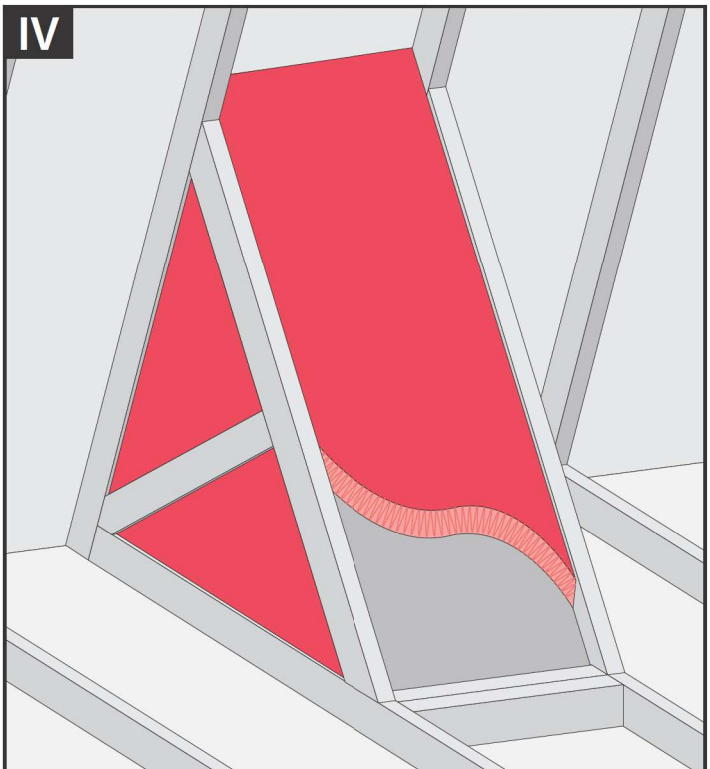

US	Frame out the shaft, line with plasterboard, and ensure that the shaft is clad with roofing insulation in the roof cavity. This will reduce heat transmission from the roof cavity into the home in the summer, and help reduce heat loss from the home in the winter.
FR	Préparez un cadre au puits, munissez-le d'une plaque de plâtre et assurez-vous que le puits est enveloppé avec l'isolation de la toiture dans la cavité du toit. En été, cela réduira la transmission de chaleur provenant de la cavité du toit vers la maison et aidera à réduire la perte de chaleur en hiver.
ES	Marque los conductos, raye con yeso y asegure que el conducto está revestido con el aislamiento del techo en la cavidad del techo. Esto reducirá la transmisión de calor de la cavidad del techo dentro de la casa en el Verano, y ayuda a reducir la pérdida de calor de la casa en el invierno.
KR	채광통로 설치를 위한 프레임 세우고 석고보드 등으로 통로 면을 만드세요. 단열재로 채광통로를 감싸세요. 단열재 시공은 여름철 천장의 열기가 실내로 유입되는 것을 줄이고, 겨울철 열 손실을 줄입니다.

US	Preparing for the installation.
FR	Préparation pour installation.
ES	Preparando para la instalación.
KR	설치를 준비합니다.

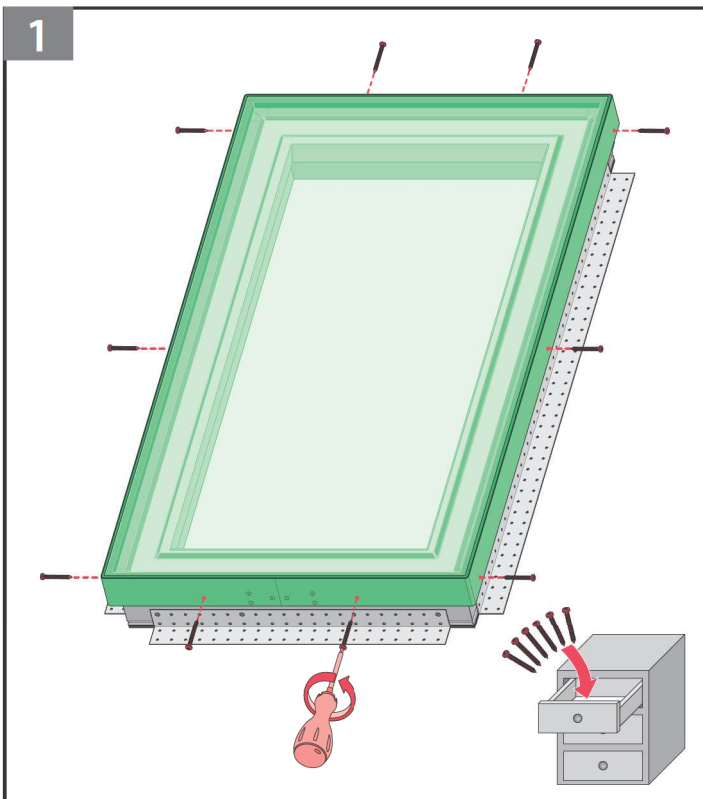

US	Remove and save all the screws fastening the skylight sash.
FR	Dévisser et garder toutes les vises qui fixent l'ouvrant de la fenêtre.
ES	Retire y guarde todos los tornillos que sujetan la hoja del tragaluz.
KR	천창 새시를 고정하는 모든 나사를 탈거하여 보관합니다.

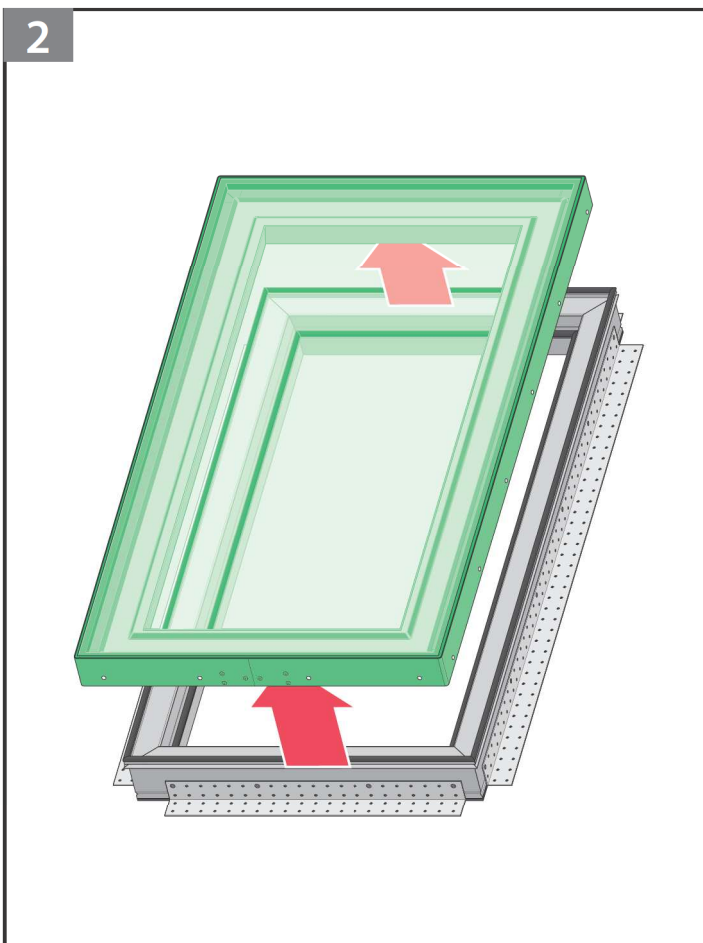

US	Remove the skylight sash from the frame.
FR	Retirer l'ouvrant de la fenêtre du dormant.
ES	Retire la hoja del tragaluz del marco.
KR	프레임에서 천창을 제거합니다.

US	PDX installation on a flat roof 0°-14°.
FR	PDX installation sur toit plat 0°-14°.
ES	Instalación de PDX en losa plana de 0-14 grados de inclinación.
KR	0°-14° 사이의 평지붕에서의 PDX 설치.

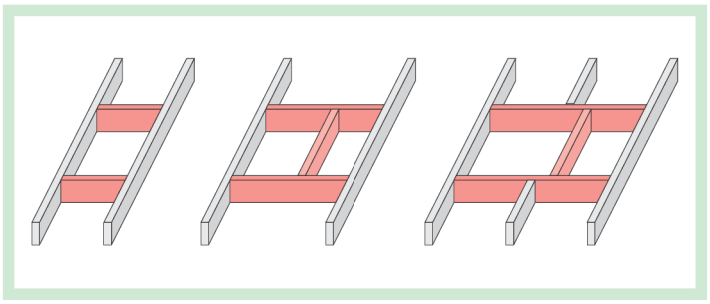
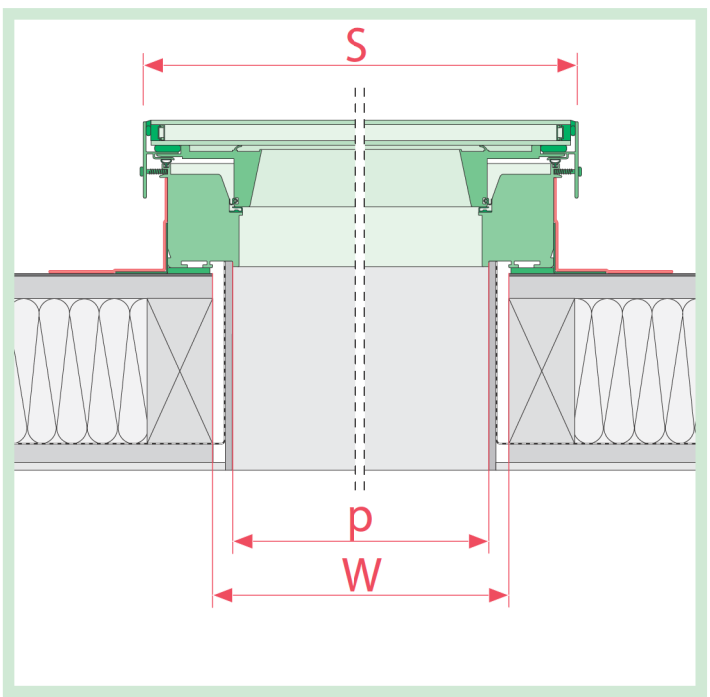
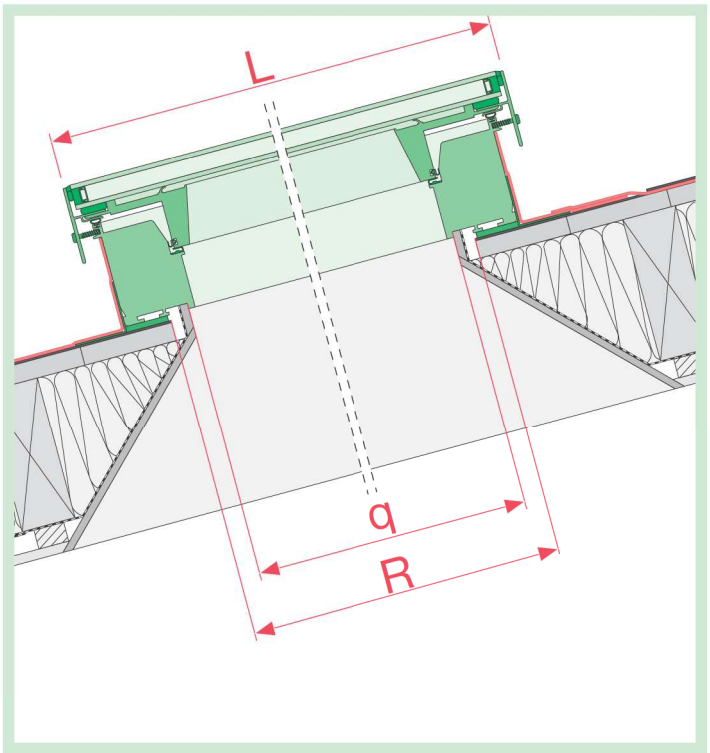
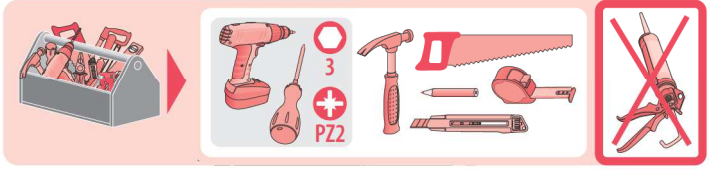

1

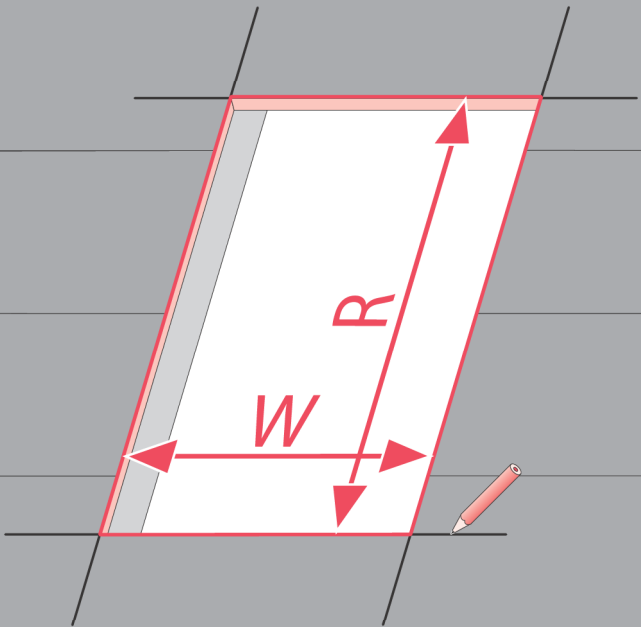

US	Mark each end of rough opening as shown above.
FR	Préparez l'ouverture de montage dans le toit conformément aux dimensions W i R (dimensions W et R sont mentionnées dans le tableau sur la page 2).
ES	Préparez l'ouverture de montage dans le toit conformément aux dimensiones W i R (dimensiones W et R sont mencionnées dans le tableau sur la page 2).
KR	지붕의 W i R 의 위치에 적절한 가로, 세로의 개구부를 준비하십시오.(W i R 의 위치에 적절한 개구부 수치는 2페이지에 표시되어 있습니다.)

2

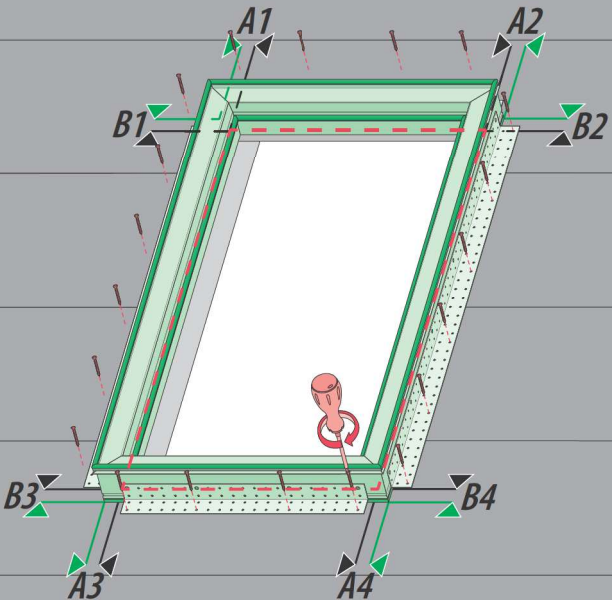
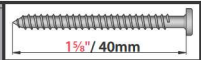

$$A1=A2=A3=A4$$

$$B1=B2=B3=B4$$

US	Place the PDX skylight over the opening. Make sure the gaps between the opening and the skylight's frame are equal.
FR	Placez la fenêtre de toit PDX au dessus de l'ouverture. Assurez-vous que les espaces entre l'ouverture et le cadre de la fenêtre sont égaux.
ES	Coloque el tragaluz PDX (ventana) sobre la abertura. Observe y asegúrese de que los espacios entre la abertura y el marco de la claraboya sean iguales.
KR	개구부 위에 PDX 스카이라이트를 놓습니다. 개구부 사이의 틈새를 관찰하고 확인합니다. 그리고 천창의 프레임은 동일합니다.

3

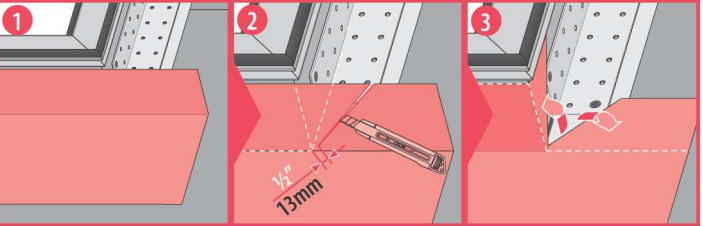
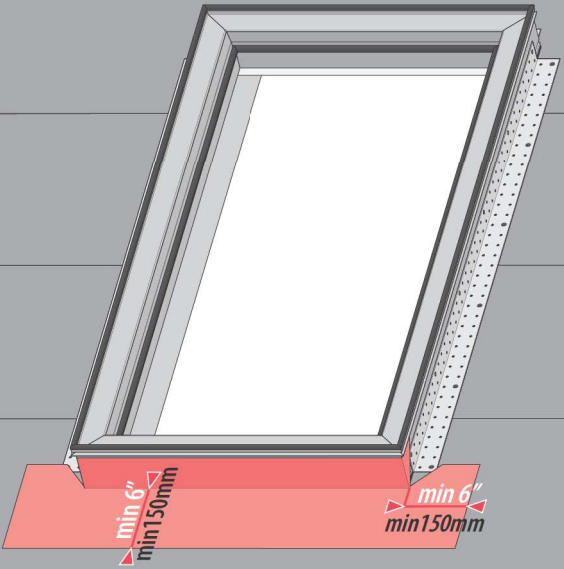

US	For complete waterproofing, apply self-adhesive underlayment (separate purchase) starting at the bottom of the skylight.
FR	Pour une étanchéité totale, utiliser le bande d'étanchéité repliable en partie basse (vendu séparément).
ES	Para una impermeabilización completa, aplique un sellador autoadhesivo para techo (se compra por separado) comenzando en la parte inferior del tragaluz.
KR	완전방수를 위해서는 천장 밑부분부터 자가접착식 밀결개(별매)를 설치해주세요..

4

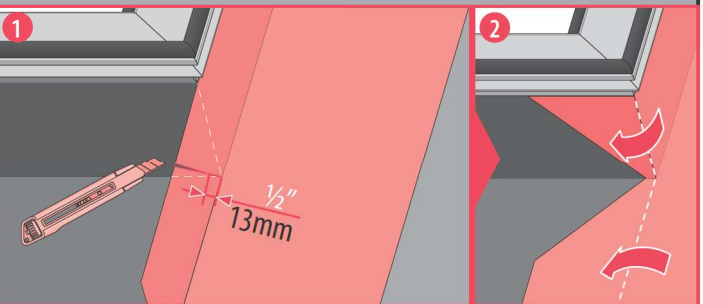
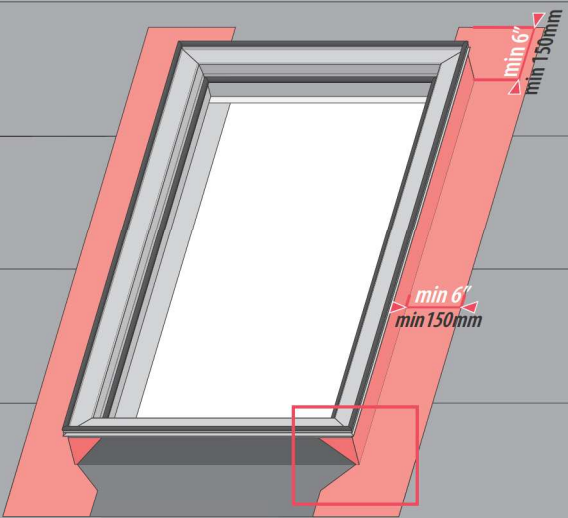

US	Apply self-adhesive underlayment on the sides of the skylight.
FR	Appliquez la couche adhésive de la base sur la partie latérale du rehaussement.
ES	Aplique el autoadhesivo en los lados del borde.
KR	자착식 하지재를 그림과 같이 순서대로 목재를 양 측면에 부착하십시오.

5

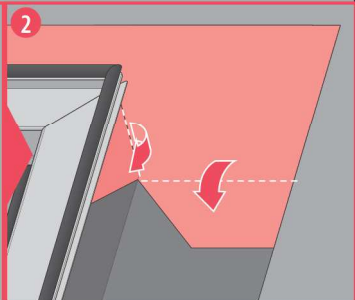
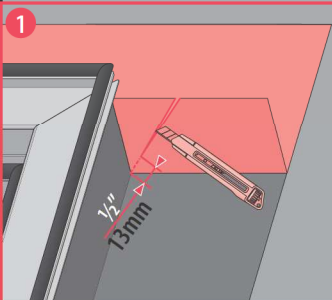
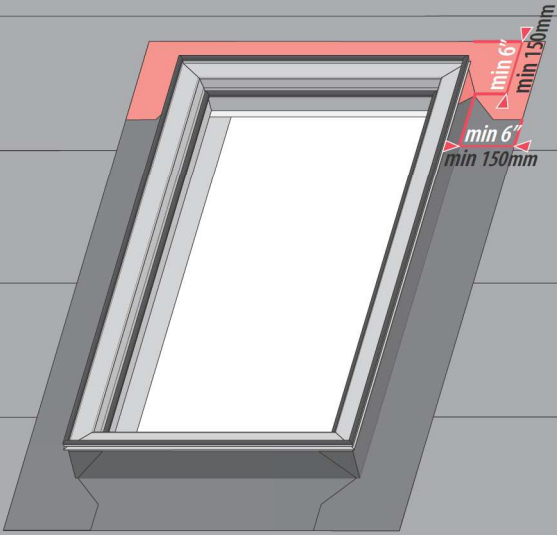

US	Apply self-adhesive underlayment on the top part of the skylight.
FR	Appliquez la couche adhésive de la base sur la partie supérieure du rehaussement.
ES	Aplique el autoadhesivo en la parte superior del borde.
KR	자척식 하지재를 그림과 같이 목재를 상단에 부착하십시오.

6a

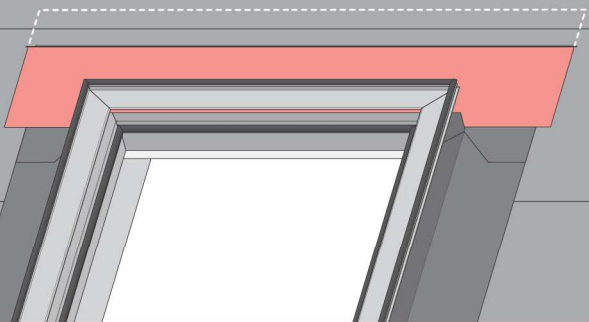
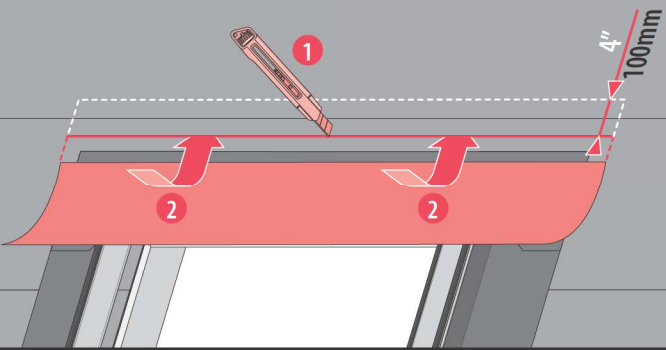

US	To ensure proper water drainage, interweave the skylight's underlayment with the existing roof underlayment (retrofit).
FR	Afin d'assurer l'évacuation de l'eau, sous la couche existante introduisez la couche supplémentaire de la base (modernisation).
ES	Para asegurar el adecuado drenaje de agua, agregue una capa adicional de impermeabilizante debajo de la capa subyacente (modernización).
KR	적절한 배수를 위해 채광창의 하지재를 기존에 설치된 하지재와 함께 부착하십시오.(개량).

6b

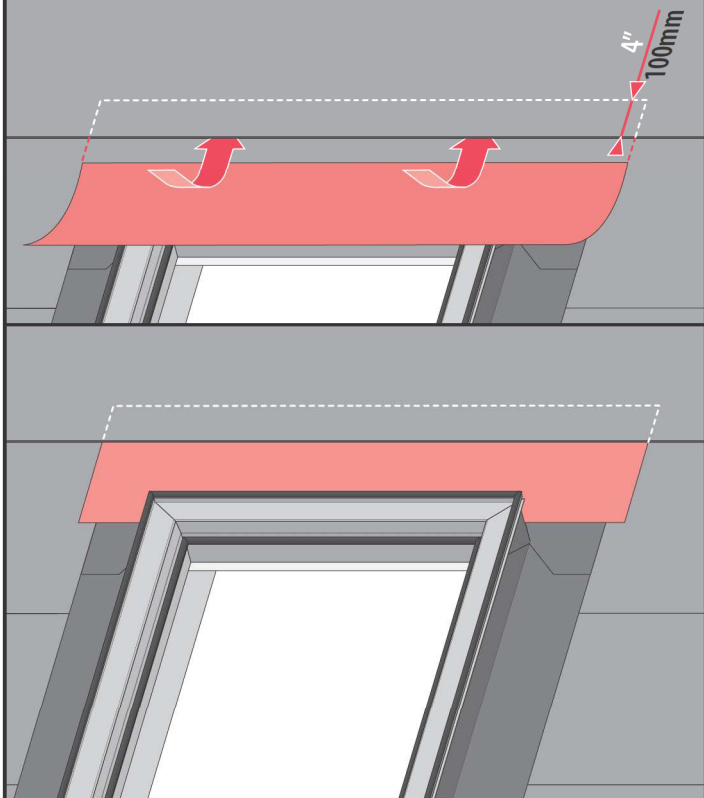

US	To ensure proper water drainage, interweave the skylight's underlayment with the existing roof underlayment (new construction).
FR	Afin d'assurer l'évacuation de l'eau, sous la couche existante introduisez la couche supplémentaire de la base (nouvelle construction).
ES	Para asegurar el adecuado drenaje de agua, agregue una capa adicional de impermeabilizante debajo de la capa subyacente (nueva construcción)
KR	적절한 배수를 위해 채광창의 하지재를 기존에 설치된 하지재와 함께 부착하십시오.(겹침길이 100mm 이상)(신규 공법).

7

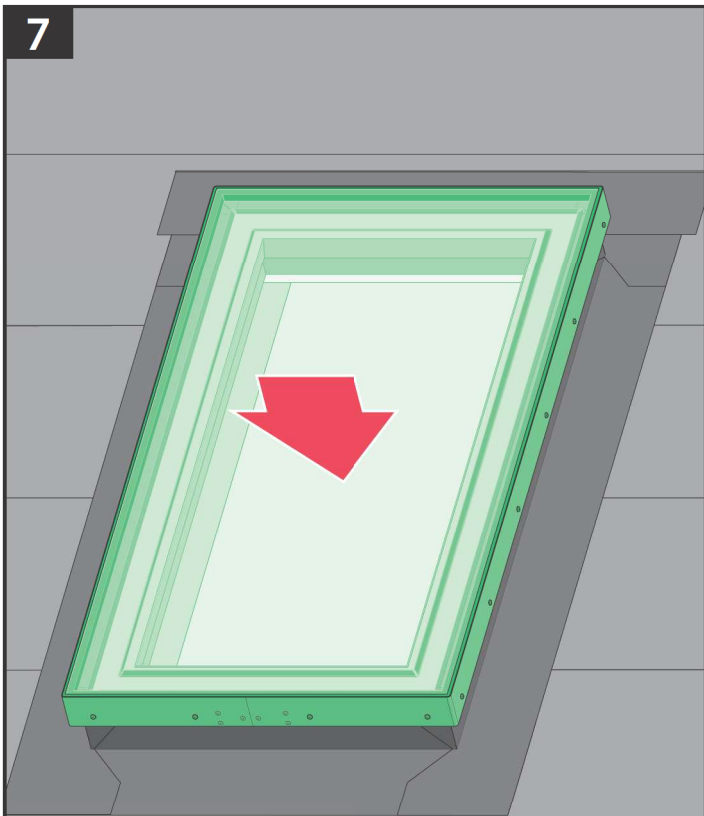

US	PDX installation on pitched roof with shingles.
FR	Installation du modèle PDX sur un toit en contreplaqué avec matériau de toiture plat.
ES	Instalación en un techo de madera triplay con material de techo plano.
KR	평평한 지붕재가 있는 합판 지붕에 PDX를 설치.

15°-60°
3/12-21/12

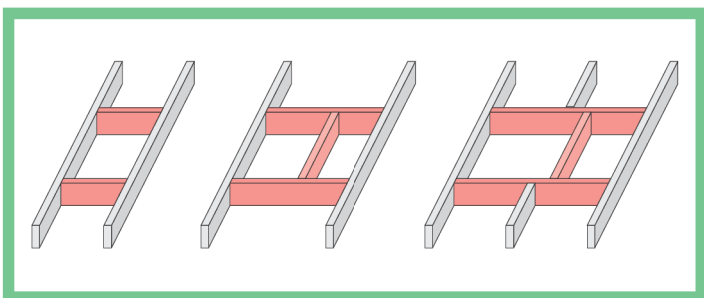
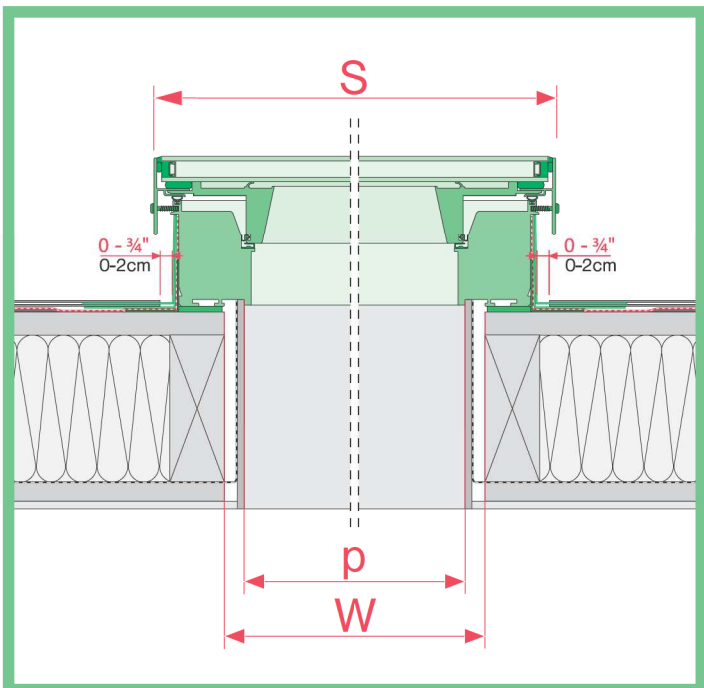
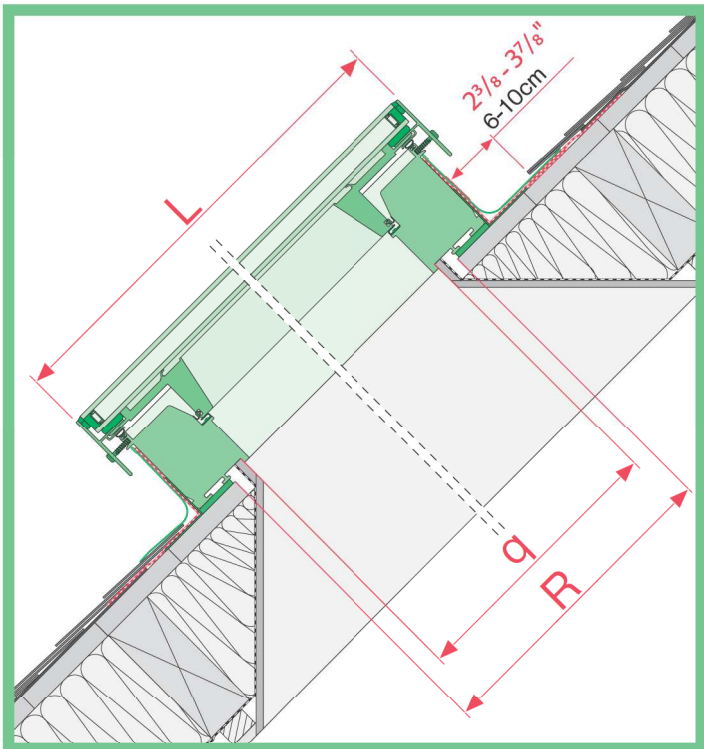
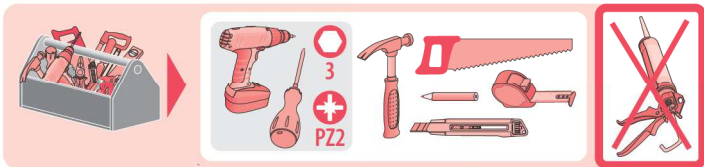

1*

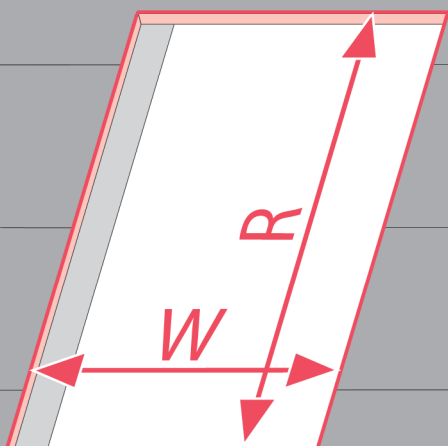

US Prepare the rough opening in the roof in the dimensions of WxR (dimensions W and R are provided in the table on page 2).

FR Ménagez dans le toit une ouverture brute de largeur (W) sur de hauteur (R) (voir la largeur W et la hauteur R dans un tableau à la page 2).

ES Prepare la abertura áspera en el techo con las dimensiones de WxR (las dimensiones WxR se indican en una tabla en la página 2).

KR 지붕의 대략적인 개구부를 WxR 치수로 준비합니다 (치수 W 및 R은 2 페이지의 표에 나와 있습니다).

2*

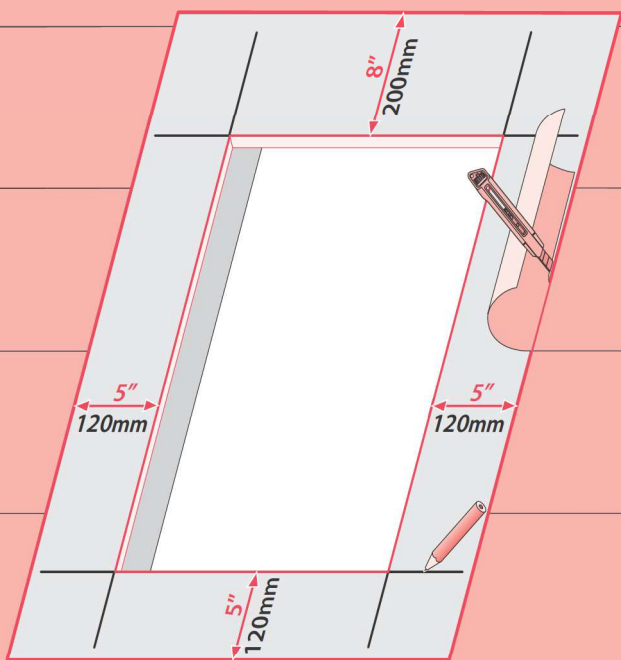

US Remove existing roofing underlayment around the opening.

FR Enlevez la sous-couche de toiture existante autour de l'ouverture.

ES Retire la capa de techo existente alrededor de la abertura.

KR 개구부 주변의 기존의 지붕 하지재를 제거하십시오.

3*

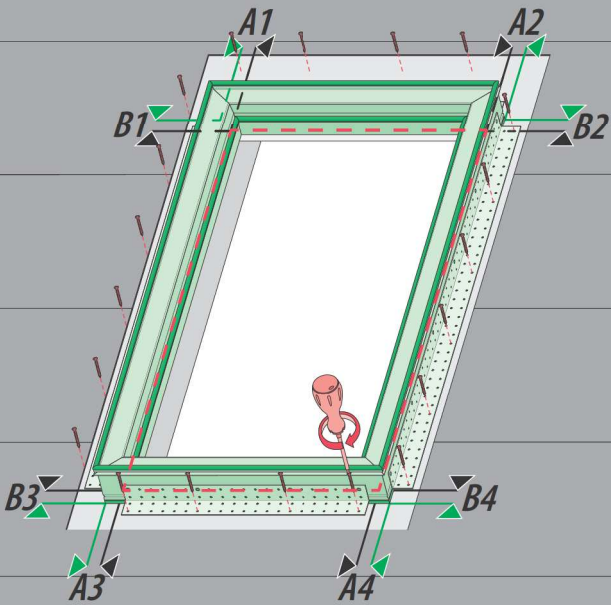
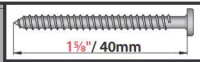

$$A1=A2=A3=A4$$

$$B1=B2=B3=B4$$

US Place the PDX skylight over the opening. Make sure the gaps between the opening and the skylight's frame are equal.

FR Placez la fenêtre de toit PDX au dessus de l'ouverture. Assurez-vous que les espaces entre l'ouverture et le cadre de la fenêtre sont égaux.

ES Coloque el tragaluz PDX (ventana) sobre la abertura. Observe y asegúrese de que los espacios entre la abertura y el marco de la claraboya sean iguales.

KR 개구부 위에 PDX 스카이라이트를 놓습니다. 개구부 사이의 틈새를 관찰하고 확인합니다. 그리고 천창의 프레임은 동일합니다.

4*

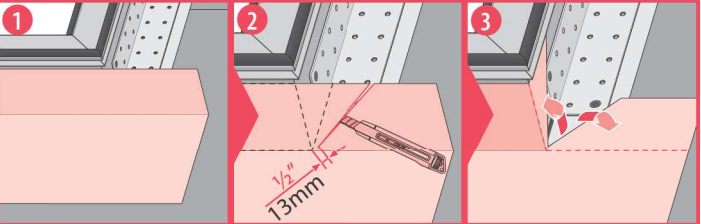
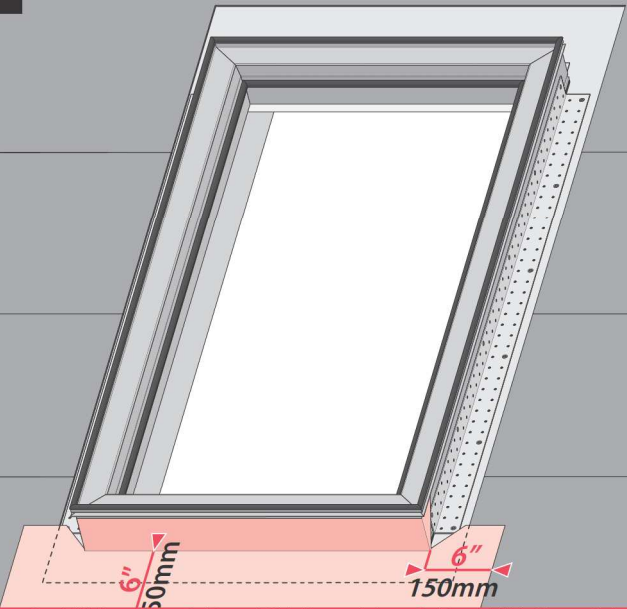

US For complete waterproofing, apply self-adhesive underlayment (separate purchase) starting at the bottom of the skylight.

FR Pour une étanchéité totale, utiliser le bande d'étanchéité repliable en partie basse (vendu séparément).

ES Para una impermeabilización completa, aplique un sellador autoadhesivo para techo (se compra por separado) comenzando en la parte inferior del tragaluz.

KR 완전방수를 위해서는 천창 밑부분부터 자가접착식 밀갈개(별매)를 설치해주세요..

5*

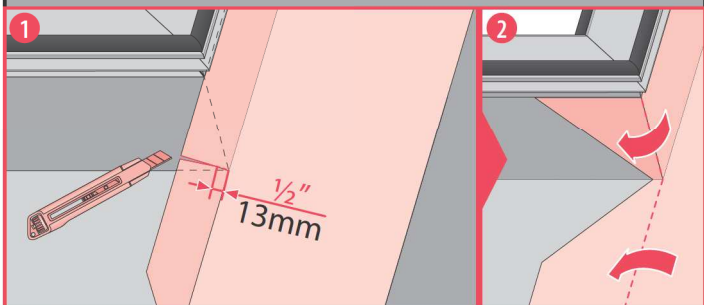
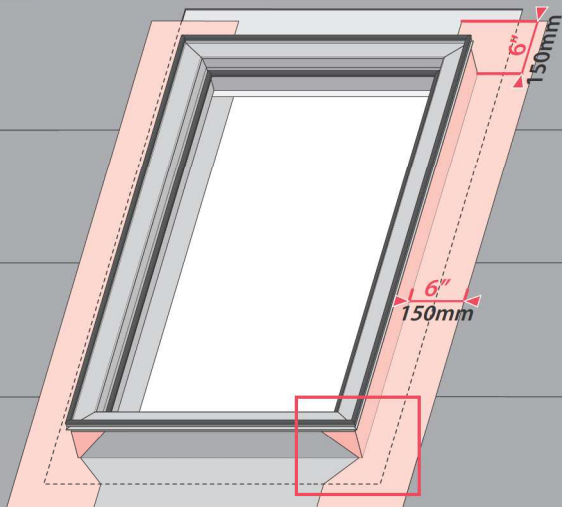

US	Apply self-adhesive underlayment on the sides of the skylight.
FR	Appliquez une sous-couche autocollante sur les côtés de la bordure.
ES	Applique una capa autoadhesiva en la parte superior de la ventanas.
KR	커브 측면에 자체 접착성 하지재를 붙이세요.

6*

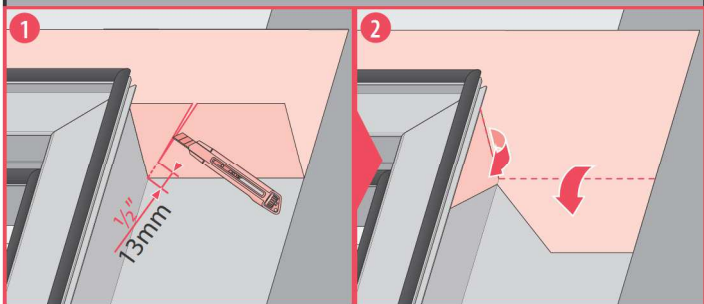
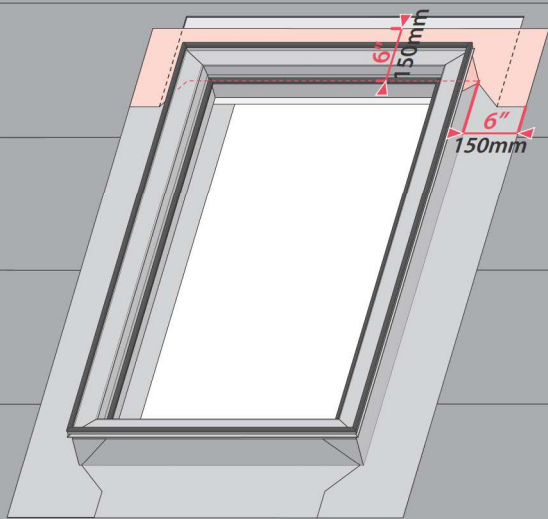

US	Apply self-adhesive underlayment on the top part of the skylight.
FR	Appliquez une sous-couche autocollante sur la partie supérieure de la bordure.
ES	Applique una capa autoadhesiva en la parte superior de la ventanas.
KR	커브 윗부분에 자체 접착성 하지재를 붙이세요.

7a*

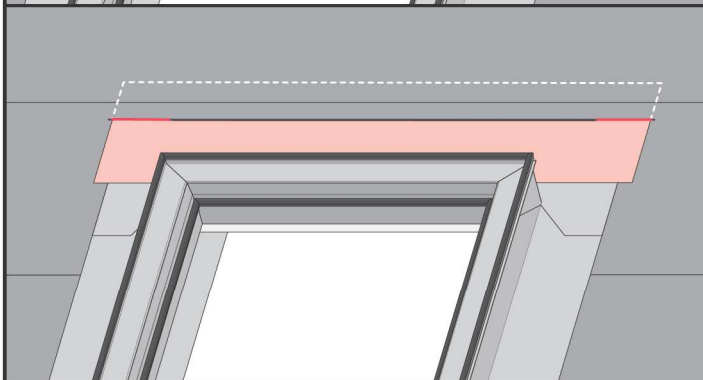
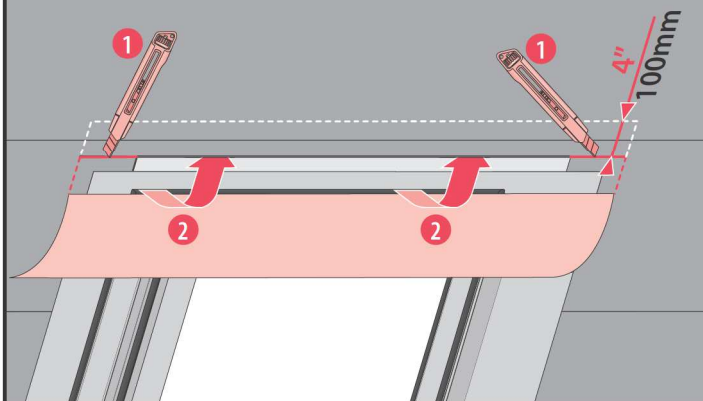

US	To ensure proper water drainage, interweave the skylight's underlayment with the existing roof underlayment (retrofit).
FR	Pour assurer le drainage adéquat de l'eau, entrelacez la sous-couche de la fenêtre de toit avec la sous-couche existante du toit (rénovation).
ES	Para garantizar un drenaje adecuado del agua, entrelace la capa inferior del tragaluz con la capa de techo existente.
KR	적절한 배수가 되게하려면 천창의 하지재를 기존지붕의 하지재에 끼워 넣습니다(새롭게 장착).

7b*

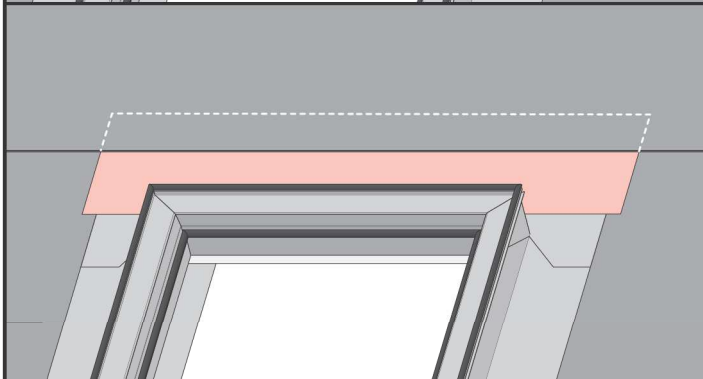
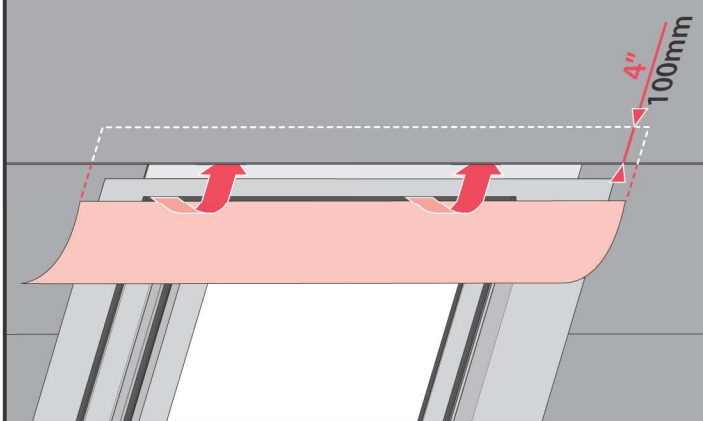

US	To ensure proper water drainage, interweave the skylight's underlayment with the new roof underlayment (new construction).
FR	Pour assurer le drainage adéquat de l'eau, entrelacez la sous-couche de la fenêtre de toit avec la sous-couche neuve (nouvelle construction).
ES	Para garantizar un drenaje adecuado del agua, entrelace la capa inferior del tragaluz con la nueva capa de techo.
KR	적절한 배수가 되게하려면 천창의 하지재를 새로운 지붕하지재에 끼워 넣습니다(새로운 시공).

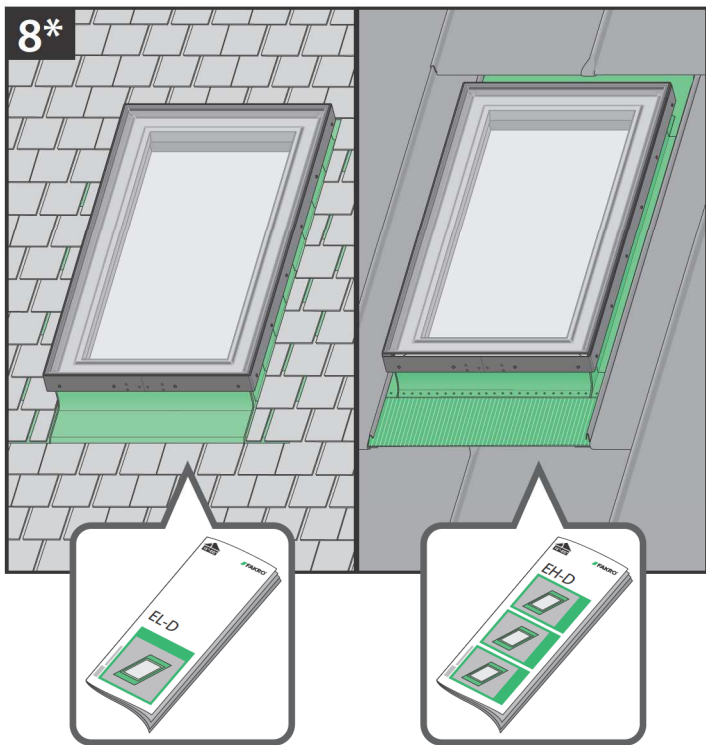

US	Install adequate aluminum flashing kit purchased separately. Use EL-D flashing for shingle roofs or EH-D flashing for high profiled materials. See installation instructions supplied with the flashing.
FR	Installer un raccord d'étanchéité avec un tablier en aluminium, qui doit être acheté séparément. Utiliser le raccord EL-D pour les toits en bardeaux ou le raccord EH-D pour les toitures ondulées. Consulter les instructions d'installation fournies avec le raccord.
ES	Instale un juego de tapajuntas de aluminio adecuado comprado por separado. Use tapajuntas EL-D para techos de tejas o tapajuntas EH-D para materiales de alto perfil. Consulte las instrucciones de instalación suministradas con el tapajuntas.
KR	별도로 구입한 적합한 알루미늄 후레싱 키트를 설치하십시오. 싱글 지붕에는 EL-D 후레싱을 사용하거나, 고사양의 제품의 EH-D 후레싱을 사용합니다. 후레싱과 함께 제공된 설치 지침을 참조하십시오.

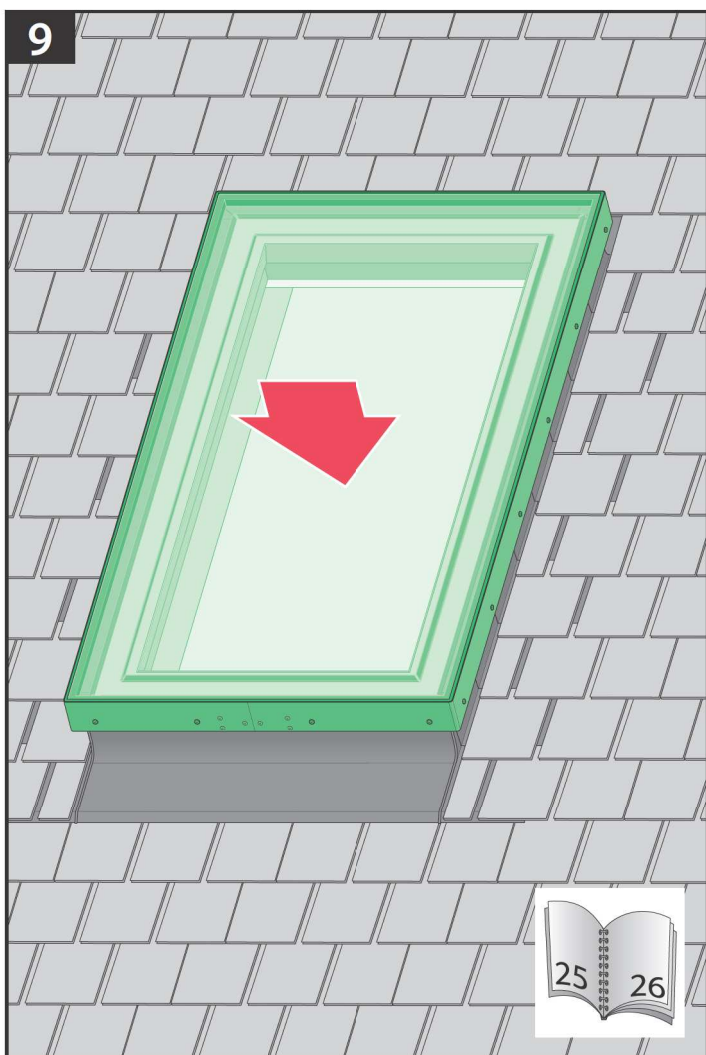

US	PDX installation on pitched roof with profiled roofing material.
FR	Installation du modèle PDX sur un toit avec matériau de toiture profilé.
ES	Instalación en un techo con material de techo perfilado.
KR	프로파일 지붕 재료가있는 지붕에 PDX를 설치.

 15°-60°
 3/12-21/12

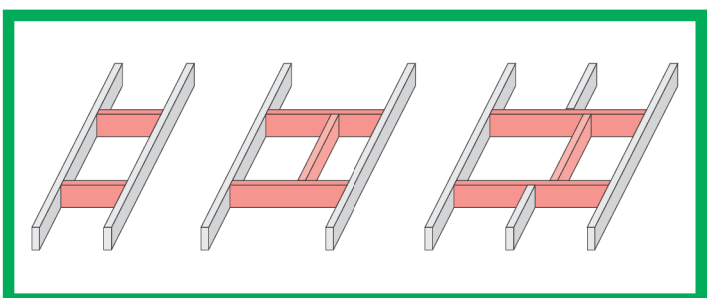
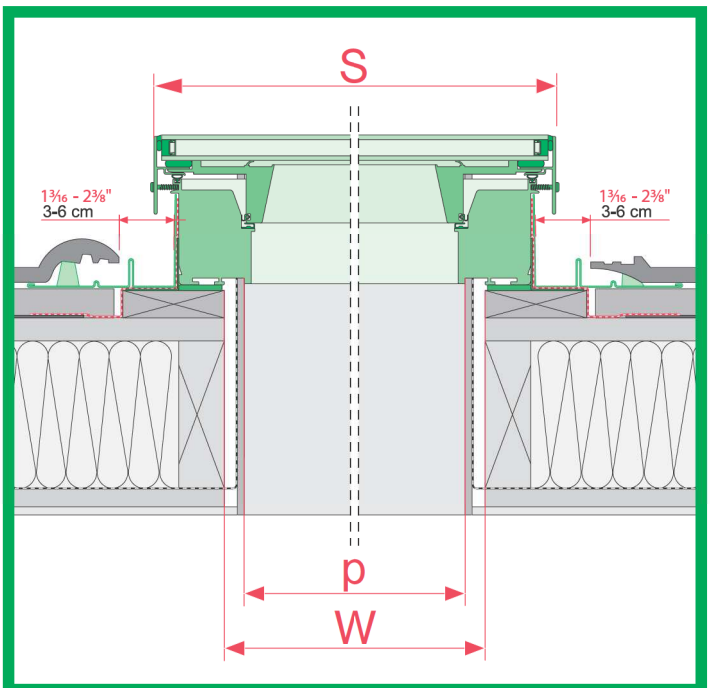
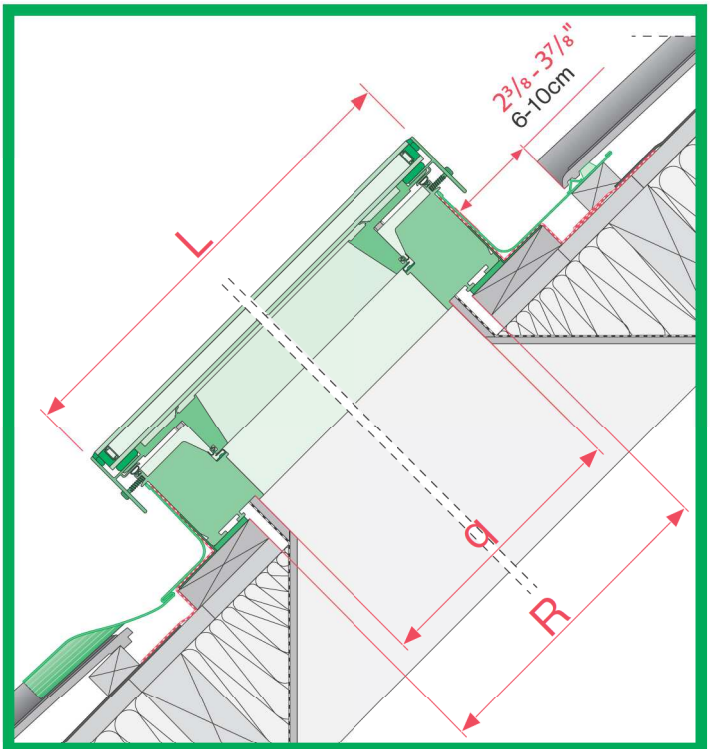
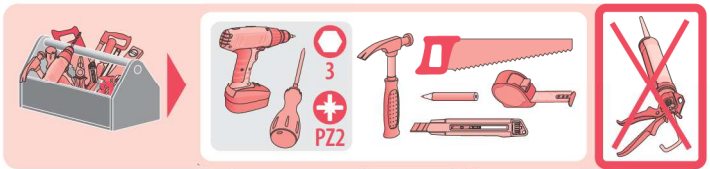

1**

X = 4"-5" / 100÷130mm

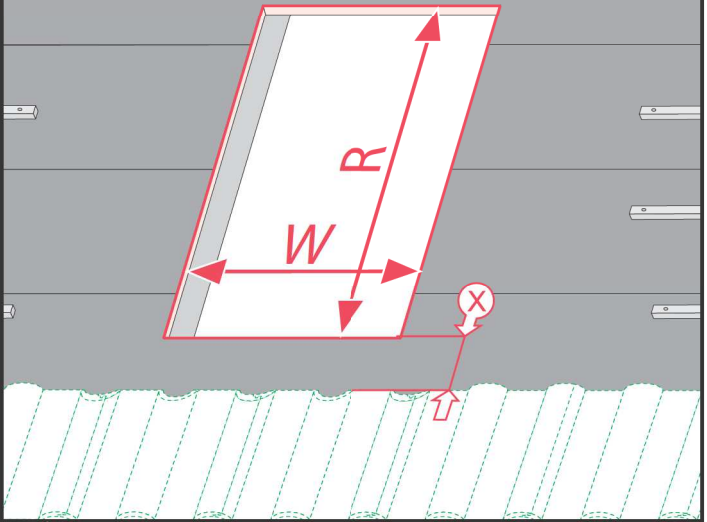

US	<p>Prepare the rough opening in the roof using the WxR dimensions (dimensions W and R are provided in the table on page 2). Place wooden battens around the opening. Battens should be of the same thickness as battens used for roofing material.</p> <p>Top parts of tiles or profiled metal sheets, must be prepared as shown in the flashing installation instruction. Temporarily remove the battens around the rough opening. Keep the distance between the rough opening and the top edge of the roofing material.</p>
FR	<p>Ménagez dans le toit une ouverture brute de largeur (W) sur de hauteur (R) (voir la largeur W et la hauteur R dans un tableau à la page 2). Placez des liteaux de bois tout autour. Les liteaux doivent être de la même épaisseur que les liteaux utilisés pour le matériau de toiture.</p> <p>Il faut préparer le dessus des tuiles ou des tôles profilées comme indiqué dans les instructions d'installation du solin. Retirez temporairement les liteaux autour de l'ouverture brute. Maintenez la distance entre cette dernière et la bordure supérieure du matériau de toiture.</p>
ES	<p>Prepare la abertura áspera en el techo con las dimensiones de WxR (las dimensiones WxR se indican en una tabla en la página 2). Coloque los listones de madera alrededor de la abertura. Los listones deben ser del mismo grosor que los utilizados para material de techado.</p> <p>Las partes superiores de las baldosas o chapas metálicas perfiladas, deben prepararse como se muestra en la instrucción de instalación parpadeante. Retire temporalmente los listones alrededor de la abertura rugosa. Mantenga distancia entre la abertura áspera y el borde superior del material de la cubierta.</p>
KR	<p>지붕의 대략적인 개구부를 WxR 치수로 준비합니다 (치수 W 및 R은 2 페이지의 표에 나와 있습니다). 개구부 주변에 나무 판을 놓으십시오. 판재는 지붕재에 사용되는 판재와 같은 두께이어야 합니다. 타일 또는 프로파일링된 금속시트의 상단부분은 후레싱 설치 지침에 표시된대로 준비해야 합니다. 대략적인 개구부 주변의 판금을 임시로 제거하십시오. 대략적인 개구부와 지붕재의 상단 가장자리 사이의 거리를 유지하십시오.</p>

2**

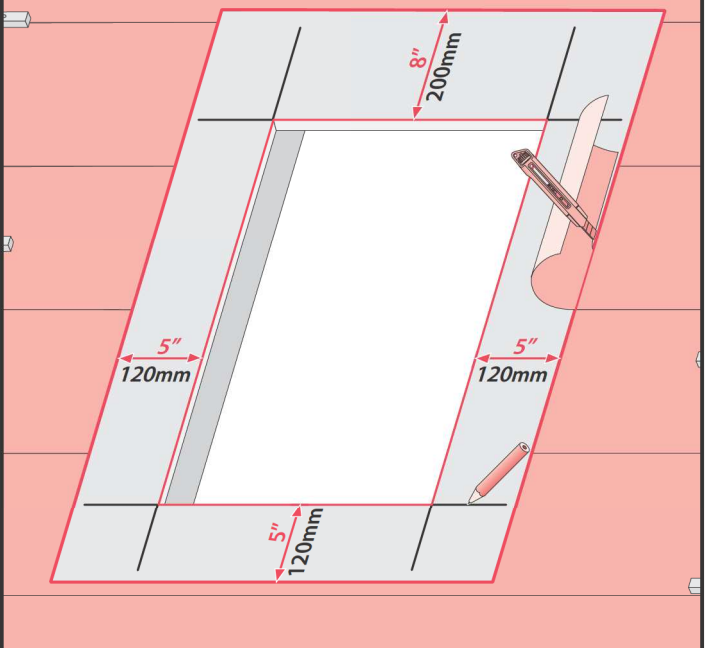

US	Remove existing roofing underlayment around the opening.
FR	Enlevez la sous-couche de toiture existante autour de l'ouverture.
ES	Retire la capa de techo existente alrededor de la abertura.
KR	개구부 주변의 기존 지붕 하지재를 제거하십시오.

3**

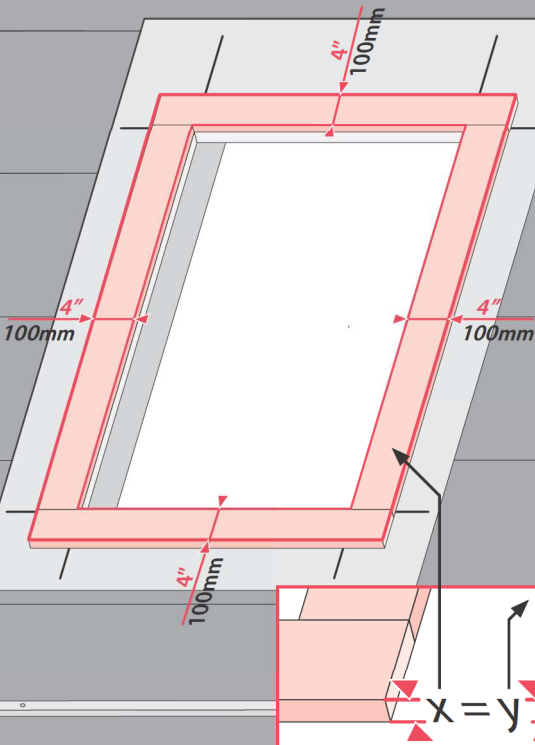

US	Place 4" (100mm) wide battens around the rough opening. Skip this step if your roof has no battens. Battens should be of the same thickness as battens used for the roofing material.
FR	Mettez en place les liteaux de 100 mm (4 po) de largeur autour de l'ouverture brute. Les liteaux doivent être de la même épaisseur que les liteaux utilisés pour le matériau de toiture.
ES	Coloque listones con un ancho de 4" (100mm) alrededor. Los listones deberán ser del mismo grosor que los listones utilizados para el material de techados.
KR	100 x 100mm 크기의 각재들을 개구부 주위를 둘러놓고 고정하세요. 이때, 각재들은 지붕 하자각재와 동일한 두께로 시공해야 합니다.

4**

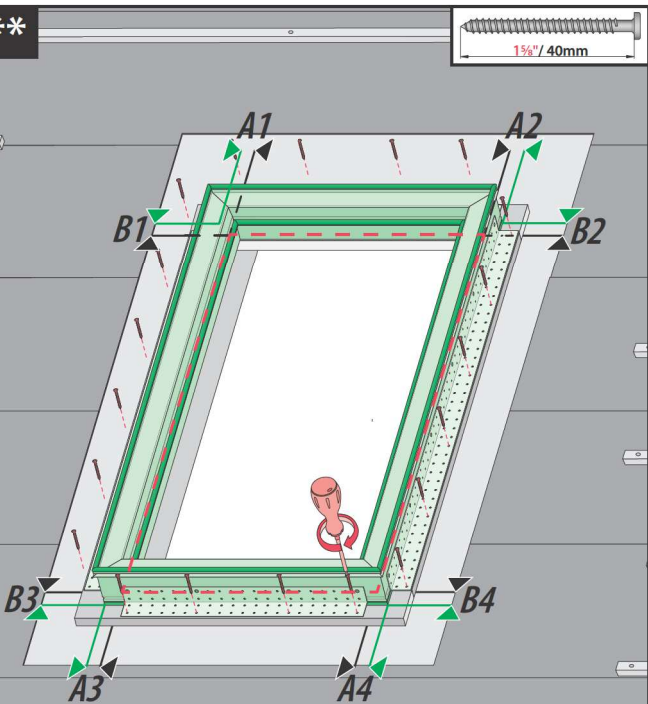

A1=A2=A3=A4

B1=B2=B3=B4

US	Place the PDX skylight over the opening. Make sure the gaps between the opening and the skylight's frame are equal.
FR	Placez la fenêtre de toit PDX au dessus de l'ouverture. Assurez-vous que les espaces entre l'ouverture et le cadre de la fenêtre sont égaux.
ES	Coloque el tragaluz PDX (ventana) sobre la abertura. Observe y asegúrese de que los espacios entre la abertura y el marco de la claraboya sean iguales.
KR	개구부 위에 PDX 스카이라이트를 놓습니다. 개구부 사이의 틈새를 관찰하고 확인합니다. 그리고 천창의 프레임은 동일합니다.

5**

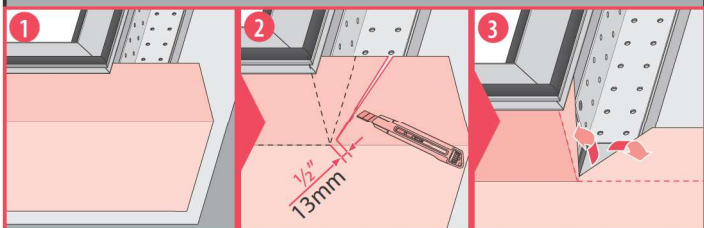
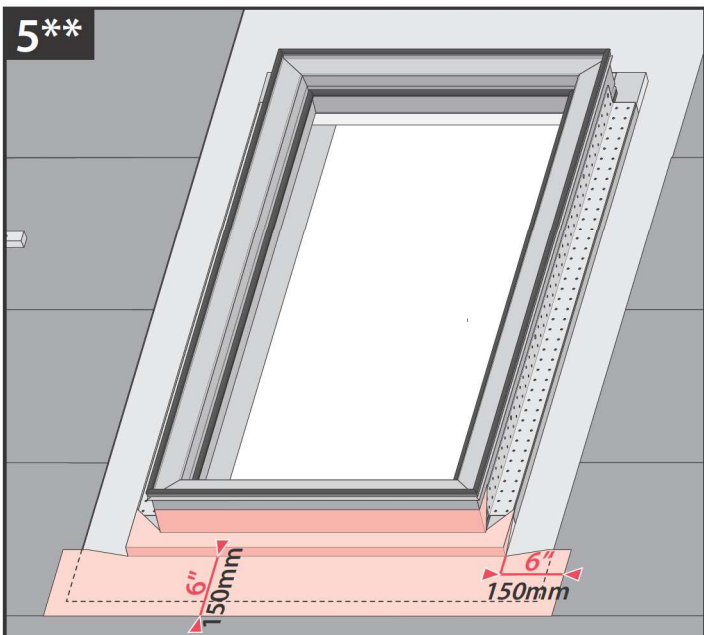

US	For complete waterproofing, apply self-adhesive underlayment (separate purchase) starting at the bottom of the skylight.
FR	Pour une étanchéité totale, utiliser le bande d'étanchéité repliable en partie basse (vendu séparément).
ES	Para una impermeabilización completa, aplique un sellador autoadhesivo para techo (se compra por separado) comenzando en la parte inferior del tragaluz.
KR	완전방수를 위해서는 천장 밑부분부터 자가접착식 밀결개(별매)를 설치해주세요.

6**

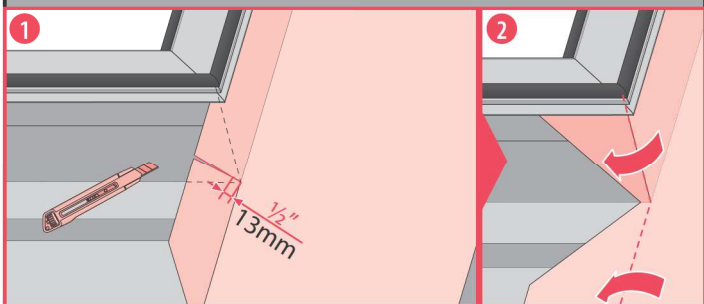
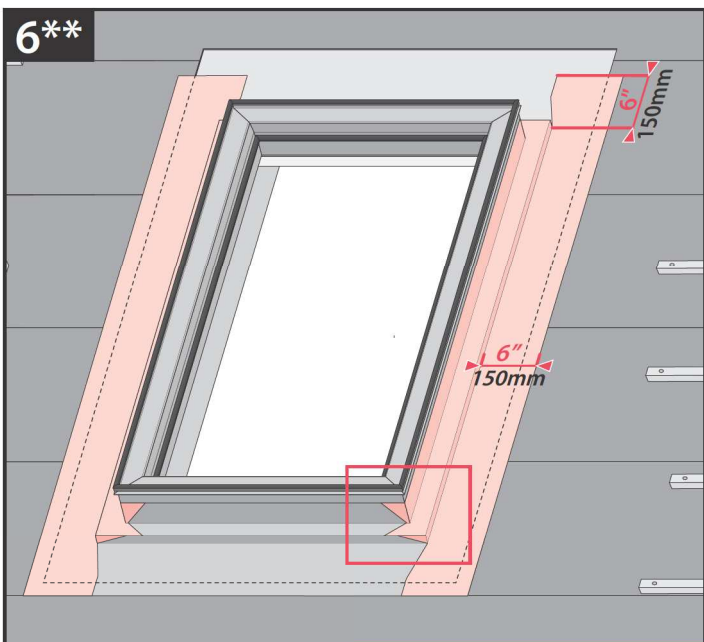

US	Apply self-adhesive underlayment on the sides of the skylight .
FR	Appliquez une sous-couche autocollante sur les côtés de la bordure.
ES	Aplique una capa autoadhesiva en la parte superior de la acera.
KR	커브 측면에 자체 접착성 하지재를 붙이세요.

7**

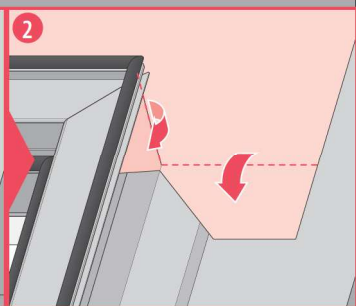
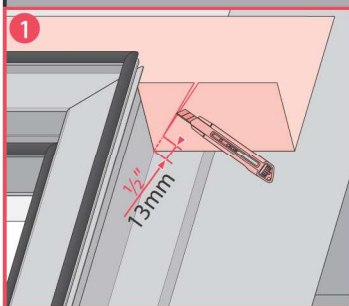
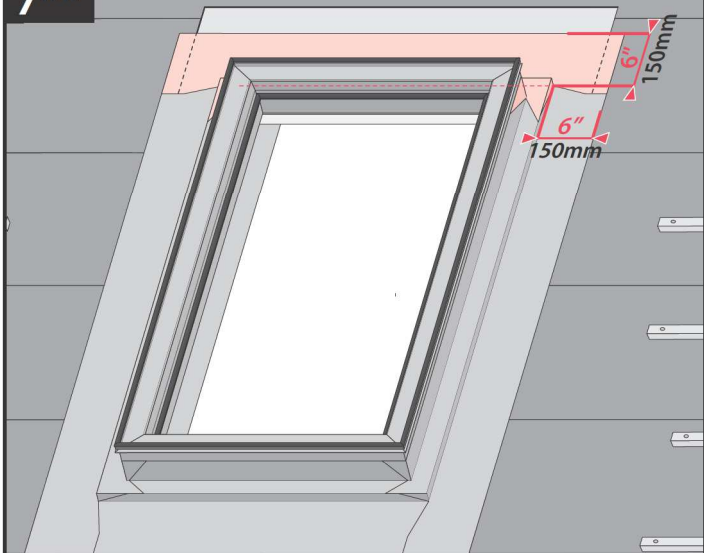

US	Apply self-adhesive underlayment on the top part of the skylight.
FR	Appliquez une sous-couche autocollante sur la partie supérieure de la bordure.
ES	Para garantizar un drenaje adecuado del agua, entrelace la capa inferior del tragaluz con la nueva capa de techo.
KR	커브 윗부분에 자체 접착성 하지재를 붙이세요.

8a**

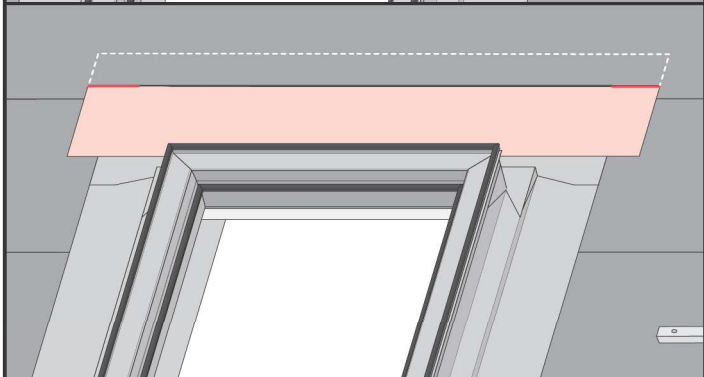
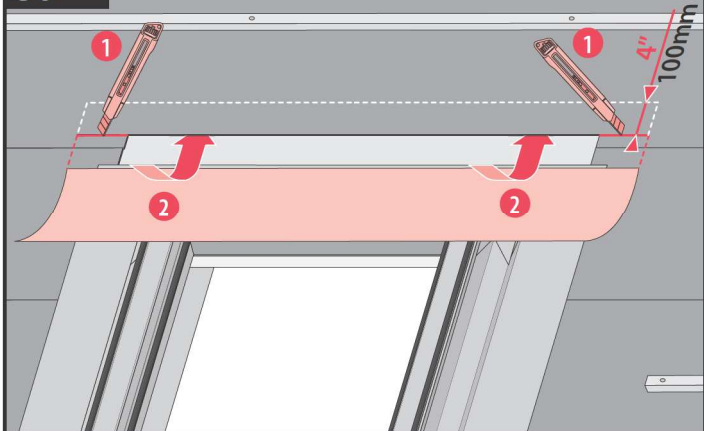

US	To ensure proper water drainage, interweave the skylight's underlayment with the existing roof underlayment (retrofit).
FR	Pour assurer le drainage adéquat de l'eau, entrelacez la sous-couche de la fenêtre de toit avec la sous-couche existante du toit (rénovation).
ES	Para garantizar un drenaje adecuado del agua, entrelace la capa inferior del tragaluz con la nueva capa de techo.
KR	적절한 배수가 되게하려면 천창의 하지재를 기존 지붕하지재에 끼워 넣습니다 (새롭게 장착).

8b**

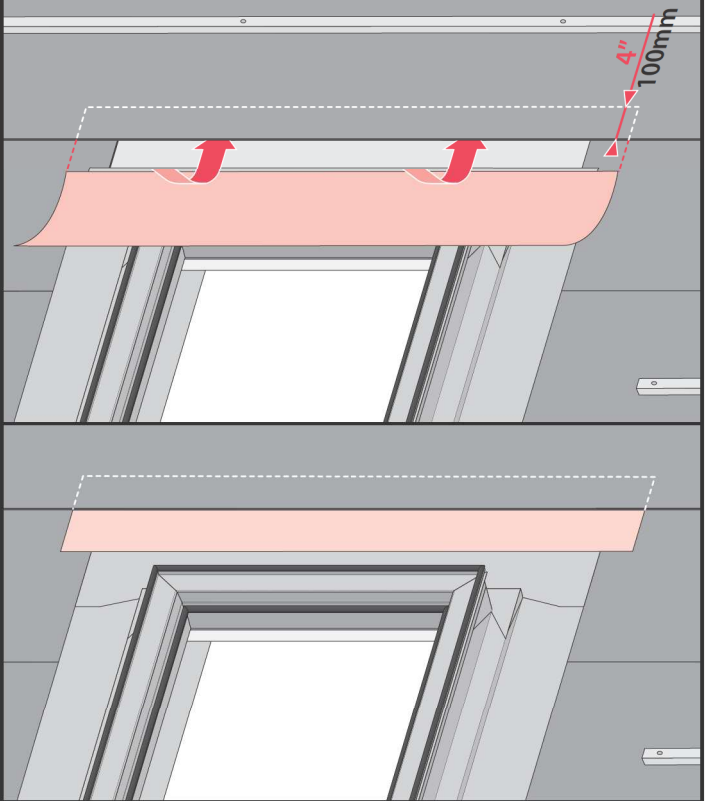

US	To ensure proper water drainage, interweave the skylight's underlayment with the new roof underlayment (new construction).
FR	Pour assurer le drainage adéquat de l'eau, entrelacez la sous-couche de la fenêtre de toit avec la sous-couche neuve (nouvelle construction).
ES	Para garantizar un drenaje adecuado del agua, entrelace la capa inferior del tragaluz con la nueva capa de techo.
KR	적절한 배수가 되게하려면 천창의 하지재를 새로운 지붕하지재에 끼워 넣습니다 (새로운 시공).

9**

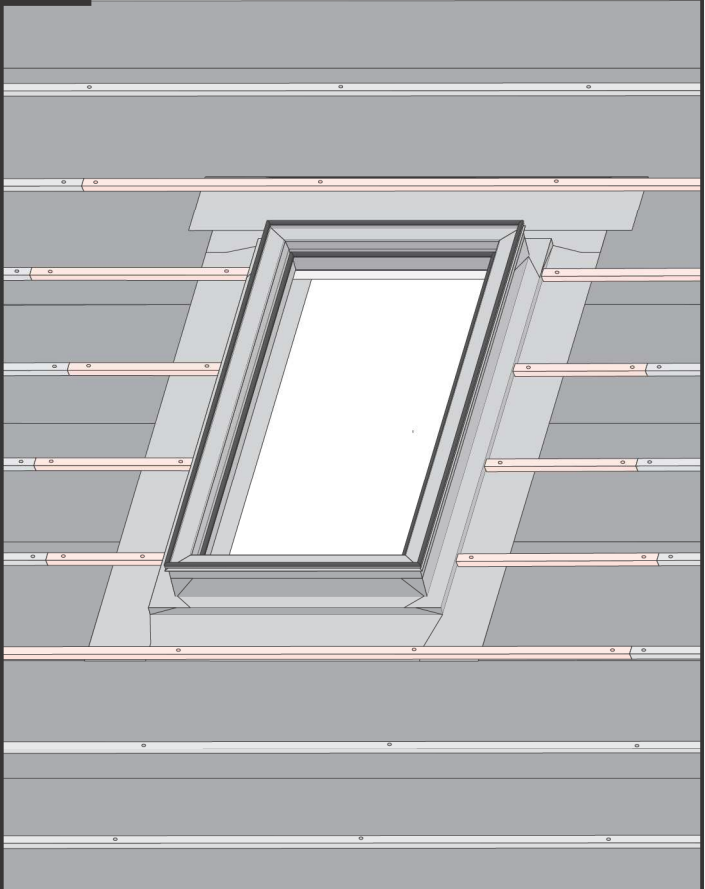

US	Replace the battens around the rough opening. Skip this step if your roof has no battens.
FR	Remettez en place les liteaux autour de l'ouverture brute.
ES	Reemplace los listones alrededor de la abertura áspera.
KR	대략적인 개구부 주위의 각상을 교체하십시오.

10**

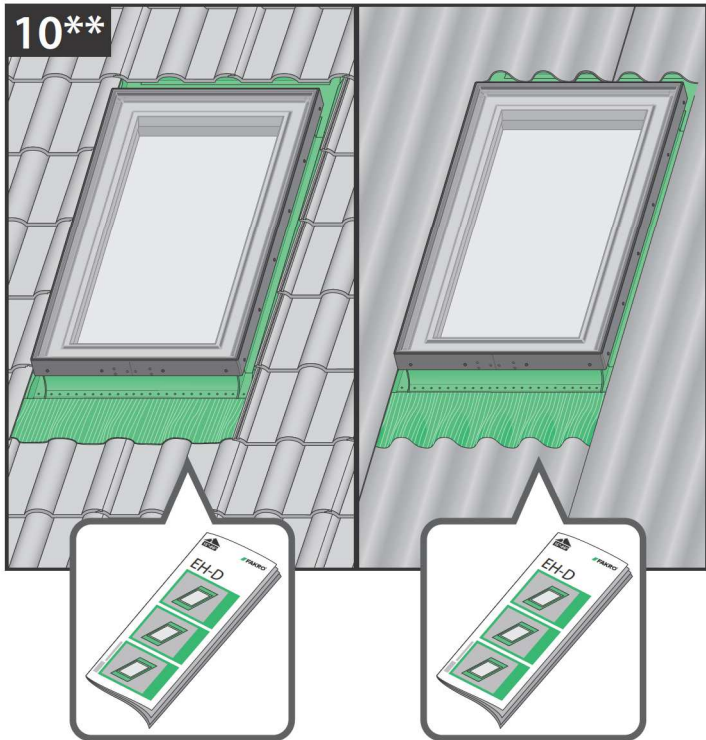

US	Install adequate aluminum flashing kit purchased separately. Use EL-D flashing for shingle roofs or EH-D flashing for high profiled materials. See installation instructions supplied with the flashing.
FR	Installer un raccord d'étanchéité avec un tablier en aluminium, qui doit être acheté séparément. Utiliser le raccord EL-D pour les toits en bardeaux ou le raccord EH-D pour les toitures ondulées. Consulter les instructions d'installation fournies avec le raccord.
ES	Instale un juego de tapajuntas de aluminio adecuado comprado por separado. Use tapajuntas EL-D para techos de tejas o tapajuntas EH-D para materiales de alto perfil. Consulte las instrucciones de instalación suministradas con el tapajuntas.
KR	별도로 구입한 적합한 알루미늄 후레싱 키트를 설치하십시오. 싱글 지붕에는 EL-D 후레싱을 사용하거나, 고사양의 제품의 EH-D 후레싱을 사용합니다. 후레싱과 함께 제공된 설치 지침을 참조하십시오.

11

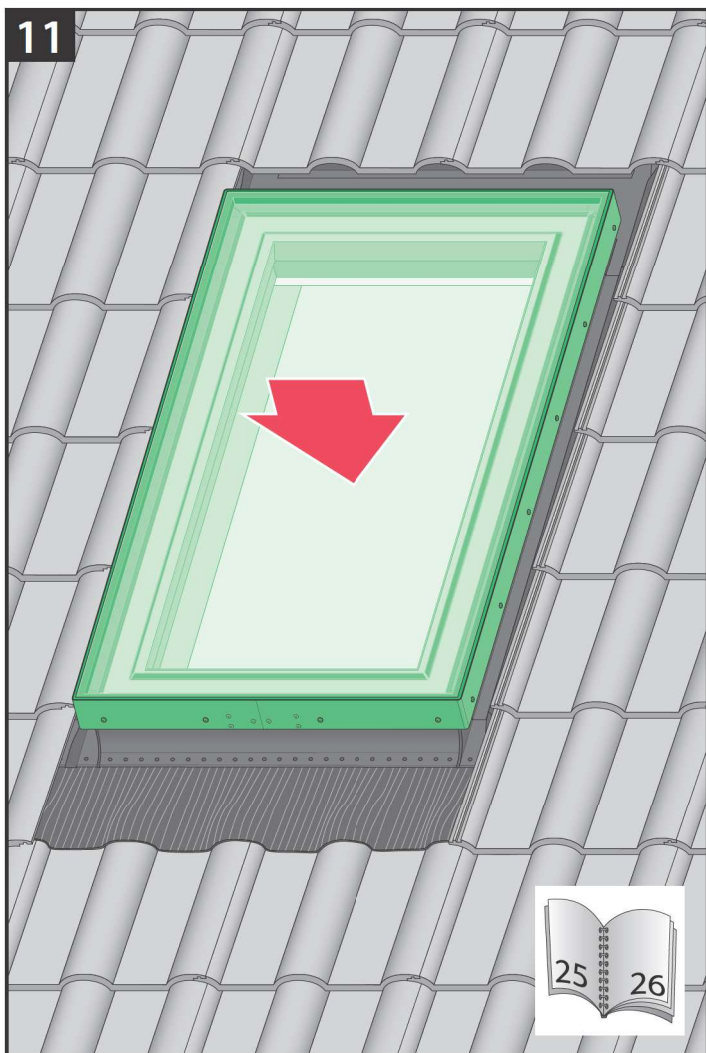

1

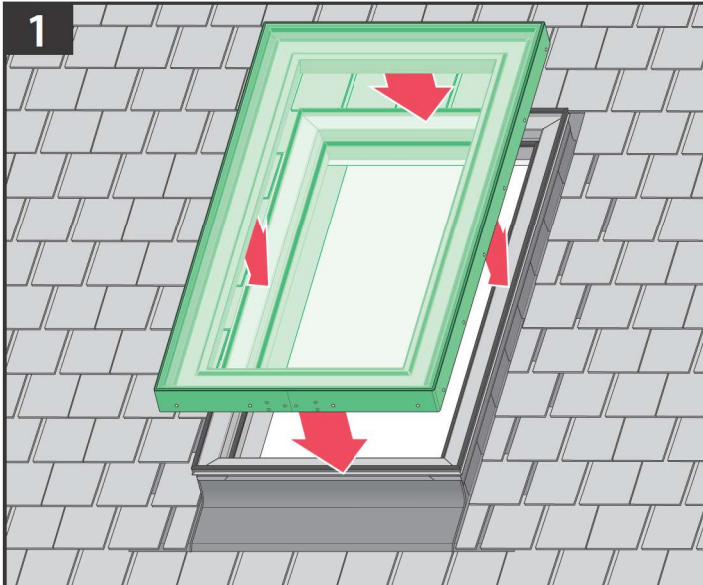

US Final step of the installation.

FR Dernière étape de l'installation.

ES Último paso de la instalación.

KR 설치의 마지막 단계.

2

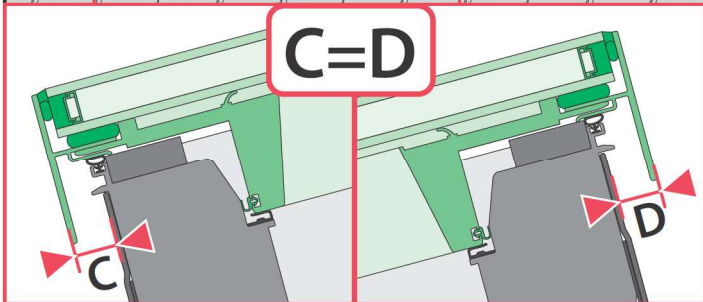
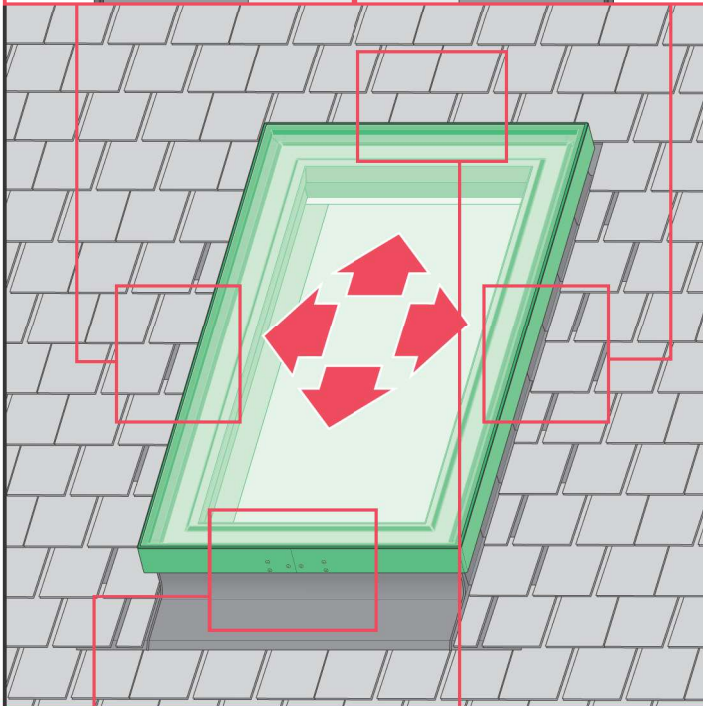
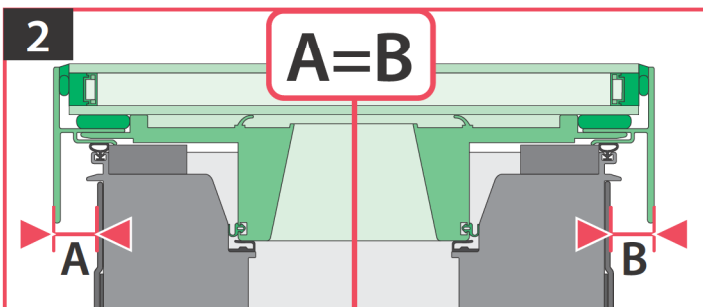

US Place the skylight sash on the frame.

FR Placez le châssis du puits de lumière sur le cadre.

ES Fije la hoja del tragaluz al marco con tornillos.

KR 프레임 위에 스카이라이트 창틀을 놓습니다.

3

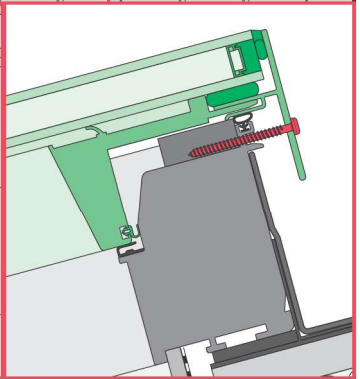
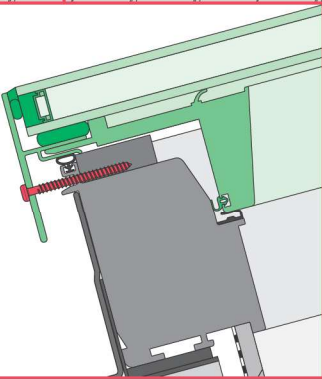
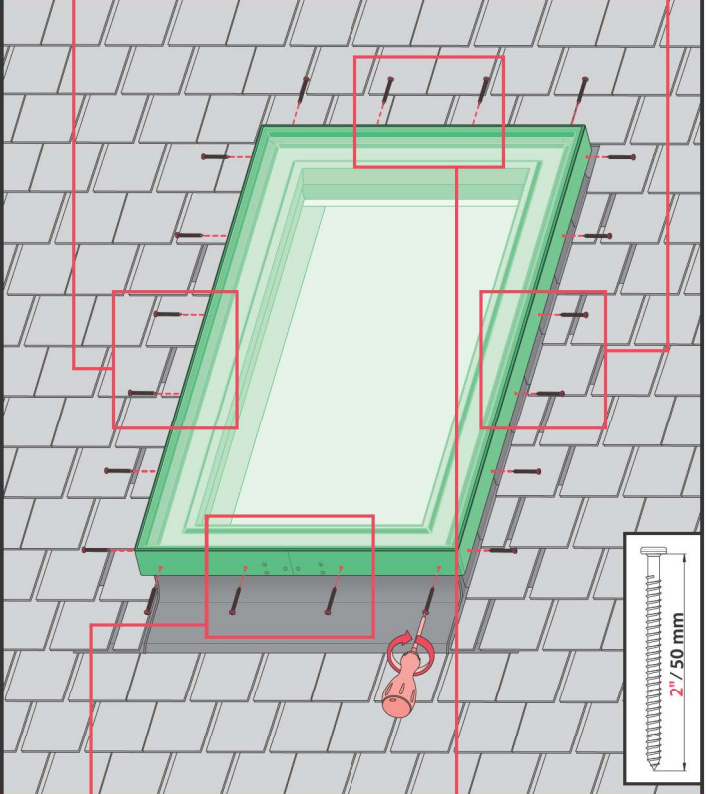
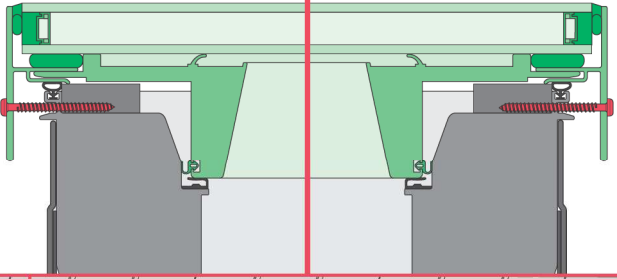

US Secure the sash with the screws to the frame.

FR Fixez le châssis avec les vis au cadre.

ES Fije la cuchilla al marco con tornillos.

KR 나사를 이용해 창틀에 고정합니다.

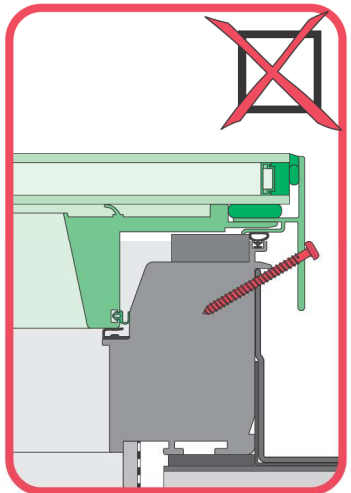
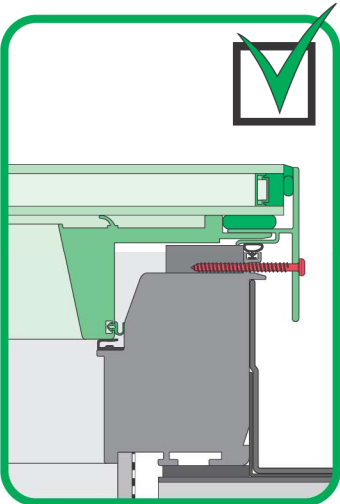

US	Manufacturer and Seller shall bear no liability for failure to comply with the applicable laws, building codes and safety requirements by the user of the product, architect, fitter or owner of the building.
FR	Le fabricant et le revendeur ne prend aucune responsabilité de ne pas respecter les lois applicables, les règlements sur les bâtiments et les exigences de sécurité par l'utilisateur du produit, l'architecte, l'installateur ou le propriétaire du bâtiment.
ES	El fabricante y el vendedor no tienen ninguna responsabilidad por el incumplimiento de la ley vigente, normas de construcción y exigencias de seguridad por parte del usuario del producto, arquitecto, instalador o el propietario del edificio.
KR	소비자, 건물주, 설계자, 설치자가 요구하는 법규, 규정, 안전조치에 부합하지 않는 것에 대해 제조사나 판매자는 법적 책임이 없습니다.