



PL

<https://www.fakro.pl/serwis/gwarancja/>



GB

<https://www.fakro.com/service/customer-service/>

FAKRO Sp. z o.o.

Ul. Węgierska 144A, 33-300 Nowy Sącz
Polska
www.fakro.com
tel. +48 18 444 0 444, fax +48 18 444 0 333

Warranty details:

Product _____

Model _____

Serial number _____

Seller _____

Address _____

Purchase date _____

Invoice no. _____

Signature (stamp) of person installing a device



ORIGINAL USER MANUAL 2/3

ELECTRICALLY OPERATED LOFT LADDER
LET

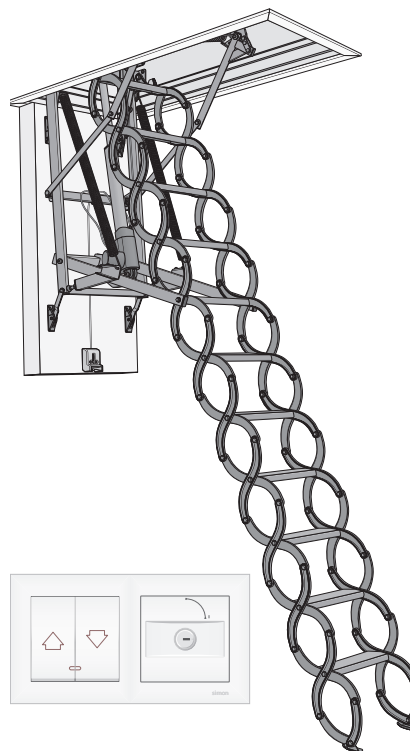

SAFETY RULES	2
WIRING DIAGRAM	3
CONTROLLER INSTALLATION	4
PROGRAMMING	6
LOFT LADDER LOCK	6
DECLARATION OF CONFORMITY	6
CONTROL	7
EMERGENCY UNLOCK	8
TROUBLESHOOTING	9
ADDITIONAL FUNCTIONS	10
Z-WAVE DEVICES COMPATIBILITY	10
ADVANCED INFORMATION	10
WARRANTY	12

NC907-GB_LET-Z-Wave_ZWMS_24.04.17_FAKRO_KB3595



<http://www.fakro.com/download/film-installation-instructions/roof-windows/>



FAKRO Sp. z o.o.
ul. Węgierska 144A, 33-300 Nowy Sącz, PL
tel. +48 18 4440444, fax +48 18 4440333
www.fakro.com

SET DESCRIPTION

The set of electrically operated loft ladder consists of scissor ladder, 24VDC actuator, ZWMS control module with wall switches, 24V DC power supply unit.

The control module has a built-in Z-Wave radio interface for direct control of the loft ladder via a remote control.

The module also has two potential-free control inputs for wired control using a wall switch.

It is recommended to install a wall lock with a key to prevent unauthorised or accidental use of the loft ladder.

TECHNICAL SPECIFICATION

POWER SUPPLY UNIT	ACTUATOR	RADIO MODULE ZWMS	
Input voltage: 100-240V AC ~50/60Hz Rated power: 120W Output voltage: 24V DC	Power voltage: 24V DC Maximum pushing force: 5000N Actuator working cycle: 10%, max 2min ON/ 18min OFF	Radio protocol: Z-Wave Reach: up to 20 m in a building Working temperature: -10 do +70°C	Frequency: EU – 868.4 MHz AS/NZ – 921.42 MHz US/Canada – 908.4 MHz RU – 869 MHz (depending on version)

SAFETY RULES



CAUTION! MOVING PARTS, WATCH OUT FOR FINGERS AND OTHER BODY PARTS!

- After unpacking, check the LET type loft ladder elements for any signs of mechanical damage.
- Plastic containers used for packing should be stored out of children reach as they may be a potential source of danger.
- The control set is designed for installation below 2000 m above sea level. Install the set preferably on the ceiling or above the ceiling but below 2 m.
- The installation of the LET type loft ladder and the connection of the system must be performed in accordance with the included instructions by a qualified installer. Incorrect system connection and incorrect installation of the controller cover may be a source of fire hazard.
- A dedicated power supply unit must be used.
- Before connecting the LET type loft ladder, make sure that the power voltage corresponds with motor voltage specified on the data plate.
- The LET type loft ladder must be used according to its intended design.
- The electrical system should include an easily accessible double-pole disconnector with a contact separation of at least 3 mm.
- Potential-free control cables through the connector must not be longer than 30 m.
- The system supplying the set should be protected by means of a 10A fuse.
- Safety rules must be strictly observed. The LET type loft ladder comes with the electric actuator. Using the actuator installed to operate the loft ladder poses a risk of personal injuries. Although the mechanism of the actuator is equipped with an overload switch, forces present there are strong enough to cause physical injuries.
- This LET type loft ladder is not designed for use by people (including children) with reduced physical, sensory or mental capabilities or by people that do not have experience or knowledge of the equipment, unless it is done under supervision or according to the product original user manual provided by a person responsible for their safety.
- Opening and closing of the LET type loft ladder must be performed only in visual contact with the loft ladder being operated.
- A safety zone must be separated around installed LET type loft ladder to eliminate the risk of crushing injuries.
- It is forbidden to activate/fold up the LET type loft ladder when the user is on the ladder.
- It is recommended to install a barrier around the ceiling opening to protect against falling.
- Danger of slipping and falling from the ladder due to improper use.
- Danger of using the LET type loft ladder with a ladder that has not been properly adjusted to the room height (the ladder brackets must have properly adjusted support screw).
- Before each use, make sure that the ladder touches the ground after unfolding.
- The electrical socket and plug must be easily accessible.
- It is required to disconnect the loft ladder from the network using the cable plug included in the set:
- During any activities related to cleaning, adjustment or dismantling the electric parts of the LET type loft ladder.
- During storm with lightning and thunder.
- In the event of visible traces of water stains on the loft ladder components, then their drying and inspecting the LET type loft ladder components is required. During this time opening and operating the loft ladder only by the emergency opening mechanism.
- Loft ladder electric components must not be washed using solvent-based substances or open stream of water (do not immerse in water).
- Any repairs of the LET type loft ladder must be carried out by service authorised by the manufacturer. Any interference with the controller, excluding the connection part, will void the warranty and may result in product malfunction and/or fire hazard.
- The product should be periodically inspected after every 400 cycles of operation (1 cycle = opening – closing) but not less frequently than every 12 months. The inspection must be carried out by an authorised person.
- It is required to use personal safety devices and measures due to the risk of injury during maintenance/service operations by a closing/opening hatch or a folding/unfolding ladder.

Z-WAVE CONFIGURATION PARAMETERS

Parameter	Parameter no.	Value	Default value	SET (sending)	GET (querying)
Service counter reset	91	0 1 2	-	0 - reset service counter	1 – Service counter has not exceeded 400 cycles 2 – Service counter has exceeded 400 cycles
Service counter since last reset	92	1 ... 255	-	-	read value * 10 = number of cycles
Counter of cycles completed	93	1 ... 255	-	-	read value * 10 = number of cycles
Default settings	99	1 2	1	1 – default parameters 2 – parameters other than the default	1 – default parameters 2 – parameters other than the default
Autoexclusion	100	1 2	1	2 – autoexclusion	-

COMMAND CLASSES

Command Classes	Role	
	Support	Control
Command Class Z-Wave+ Info v2	ok	
Command Class Version v2	ok	
Command Class Manufacturer Specific v2	ok	
Command Class Device Reset Locally v1	ok	
Command Class Association v2	ok	
Command Class Association Group Info v1	ok	
Command Class Powerlevel v1	ok	
Command Class Switch Binary v1	ok	
Command Class Switch Multilevel v3	ok	ok
Command Class Switch All v1	ok	
Command Class Configuration v1	ok	
Command Class Node Naming v1	ok	

MANUFACTURER SPECIFIC REPORT

Parameter	Value
Manufacturer ID	0x0085
Product Type ID	0x0007
Product ID	0x0011

 Please note!!! Any repairs to the control system can be performed only by a qualified person and trained by the loft ladder manufacturer.

ADDITIONAL FUNCTIONS

ALL ON / ALL OFF - turning on this function makes it possible to control all devices simultaneously.

 Information on how to define additional functions can be found in user manuals of remote controls.

Z-WAVE DEVICES COMPATIBILITY

The Z-Wave allows to integrate devices of different manufacturers which can work in different groups: lighting, heating, domestic automatic control, etc. The Z-Wave devices operate as repeaters in the network which extends the communication range of radio waves. This product is compatible with other certified Z-Wave devices of other manufacturers. All battery-free devices of different manufacturers operating in one Z-Wave network can route through other devices, which can result in increased range.

 All information on adding devices to the Z-Wave network in controllers offered by other manufacturers can be found in user manuals of these products.

ADVANCED INFORMATION

ASSOCIATION GROUPS

1. Life Line – group for reporting the position of the actuator after each stop and receiving information about the alarm (overload). A maximum of 1 device can be in the group.
2. Basic Repeat – group used for sending received commands of movement (basic set) to devices belonging to this group. A maximum of 5 devices can be in the group.
3. Multilevel Repeat – group used for sending received commands of movement (SWITCH MULTILEVEL SET, SWITCH MULTILEVEL START LEVEL CHANGE, SWITCH MULTILEVEL STOP LEVEL CHANGE) to devices belonging to these groups. A maximum of 5 devices can be in the group.

ADVANCED FUNCTIONS

Function	Description	LED indicator	
		Motor status	Z-Wave network status
Resetting device locally	The Z-Wave device reset without using the Z-Wave controller. The device will be removed from the Z-Wave network, default parameters, names and locations will be restored. Press the programming button P 5 times.	-	On
Resetting parameters locally	The parameter reset without using the Z-Wave controller. Default parameters, names and locations will be restored. Press the programming button P 3 times.	-	Blinking 5 times
Autoinclusion	Adding a hard-to-access device to the Z-Wave network. Each time the power is switched on, the device enters the Autoinclusion mode provided that it is not assigned to the Z-Wave network. The mode is active for up to 10 minutes.	-	Blinking for 10 minutes

WIRING DIAGRAM

Connect the set to network according to the diagram below.

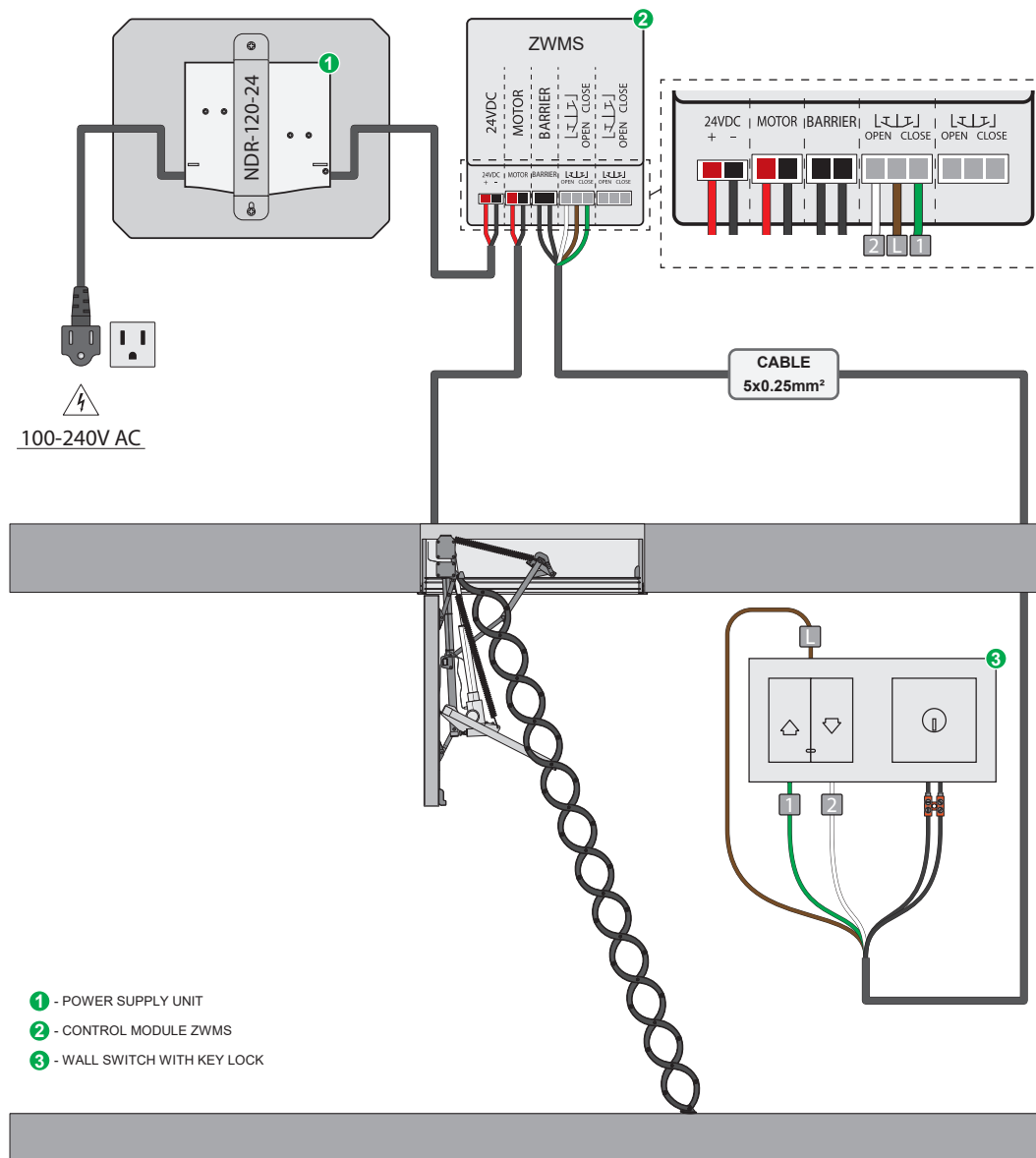

CONTROLLER INSTALLATION

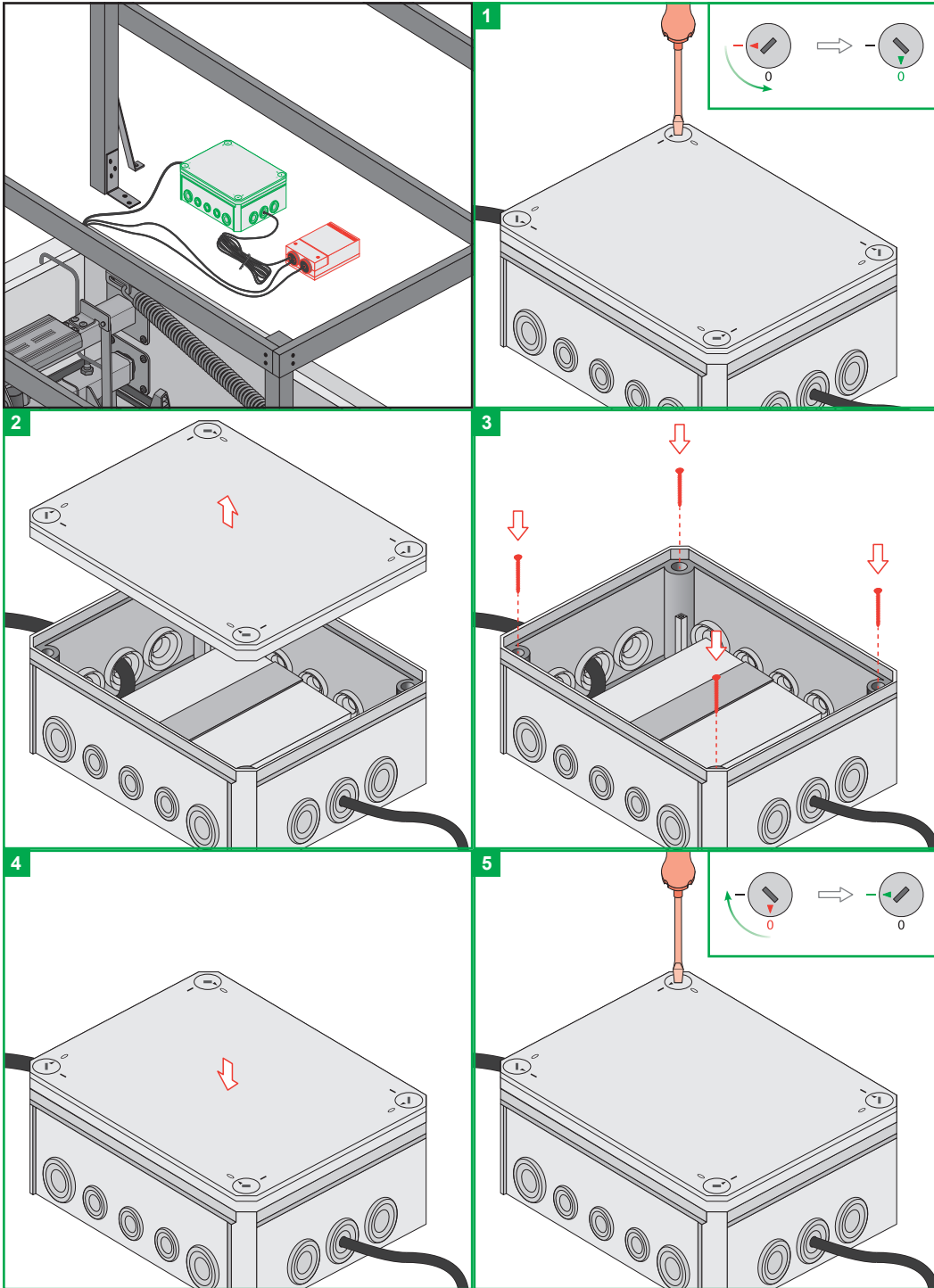

Danger due to people being trapped! People may be locked up in the attic. Failure to free these people may result in serious injury or death.
The emergency unlock must be regularly checked for correct operation from the inside and, if necessary, from the outside as well. Defects must be promptly repaired in a professional manner.



Danger due to moving LET type loft ladder components! When the emergency unlock is activated, the ladder is unlocked and may fall unexpectedly. This may result in serious injuries.
Use extreme caution when folding up / unfolding the LET type loft ladder when using the emergency unlock. No bystanders are allowed in the area of the LET type loft ladder being folded up / unfolded.



The emergency unlock is only intended to open or close the LET type loft ladder in the event of a failure. The emergency unlock function is not intended for regular opening and closing of the loft ladder. This may damage the actuator or the loft ladder. It is not recommended to use the ladder in the emergency mode.



The unlocking function can only be used in emergency situations, eg. a power failure.



During the emergency unlock the LET type loft ladder may unfold on its own or fall unexpectedly quickly due to improper weight balance and performance characteristics of the scissor ladder. The LET type loft ladder structure may be damaged.



The locking and unlocking operation can be performed with the LET type loft ladder open and closed and in any position of the ladder while observing the above safety instructions. Do not run the LET type loft ladder electrically when performing the emergency locking and unlocking operation as this may damage the actuator clutch.

TROUBLESHOOTING

POSSIBLE CAUSE	SOLUTION
1. No option to operate the loft ladder via the ZRHS remote control and the control button.	
No power to the control set.	Check whether the main circuit supplying the control set is switched on. Unlock the loft ladder and open manually according to the instructions provided, if necessary.
The key switch position is set to "off".	Check the position of the switch key and set it to "on".
Break in the switch key circuit.	Check the continuity of the circuit and the correctness of connections.
Break in the actuator circuit.	Check the continuity of the circuit and the correctness of connections.
2. No option to operate the loft ladder via the ZRHS remote control. The control button works properly.	
No radio coverage	Check whether the remote control works from a closer distance.
The remote control has dead batteries.	Replace batteries in the remote control.
The remote control displays "0" and is unprogrammed.	Program the remote control again according to the manual on channel 1.
3. No option to operate the loft ladder via the control button. The ZRHS remote control works properly.	
The control button is plugged incorrectly or there is a break in the switch circuit.	Check the connection of the control button according to the diagram in the manual.
4. The loft ladder stops at an intermediate position and does not reach the fully open or closed position.	
Overload protection blocks the loft ladder from closing.	Remove the obstacle from the loft ladder blocking the closure.
The set overload limit of the controller is too low.	Consultation with the manufacturer's service dept. is required to set the correct limit.
5. When starting the loft ladder, the "SS" message is displayed on the remote control.	
The service counter of open/close cycles has exceeded the value of 400. The loft ladder should be inspected by the service.	Have the product inspected by qualified personnel. Reset the service counter using the included remote control by changing the value of the "91" parameter (see Z-Wave configuration parameters and remote control manual).

EMERGENCY UNLOCK

In the event of a power outage, the LET type loft ladder can be manually opened and closed using a mechanical emergency unlock. In connection with the operations described in this chapter, observe the following safety instructions in particular.

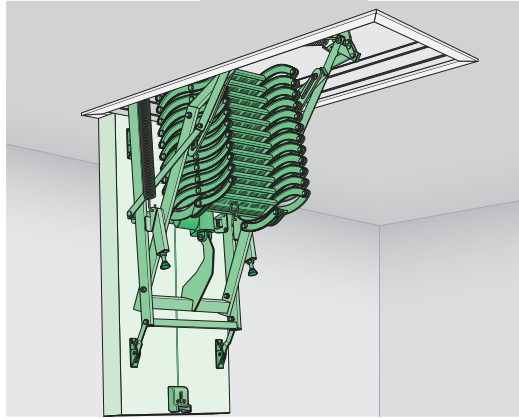
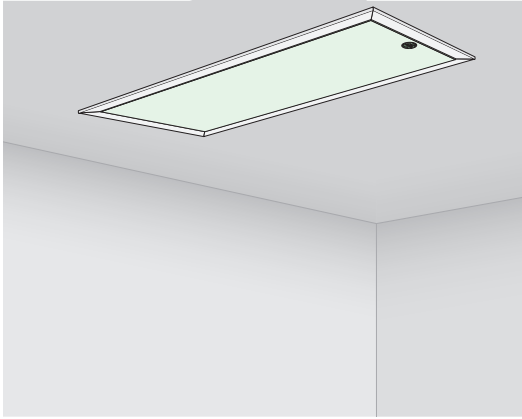

UNLOCKING

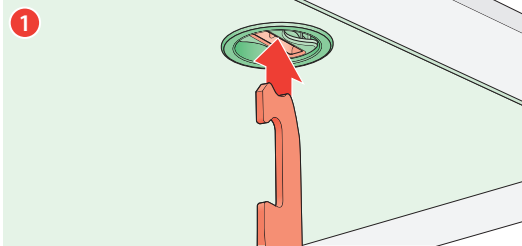

Place the tip of the rod in the catch recess on the hatch.

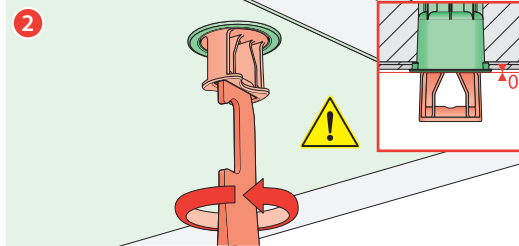

Turn to the left until the catch element is flush with the hatch plane (diagram). This operation can also be performed manually, without using a rod. The actuator is unlocked. The LET type loft ladder can be unfolded and folded up manually.

 Further unscrewing of the catch may result in damage to the set.

LOCKING

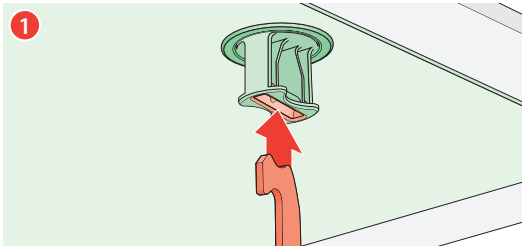

Place the tip of the rod in the catch recess on the hatch.

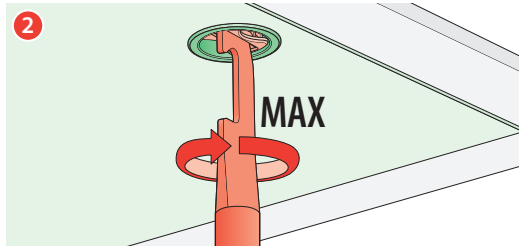

Turn to the right until fully screwed in. This operation can also be performed manually, without using a rod. The actuator is locked. The LET type loft ladder can be unfolded and folded up electrically.

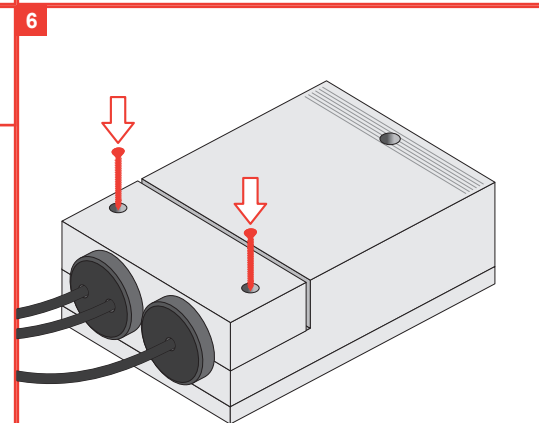
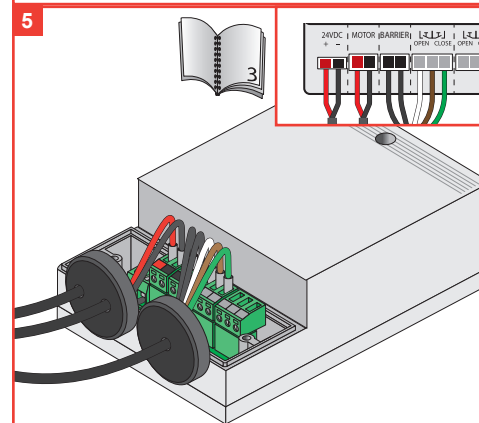
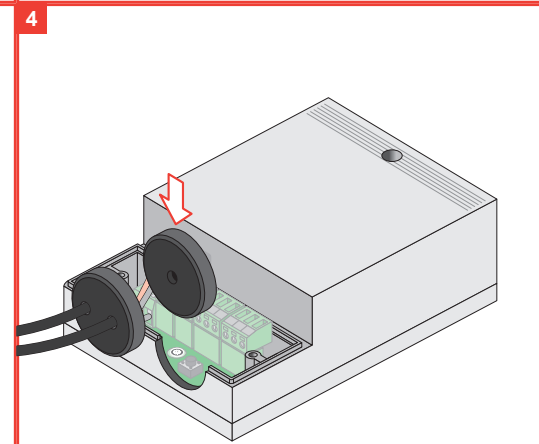
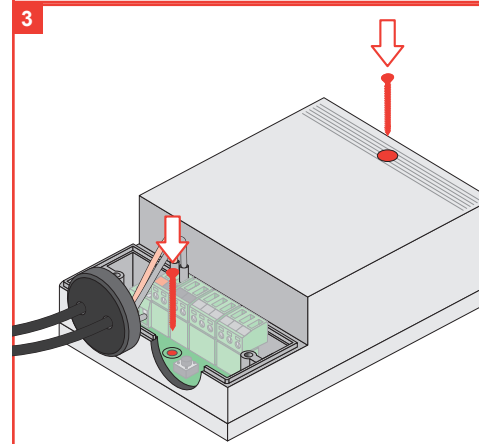
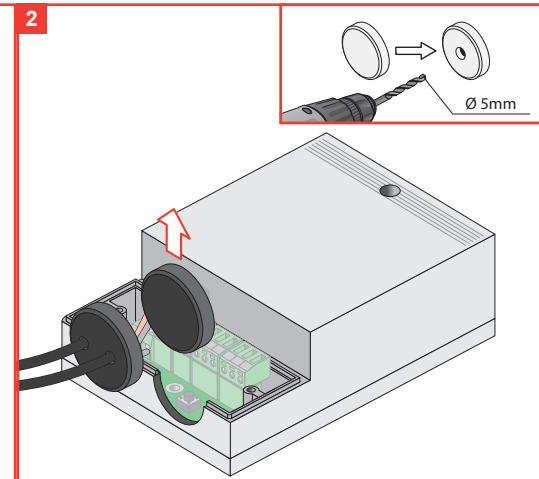
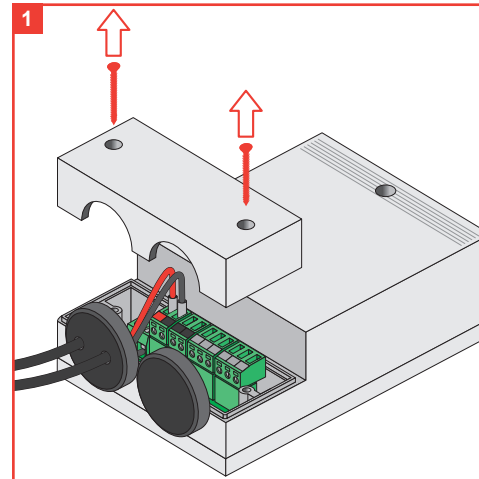

PROGRAMMING

The type LET loft ladder is factory programmed to the remote control. In case of control problems, add the type LET loft ladder to the Z-Wave network again. For programming information refer to the user manual of the ZRHS remote control.

ADD TO NETWORK
ADD TO GROUP
REMOVE FROM NETWORK
REMOVE FROM GROUP
etc.

Run selected function on the Z-Wave controller.

METHOD 1

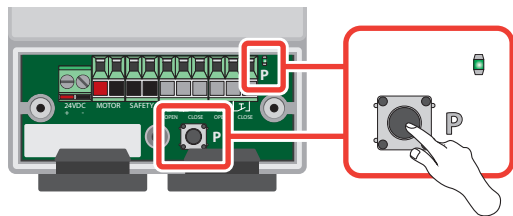

Enter the LET type loft ladder into the programming mode by pressing the P button.

METHOD 2*

OFF / ON

Reset the LET type loft ladder power supply.

i *It allows a hard-to-access LET type loft ladder to be remotely added to the Z-Wave network without the need for pressing the programming button. Each time the power is switched on, the LET type loft ladder enters the Autoinclusion mode provided that it is not assigned to the Z-Wave network. The mode is active for up to 10 minutes.

LOFT LADDER LOCK

It is recommended to install a wall lock with a key to prevent unauthorised or accidental use of the loft ladder. The use of a key lock in the wall switch prevents accidental activation of the loft ladder and use by children or unauthorised persons.

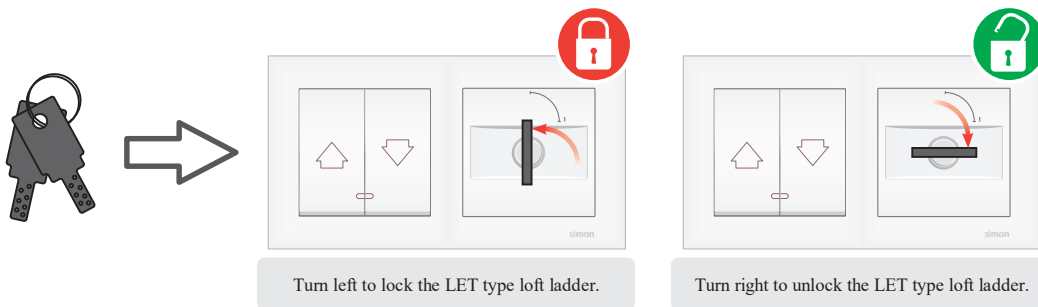

DECLARATION OF CONFORMITY

CE FAKRO Sp. z o.o. hereby declares that a type of radio device LET complies with the RED Directive 2014/53/EU. The full text of the EU Declaration of Conformity can be found at: <https://www.fakro.com/ce-declarations/search/>

COMPLIANCE WITH THE WEEE DIRECTIVE



Devices marked with this symbol must not be disposed of or thrown away as household waste. It is the user's responsibility to deliver devices that are worn out to the designated recycling area.

CONTROL

MANUAL CONTROL

! Caution!!! Before running, separate a protective zone under the LET type loft ladder.

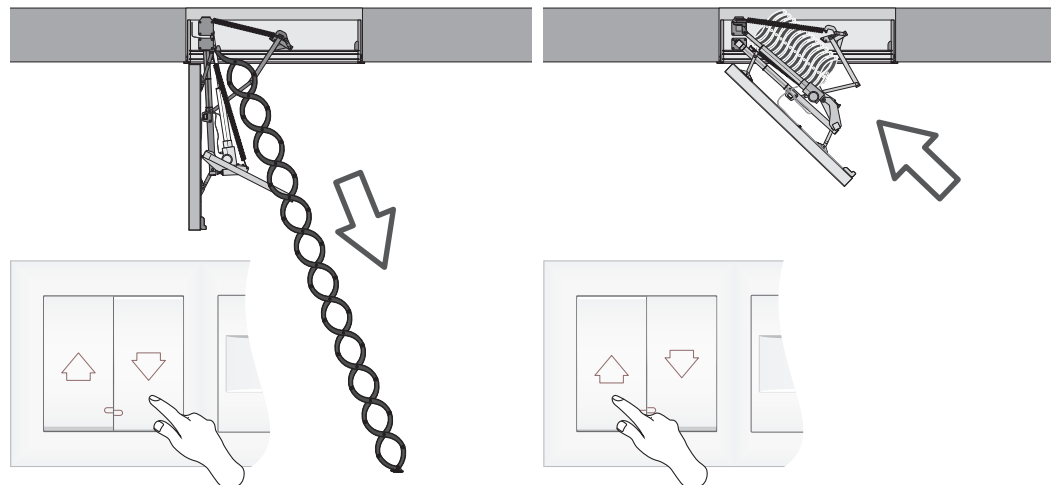

Hold the "DOWN" button to open the LET type loft ladder.

Hold the "UP" button to close the LET type loft ladder.

CONTROL VIA ZRHS REMOTE CONTROL

! Caution!!! Before running, separate a protective zone under the LET type loft ladder.

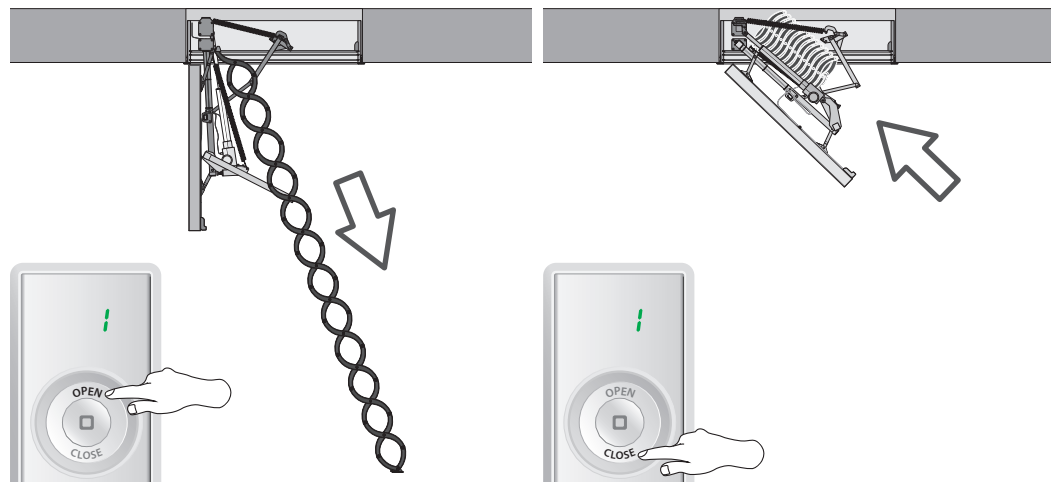

Press the "OPEN" button to open the LET type loft ladder.

Press the "CLOSE" button to close the LET type loft ladder.

Press the middle button to stop the LET type loft ladder.