

LTA R5 LTT R10

US

INSTALLATION INSTRUCTIONS
Attic ladder

ES

INSTRUCCIONES DE INSTALACIÓN
Escaleras escamoteables

FR

INSTRUCTION D'INSTALLATION
Escalier escamotable

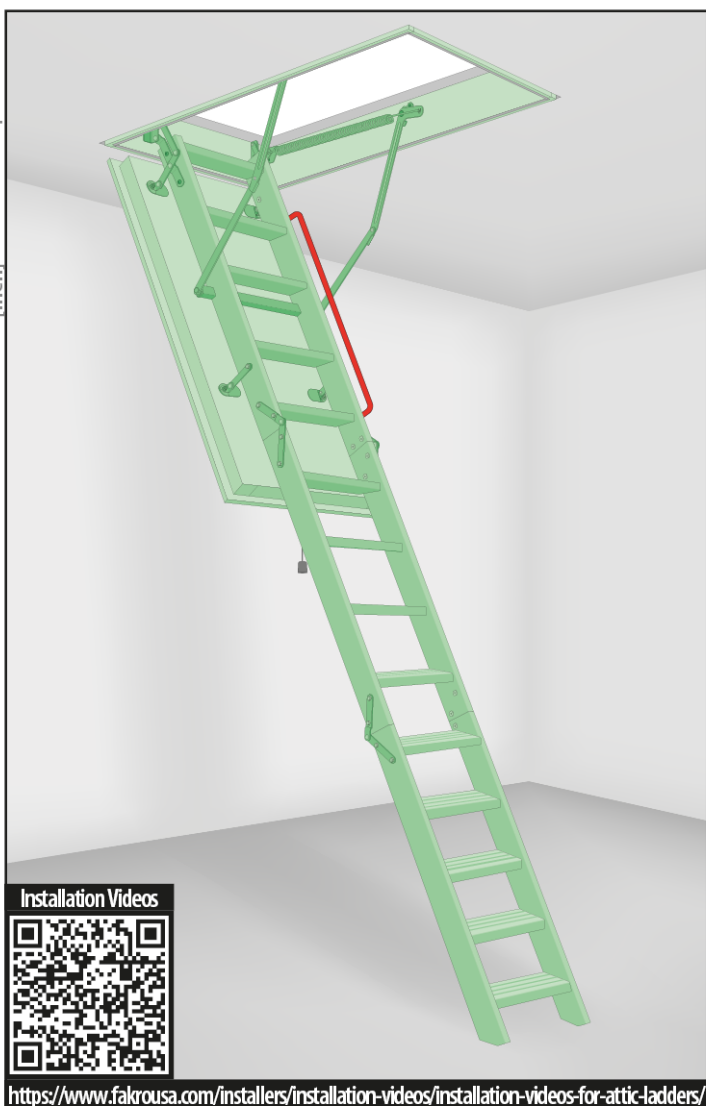

READ SAFETY INSTRUCTION BEFORE USING

WARNING!
ATTENTION!
CUIDADO!



NC 9CE

ES LEA LAS INSTRUCCIONES DE SEGURIDAD ANTES DE USAR

FR VEUILLEZ LIRE LES DIRECTIVES DE SÉCURITÉ AVANT L'UTILISATION

US

Installation and operation of the attic ladder must be carried out in compliance with the installation instructions and user manual. Safety of use depends on the implementation of all actions shown in the installation instructions and use of the attic ladder in accordance with all points shown in the user manual. **WARNING!** Using the attic ladder in violation of the instructions is strictly forbidden as it may cause a serious accident, it voids the Warranty and makes the Manufacturer no longer liable for the product.

ES

El montaje y el uso de la escalera debe llevarse a cabo de acuerdo con el manual de instalación y el manual de uso de la misma. La seguridad de uso de la escalera depende de la correcta realización de todas las acciones indicadas en el manual de instalación y uso de la escalera de acuerdo con todos los puntos indicados en el manual de uso. **¡PRECAUCIÓN!** Está prohibida la utilización de la escalera que no sea conforme con el manual de instrucciones, porque puede causar un accidente grave, deshabilita la garantía y hace que el fabricante no se responsabilice.

FR

Le montage et l'utilisation de l'escalier doivent être réalisés dans le respect de l'instruction de montage et d'utilisation. La sécurité d'utilisation dépend de la réalisation de toutes les activités indiquées dans l'instruction de montage et d'utilisation de l'escalier. **ATTENTION!** l'utilisation des escaliers contrairement à l'instruction est interdite, elle peut provoquer un accident grave, annulation de la garantie et manque de responsabilité du fabricant.

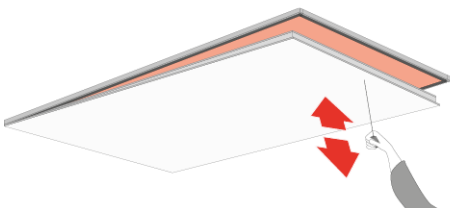

US Check the clearance behind your opening

ES Verifique el espacio detrás de su abertura

FR Vérifiez l'espace derrière votre ouverture

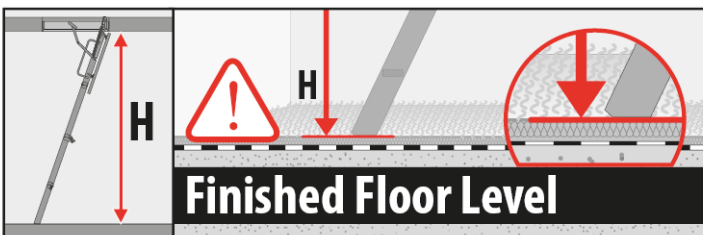
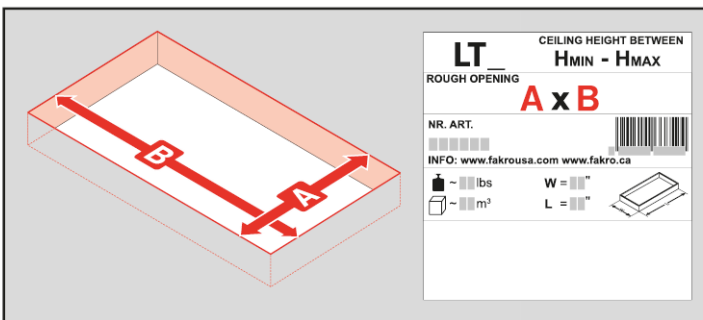
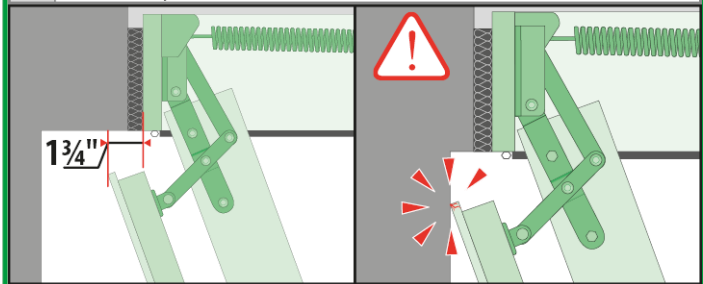

H max

H min

10'4"

7'11"

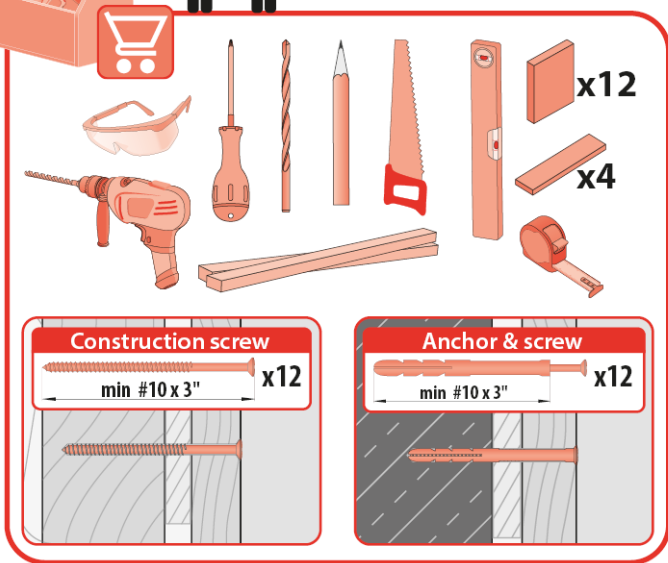

US	Two installation methods:
ES	Dos métodos de instalación:
FR	Deux méthodes d'installation:



1 Most common

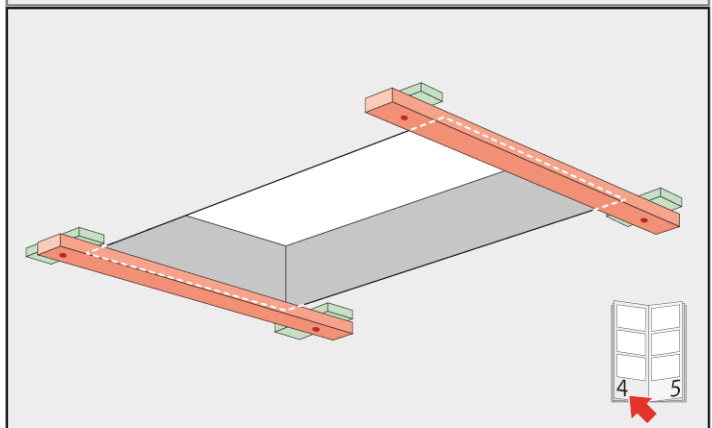

2 Requires additional accessory LXX EXTRA BUY

US	2) temporary installation brackets - check floor cross section requirements
ES	2) soportes de instalación temporal: verifique los requisitos de sección transversal del piso
FR	2) fixations d'installation temporaire - veuillez consulter les exigences concernant la coupe transversale du plancher

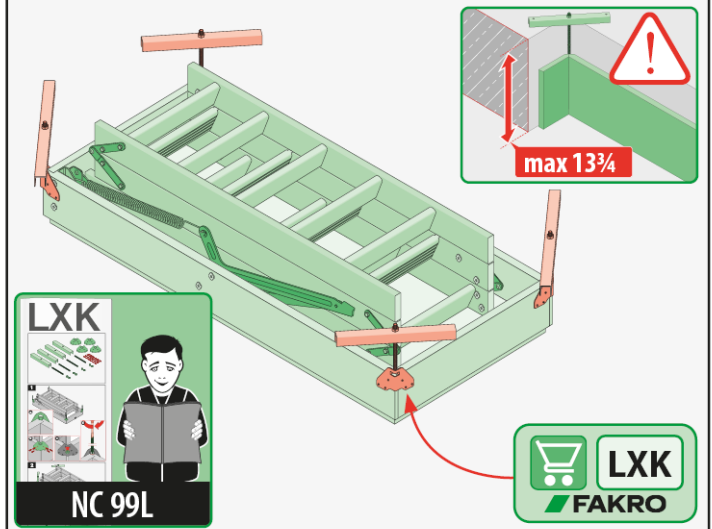

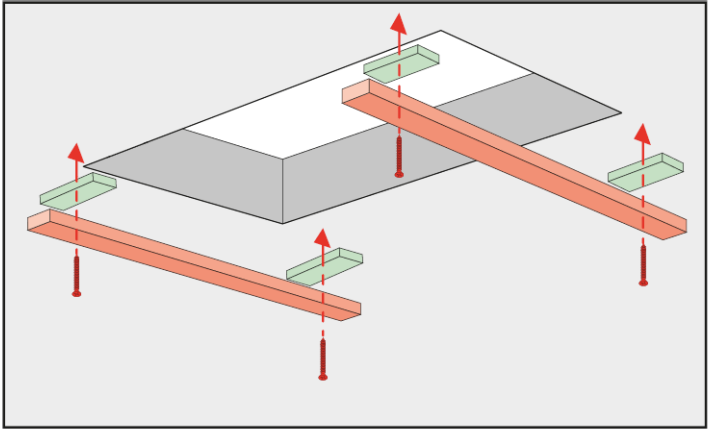
1**Installation with temporary support boards**

US Use a distance block 'T' to level ladder frame with a ceiling drywall.

ES Utilice un taco distanciador en forma de 'T' para nivelar el marco de la escalera con un panel de yeso de los del techo

FR Utilisez le bloc d'espacement en « T » pour aligner le cadre de l'escalier avec les cloisons sèches au plafond

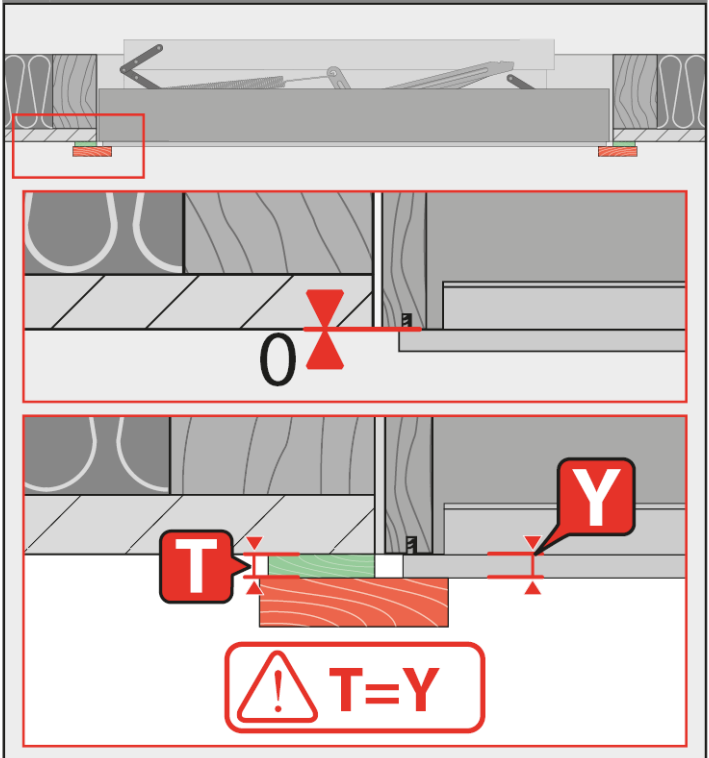
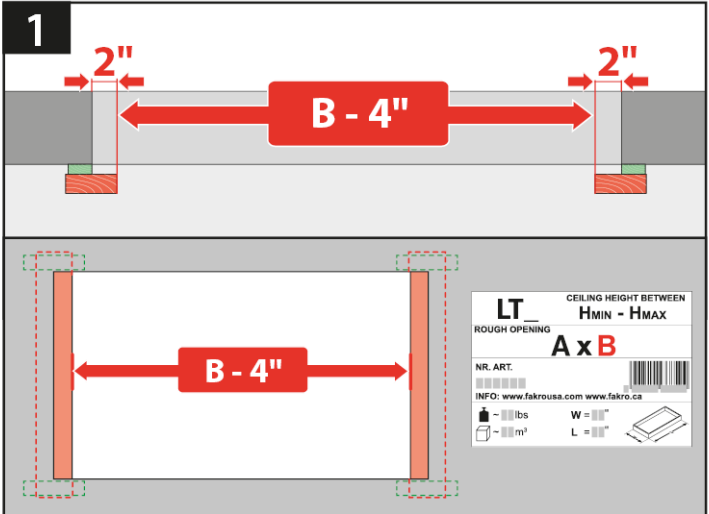
**1**

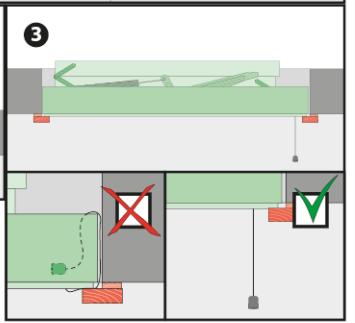
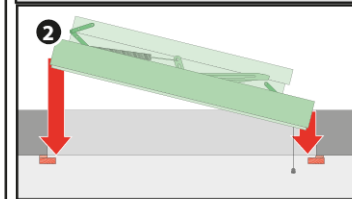
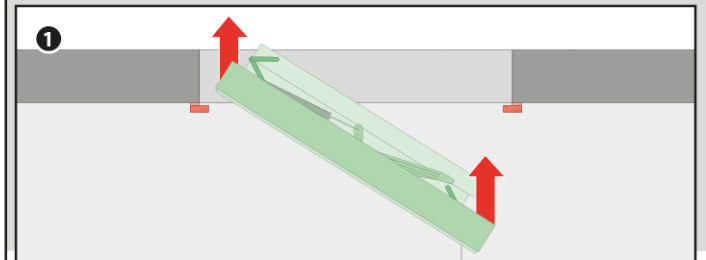
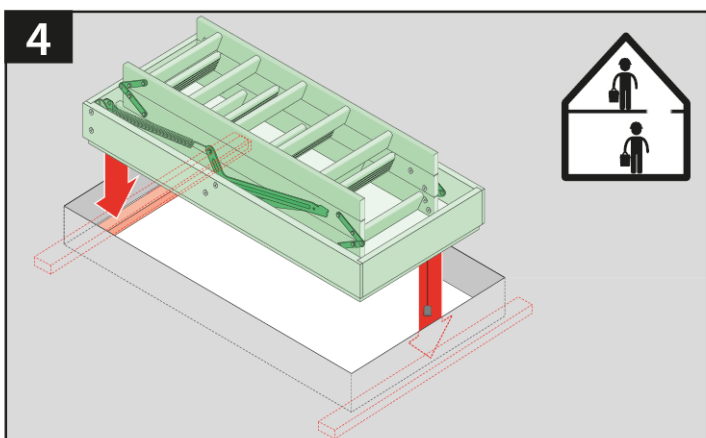
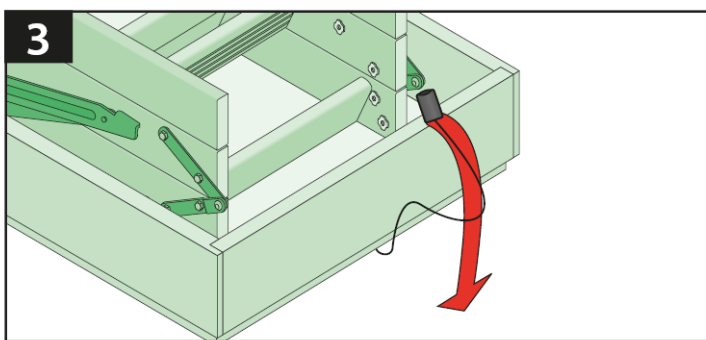
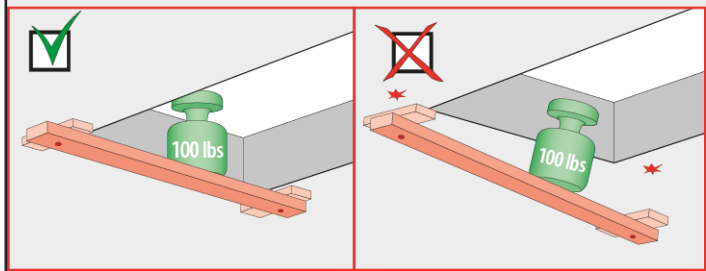
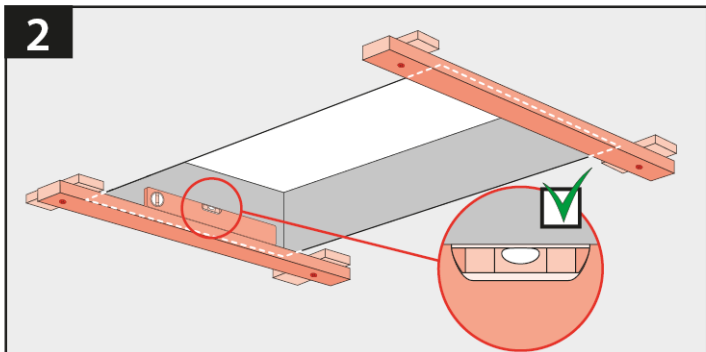

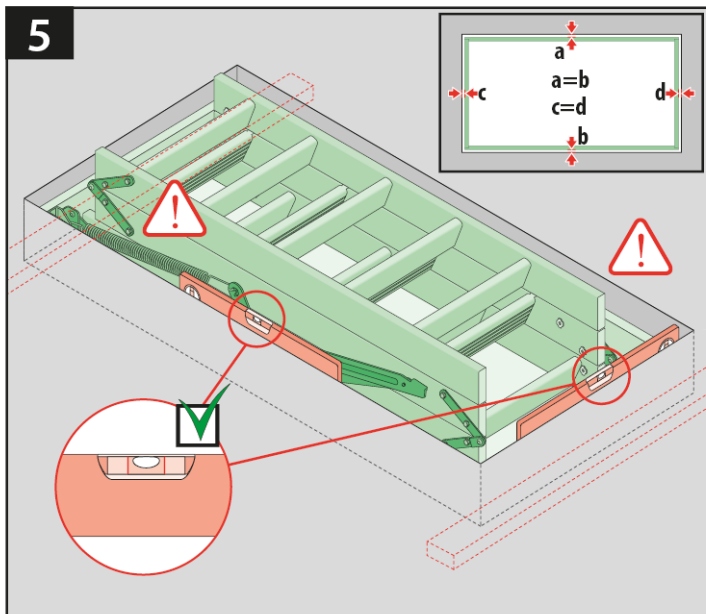

US	Lift two ladder sections to install first installation screws
ES	Levante dos segmentos de la escalera para instalar los primeros tornillos de instalación
FR	Soulevez les deux sections de l'escalier pour installer les premières vis de montage

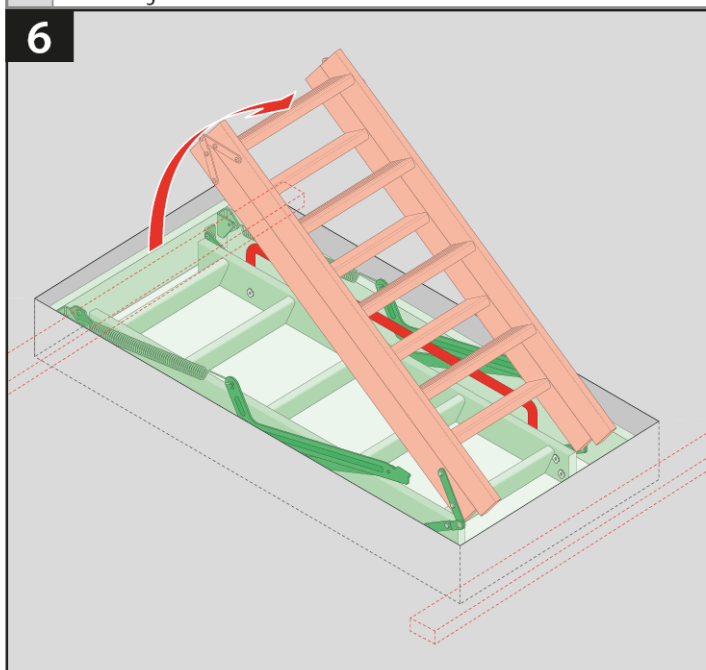

US	Use shims with all installation screws to prevent frame bowing
ES	Utilice arandelas con todos los tornillos de instalación para evitar que el marco se doble
FR	Utilisez des rondelles pour toutes les vis de montage afin d'éviter que le cadre ne se plie

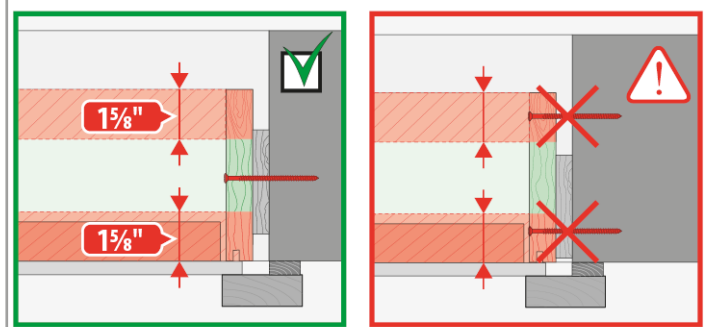

7

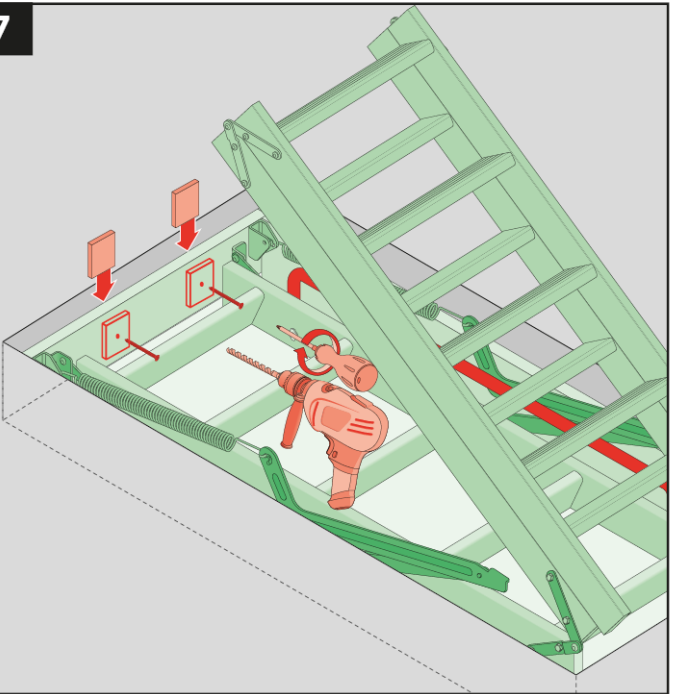

US Narrow space may require bit extension

ES Los espacios estrechos pueden requerir una extensión de broca

FR L'espace étroit peut nécessiter une extension de l'embout

8

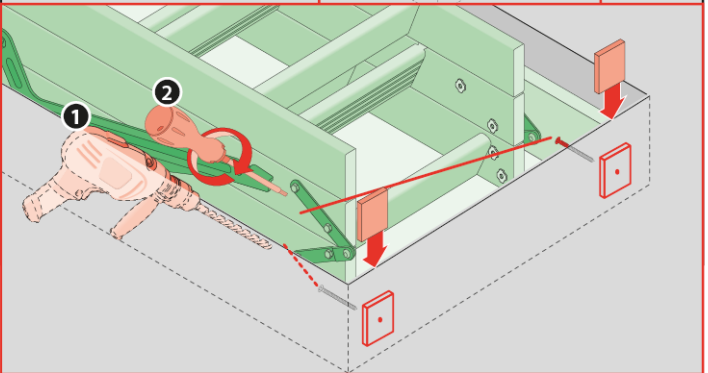
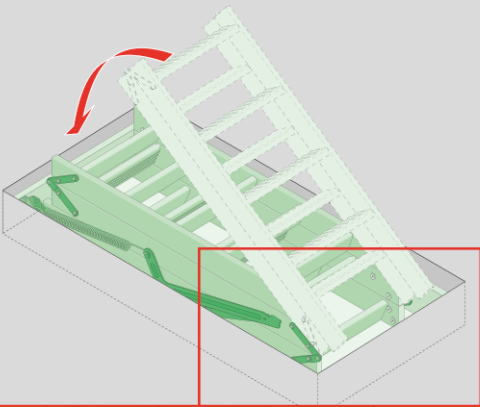

US Check diagonals and adjust installation screws if necessary

ES Compruebe las diagonales y ajuste los tornillos de instalación si es necesario

FR Vérifiez les diagonales et ajustez les vis de montage si nécessaire

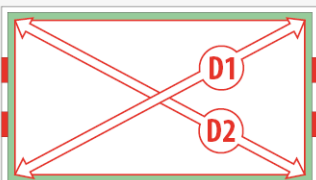

D1=D2



US	Remove temporary support to open ladder door
ES	Retire el soporte temporal para abrir la puerta de la escalera
FR	Retirez le support temporaire pour ouvrir la trappe d'escalier

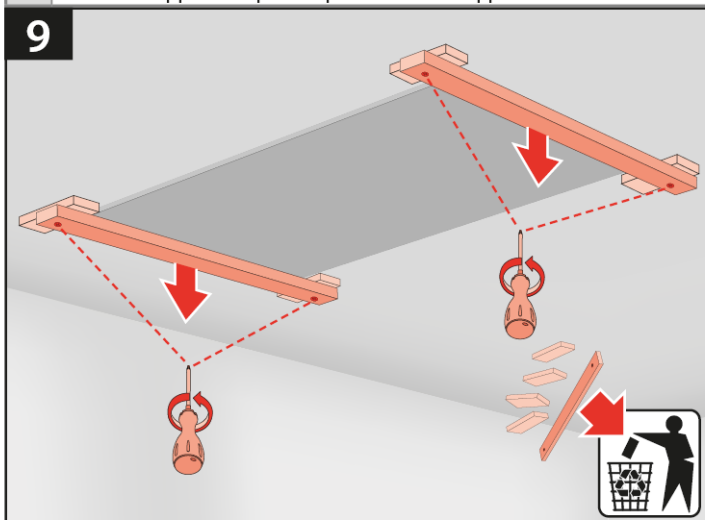

US	The attic ladder must not be used unless they are completely anchored in accordance with this instruction
ES	Las escaleras no deben usarse a menos que estén totalmente ancladas al techo de acuerdo con las instrucciones
FR	L'échelle ne doit être utilisée que si elle est complètement ancrée au plafond conformément aux instructions indiquées ci-dessous

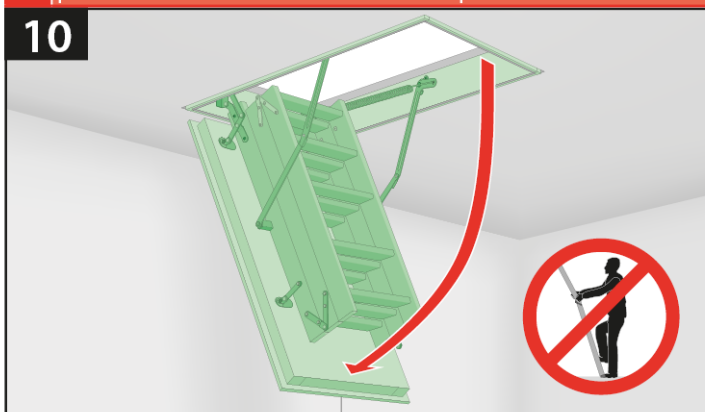

US	Install all remaining installation screws
ES	Instale todos los tornillos de instalación restantes
FR	Installez toutes les vis de montage restantes

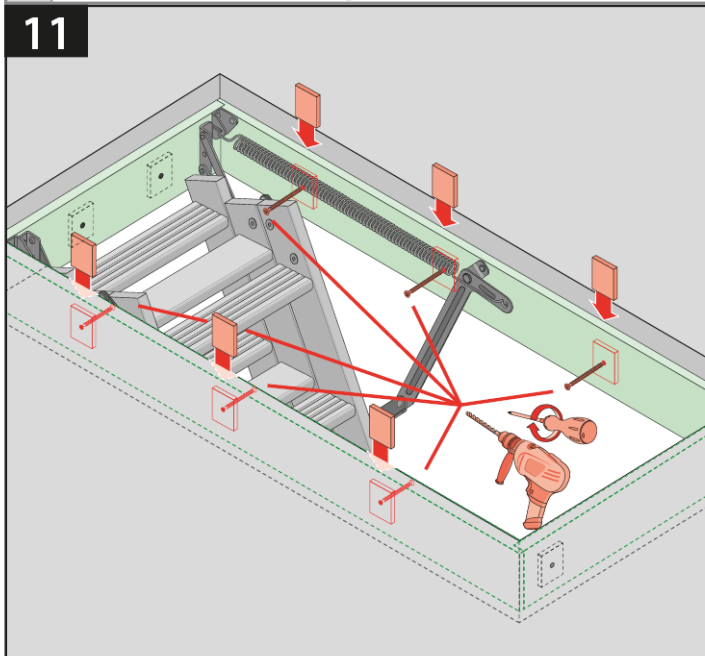

12

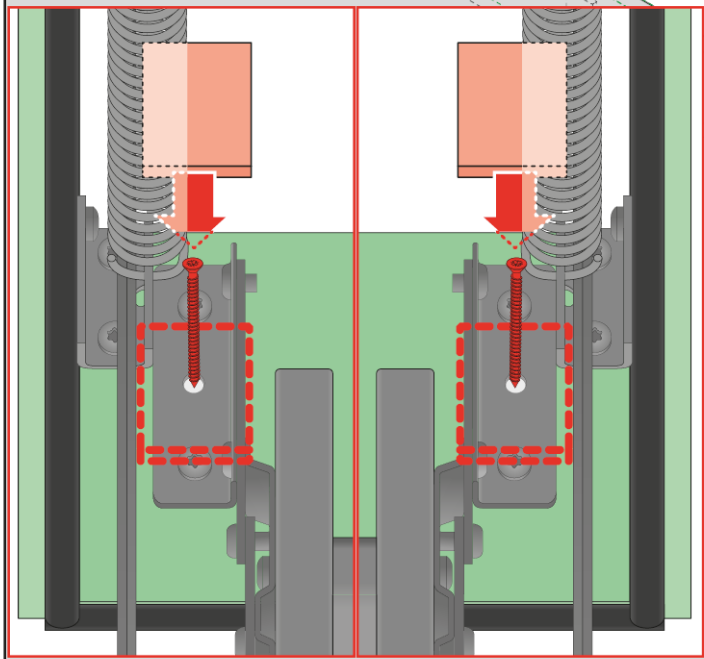
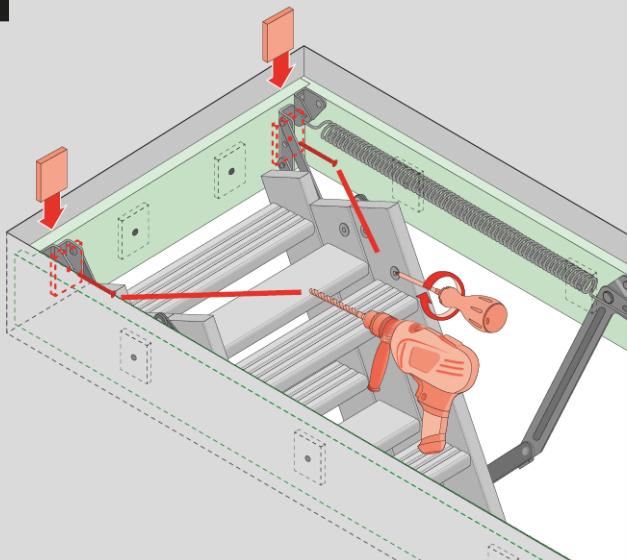

US	Check diagonals and adjust installation screws if necessary
ES	Compruebe las diagonales y ajuste los tornillos de instalación si es necesario
FR	Vérifiez les diagonales et ajustez les vis de montage si nécessaire

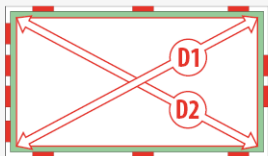

D1=D2 ✓



US	Carefully unfold the ladder while bending the last section to the back as shown on step 14
ES	Despliegue con cuidado la escalera mientras dobla el último segmento hacia atrás como se muestra en el paso 14
FR	Dépliez soigneusement l'échelle du grenier tout en dépliant la dernière section vers l'arrière, comme indiqué à l'étape 14

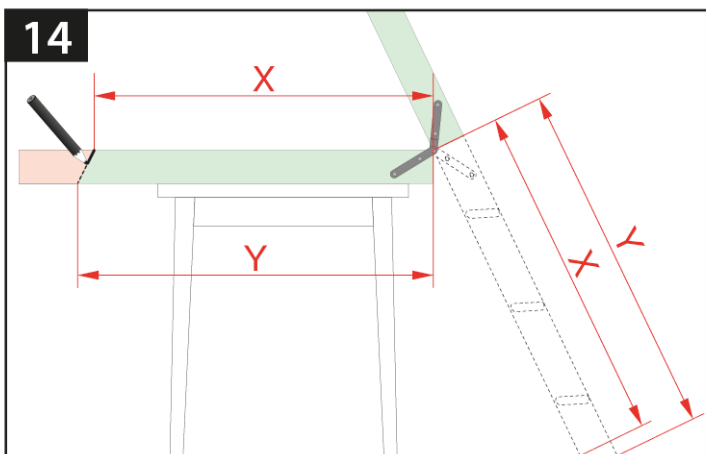
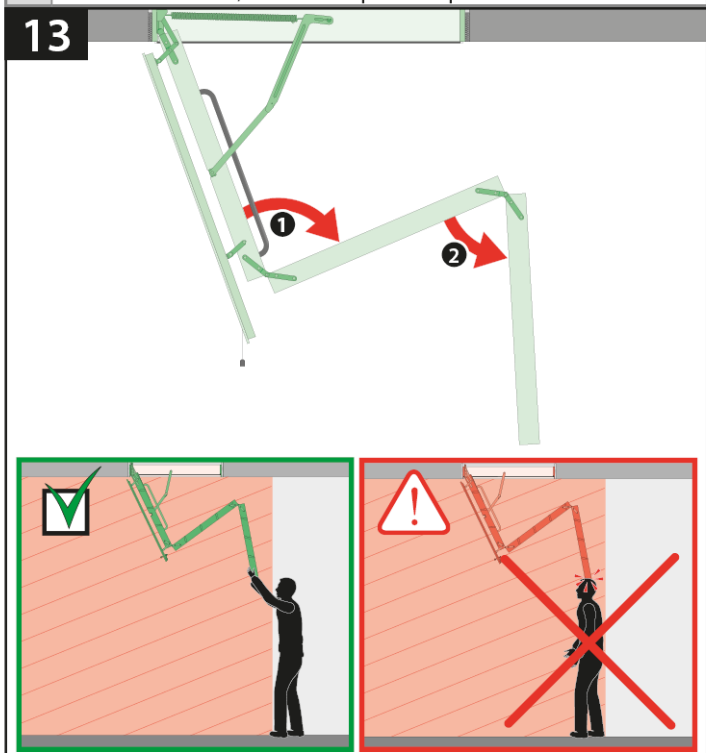

US	Measure required distance to the finished floor. Transfer the measurements onto last ladder section as shown above.
ES	Mida la distancia necesaria hasta el piso terminado. Transfiera las medidas al último segmento de la escalera como se muestra arriba.
FR	Mesurez la distance requise par rapport au sol fini. Transférez les mesures à la dernière section de l'échelle de grenier comme indiqué ci-dessus.

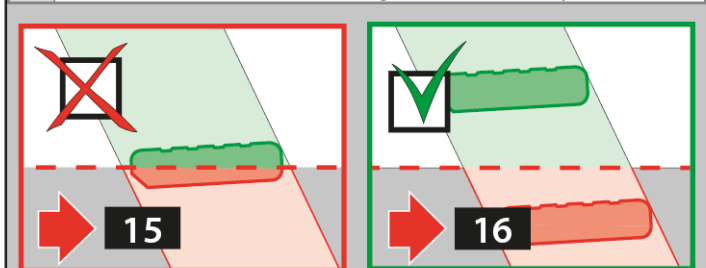

US	In case when cut line aligns with ladder step, remove that step - as shown in section 15
ES	En caso de que la línea de corte se alinee con el escalón de la escalera, retire ese escalón, como se muestra en la sección 15
FR	Si la ligne de coupe coïncide avec la marche de l'escalier, retirez la marche de l'escalier - comme indiqué à la section 15

15

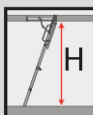

H

10'4"

H_{min}

7'11"



1

2



3



16

US Last ladder section should have minimum two steps left after cut

ES El último segmento de la escalera debe tener al menos dos escalones restantes después del corte.

FR La dernière section de l'escalier doit comporter au moins deux marches lorsqu'elle est coupée



min 2x



16

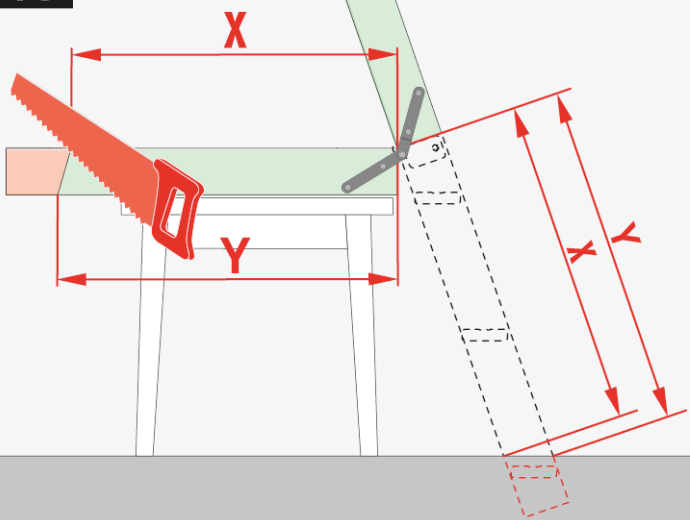

1

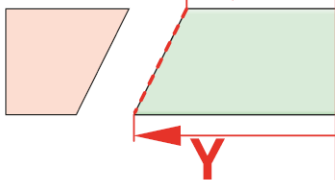

2

$\frac{3}{8}$ "

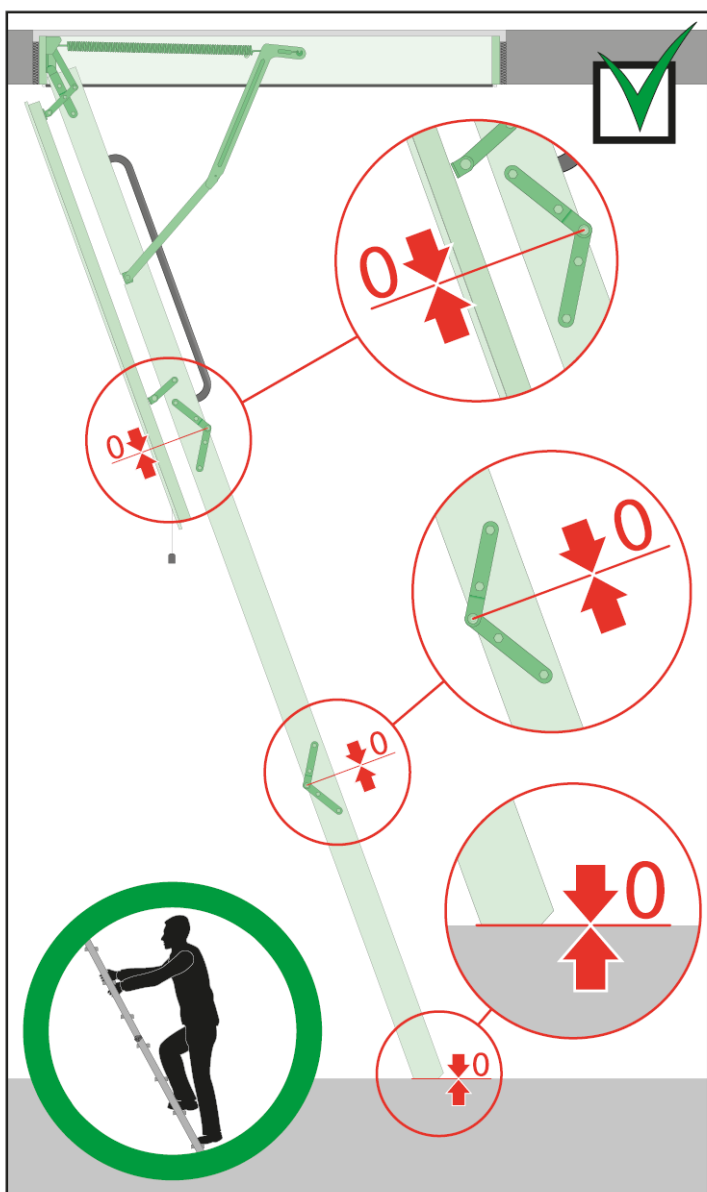

17



THERMO INSULATION

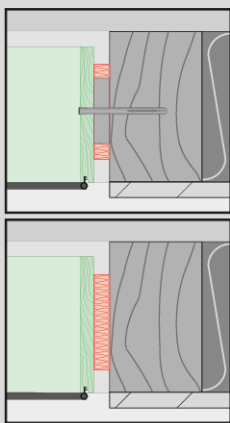
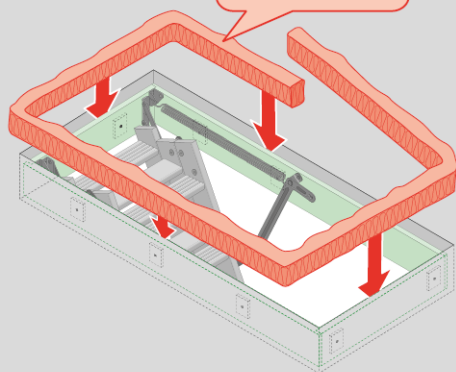

WARNING!

US The bottom section must flush with the floor. Failure to proper adjustment of the ladder could result in unnecessary stress on the component parts, resulting in serious injury.

ES La sección inferior debe estar a ras del piso. Si no se ajustan correctamente los pies de la escalera podría producirse un esfuerzo innecesario en los componentes, y esto puede resultar en lesiones graves.

FR La section du bas doit arcehvêtrer pile au plancher. Un réglage incorrect des pieds de l'échelle peut générer des contraintes superflues sur les pièces, pouvant entraîner une blessure grave.

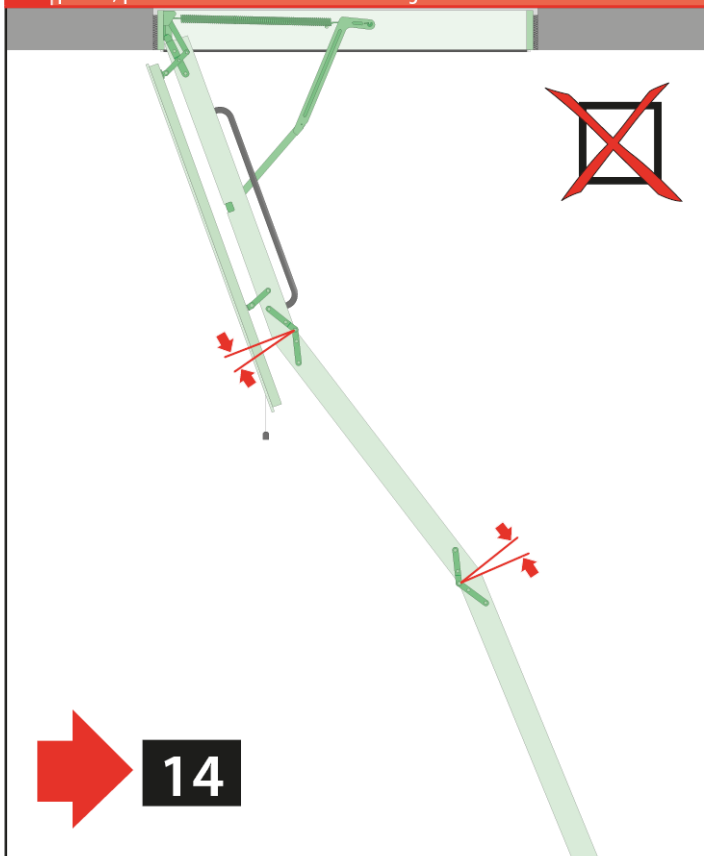

14



US If the ladder is too long go back to step 14

ES Si la escalera es demasiado larga, vuelva al paso 14

FR Si l'échelle est trop longue, revenez à l'étape 14

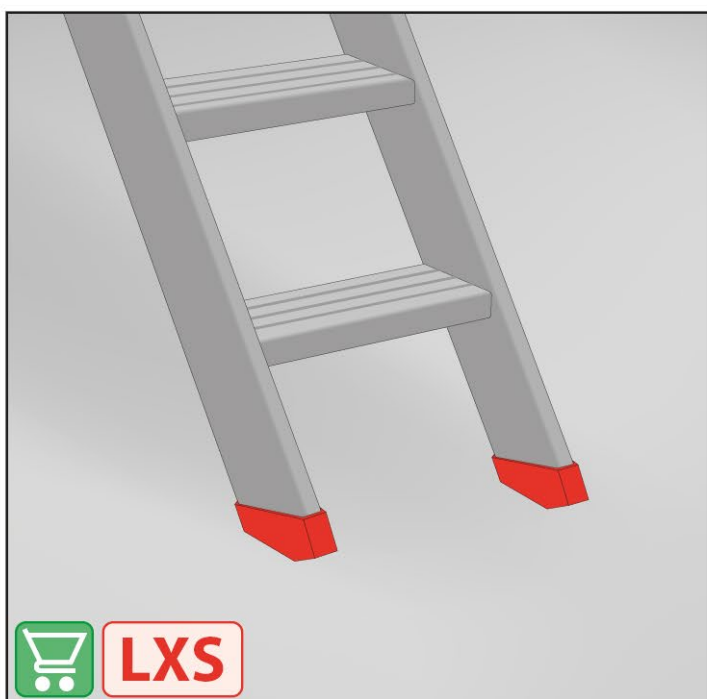

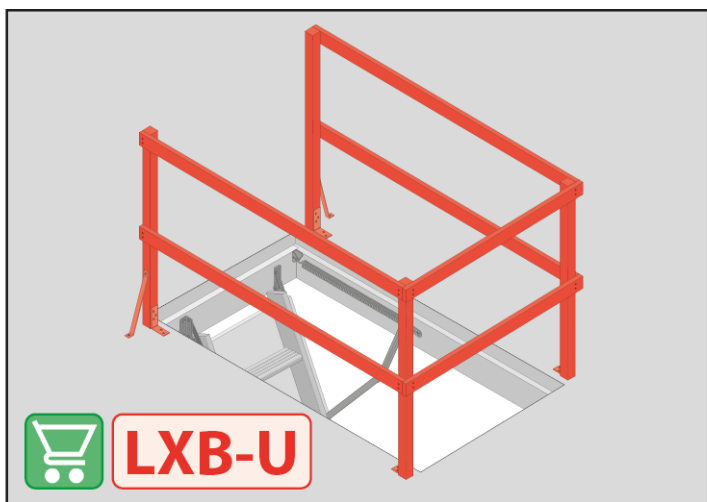
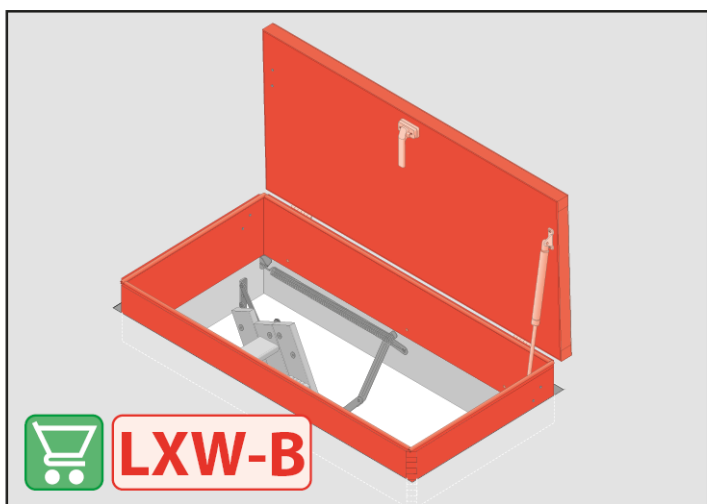
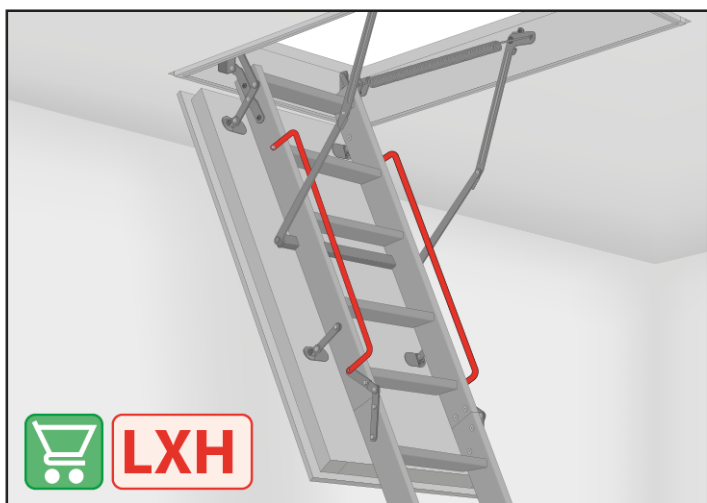
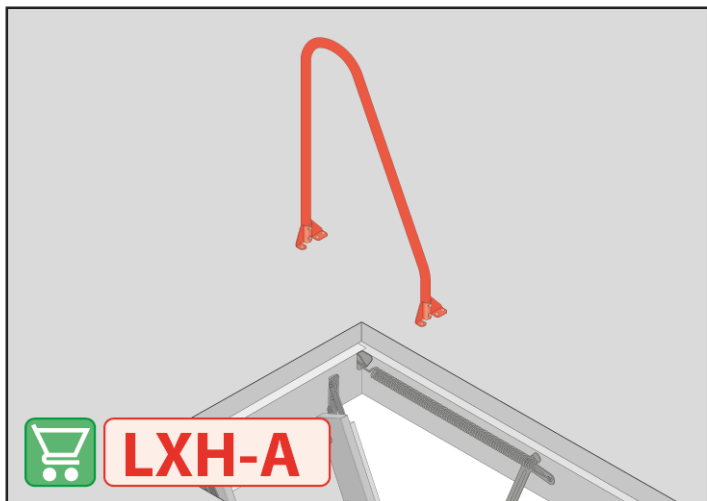

! WARNING! - ATTENTION! - CUIDADO! SAFETY & MAINTENANCE

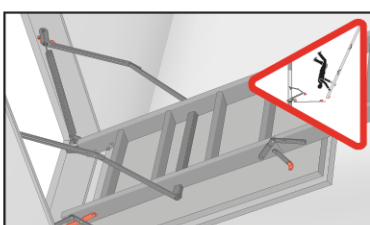
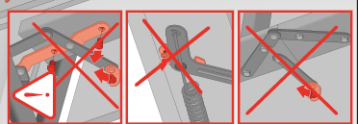
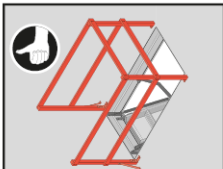
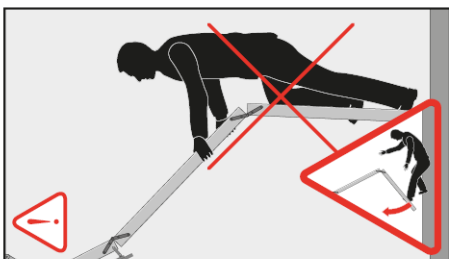
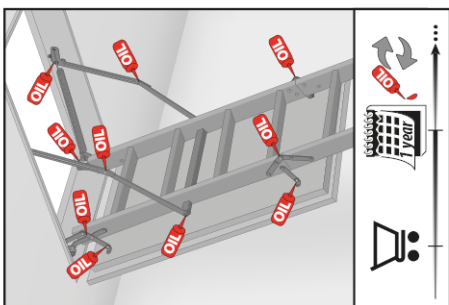
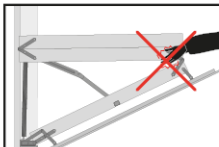
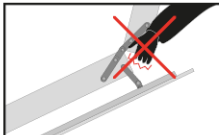
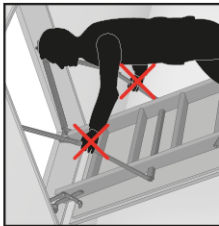

SAFETY! - SÉCURITÉ! - SEGURIDAD!
<https://www.fakrousa.com/safety-instructions/>



FAKRO
www.fakrousa.com, www.fakro.ca

(inchi)
 1
 2
 3
 4
 5

US

Manufacturer and Seller shall bear no liability for failure to comply with the applicable laws, building codes and safety requirements by the user of the product, architect, fitter or owner of the building.

ES

El fabricante y el vendedor no tienen ninguna responsabilidad por el incumplimiento de la ley vigente, normas de construcción y exigencias de seguridad por parte del usuario del producto, arquitecto, instalador o el propietario del edificio.

FR

Le fabricant et le revendeur ne prend aucune responsabilité de ne pas respecter les lois applicables, les règlements sur les bâtiments et les exigences de sécurité par l'utilisateur du produit, l'architecte, l'installateur ou le propriétaire du bâtiment.