

FNP

20
19
18
17
16
15
14
13
12
11
10
9
8
7
6
5
4
3
2
1
0 [cm]

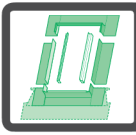

15°-90°

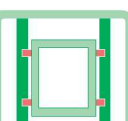
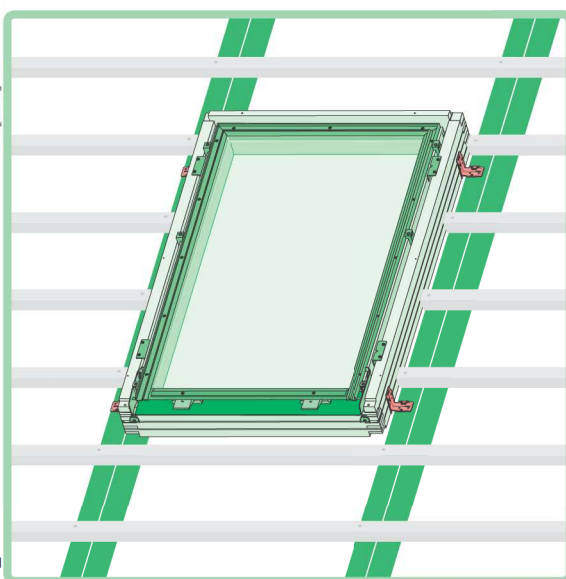
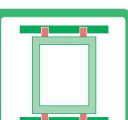
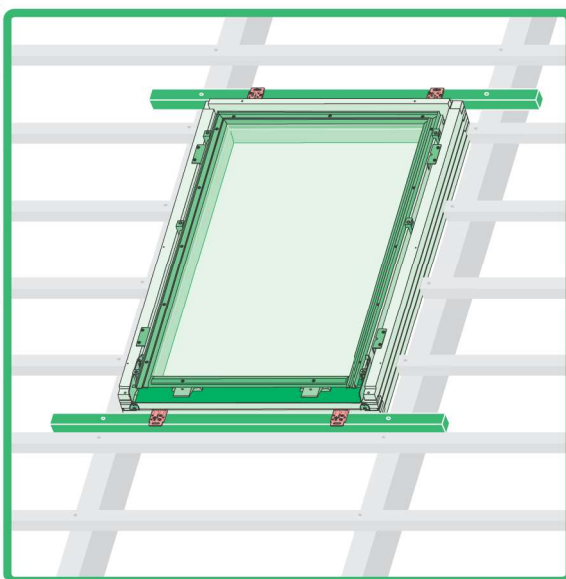
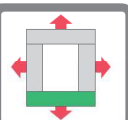

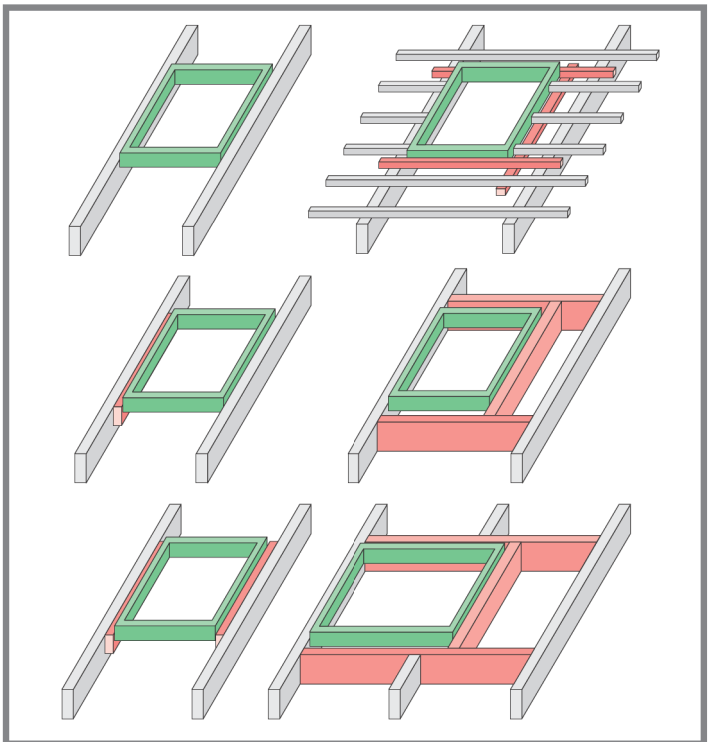
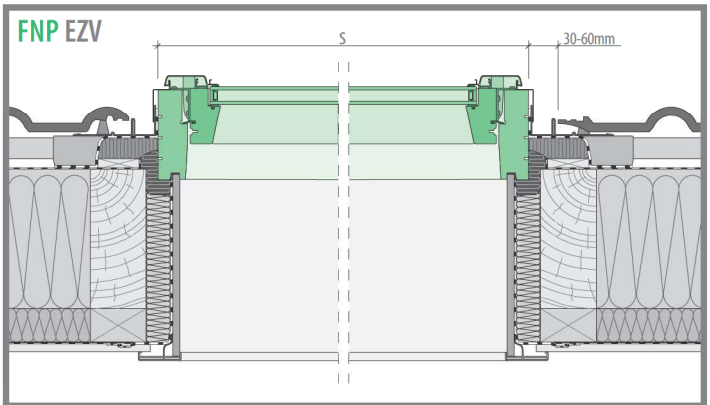
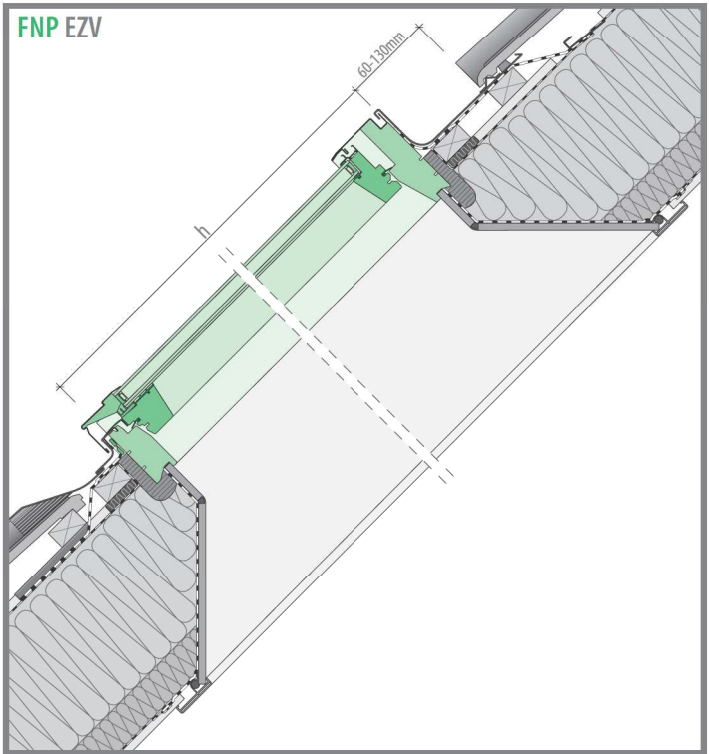
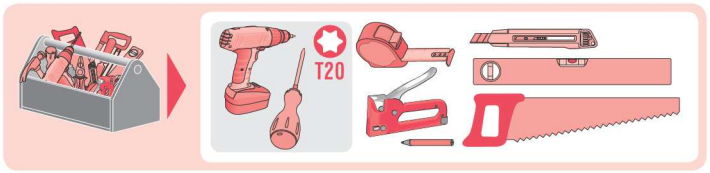



1

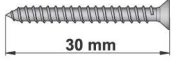
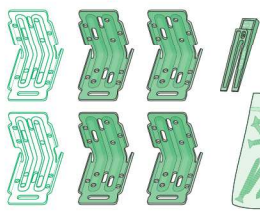
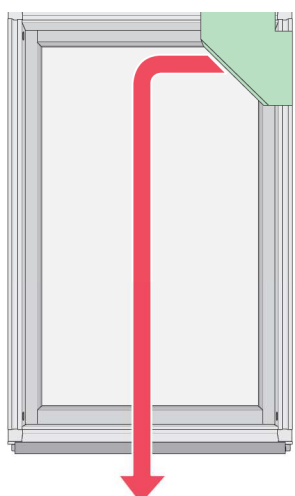

30 mm

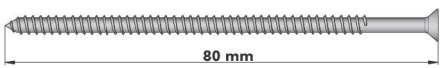

80 mm

2

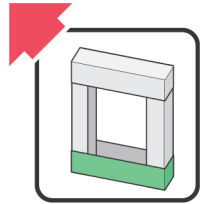
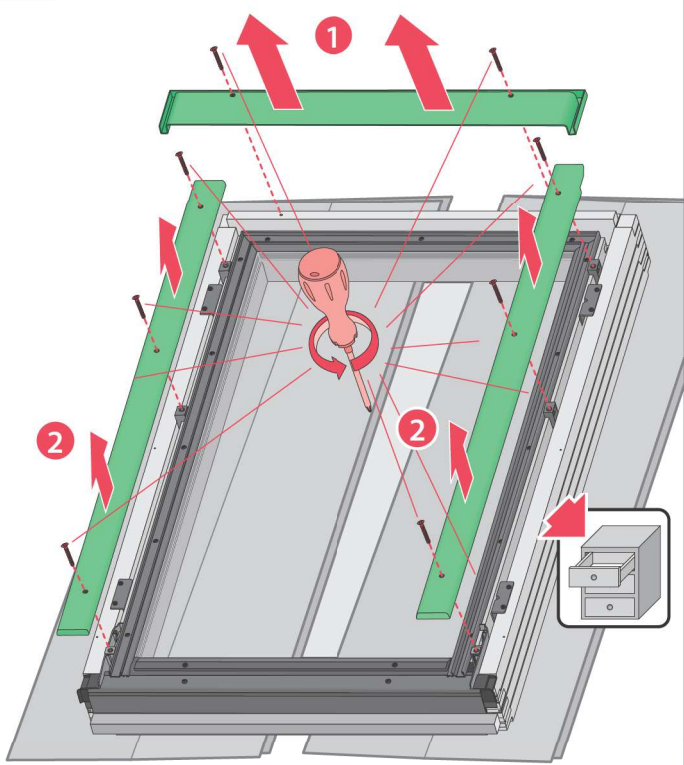

3

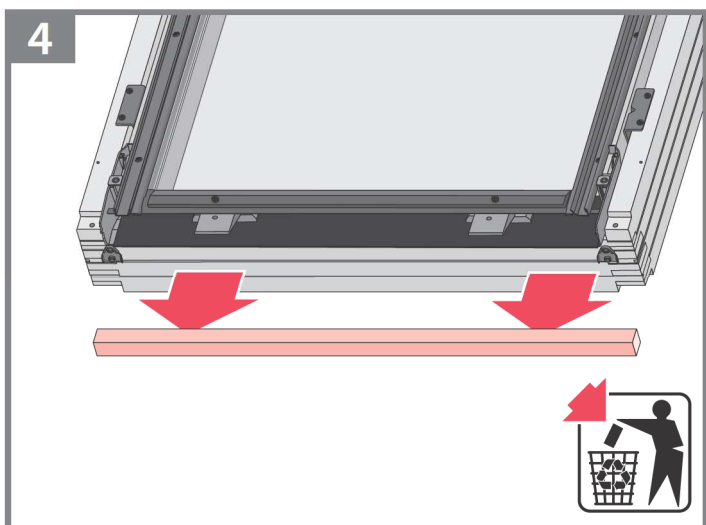
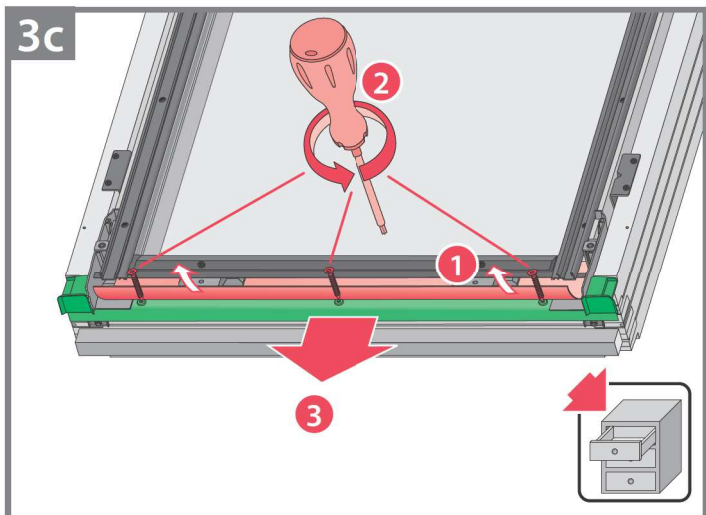
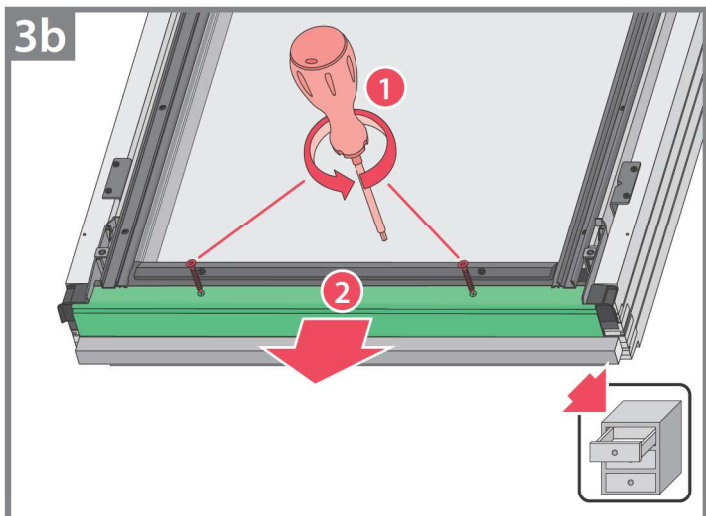
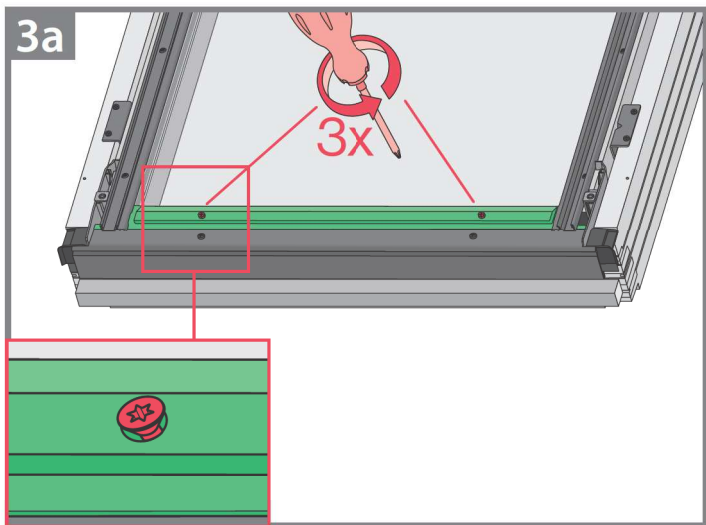

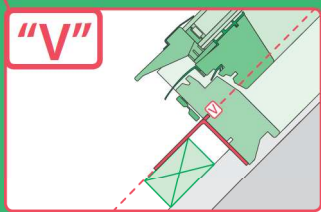
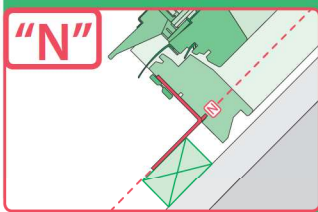
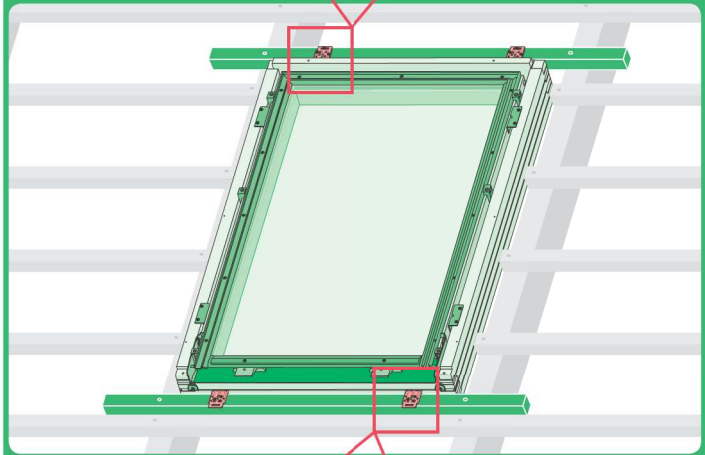
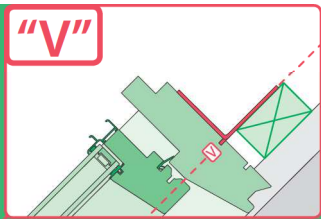
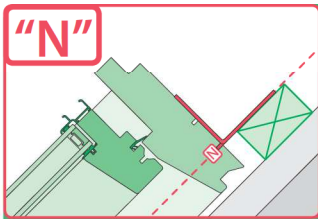

	<p>max 90mm</p>	<p>EHN</p>	
		<p>EHV</p>	
		-	-
	<p>max 45mm</p>	<p>EZN</p>	
		<p>EZV</p>	
		-	-
	<p>max 15mm (N) max 5mm (V)</p>	<p>ELN</p>	
		<p>ELV</p>	
		-	-
	<p>max 5mm</p>	<p>ESN</p>	
		<p>ESV</p>	
		-	-

1



"N"

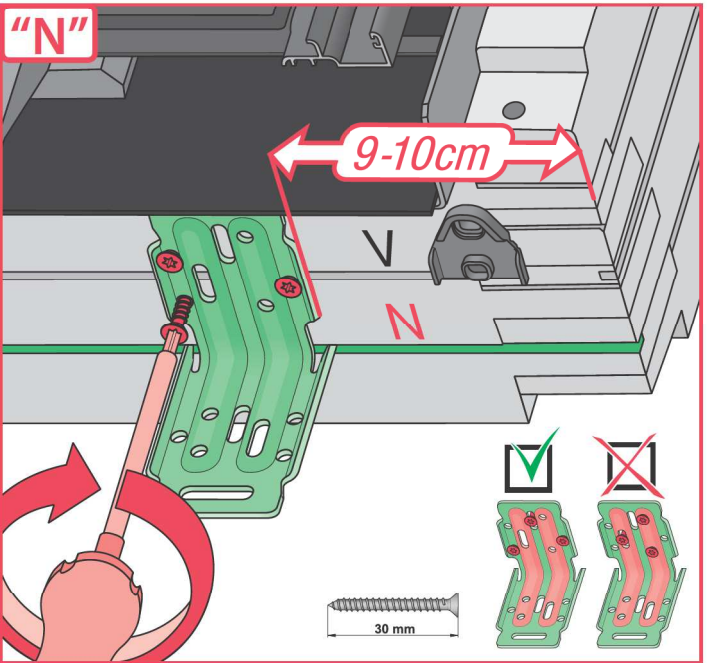

"V"

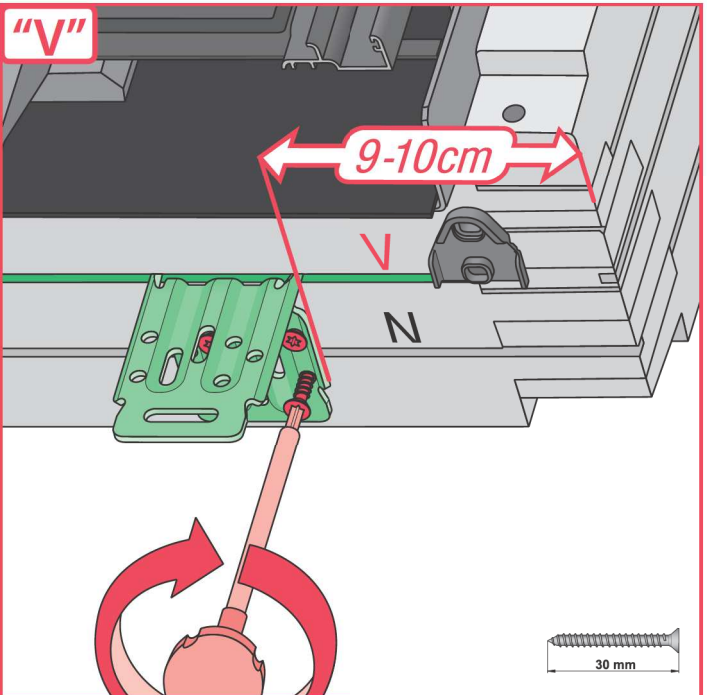

2

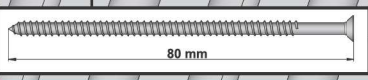
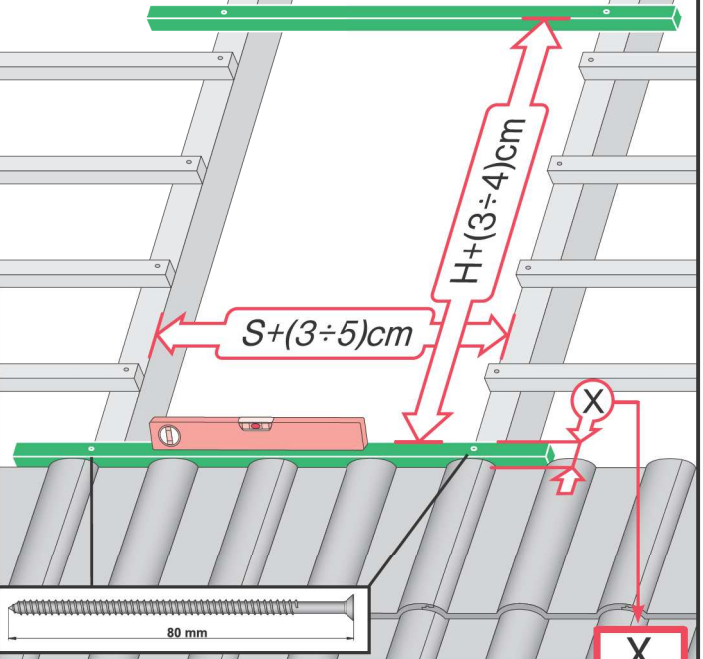

X	
EHN	7-10cm
EHV	7-10cm
EZN	6-8cm
EZV	6-8cm
EGV	6cm
EPV	6cm
ELN	0-2cm
ELV	0-2cm
EEN	0-2cm
EEV	0-2cm

	max 90mm	EHN	7-10cm
	max 45mm	EZN	6-8cm
	12-16mm	EGV	6cm
	12-16mm	EPV	6cm
	max 5mm (V) max 15mm (N)	ELN	0-2cm
	max 5mm (V) max 15mm (N)	ELV	0-2cm
		EEN	0-2cm
		EEV	0-2cm

ELN, ELV

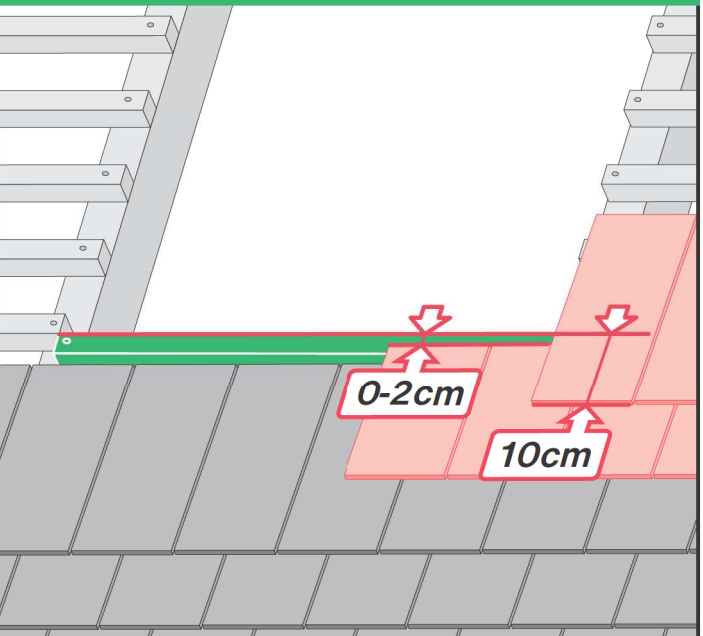

3

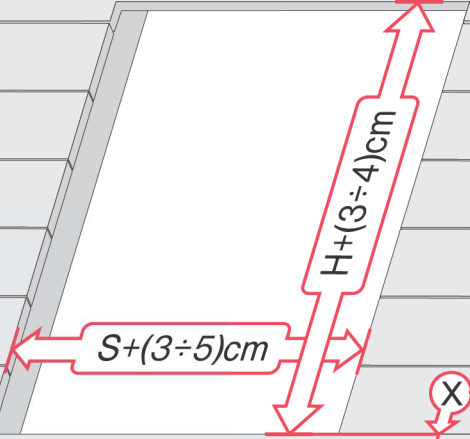
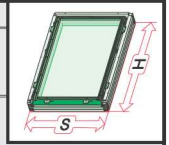

ESN	0-2cm
ESV	0-2cm

X

ESN, ESV

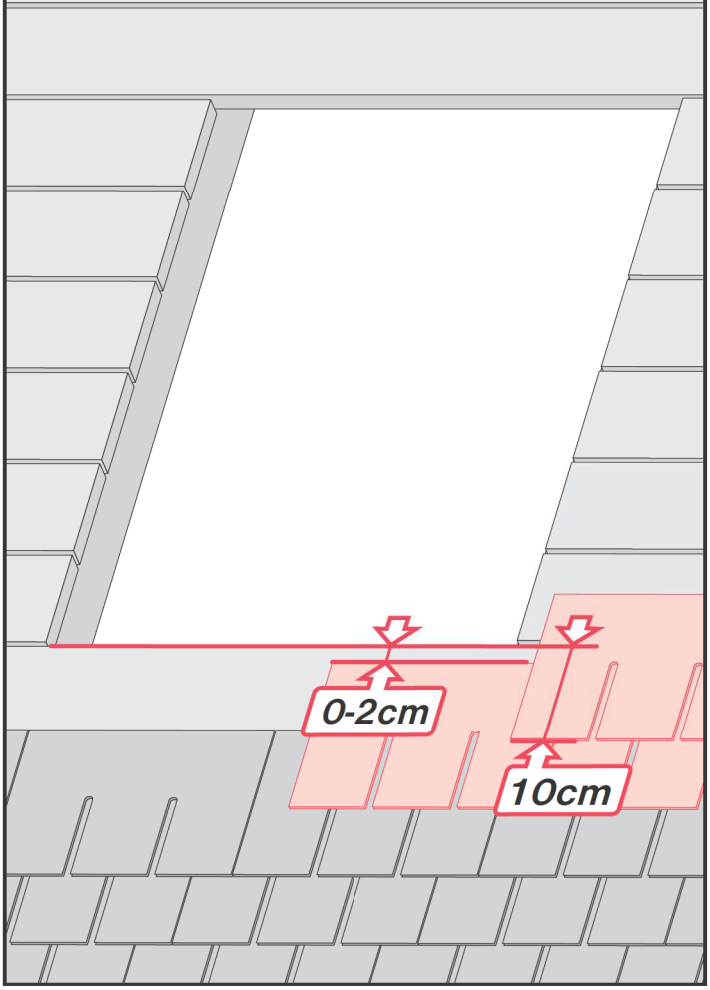

6

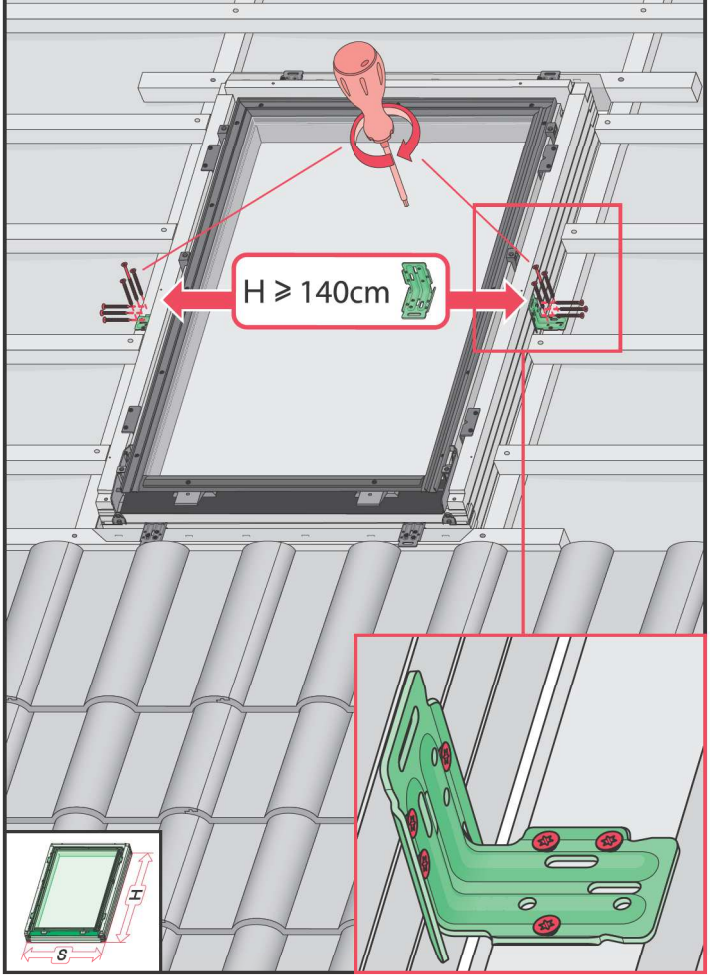
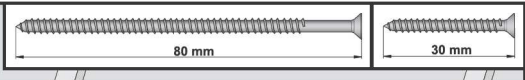

7

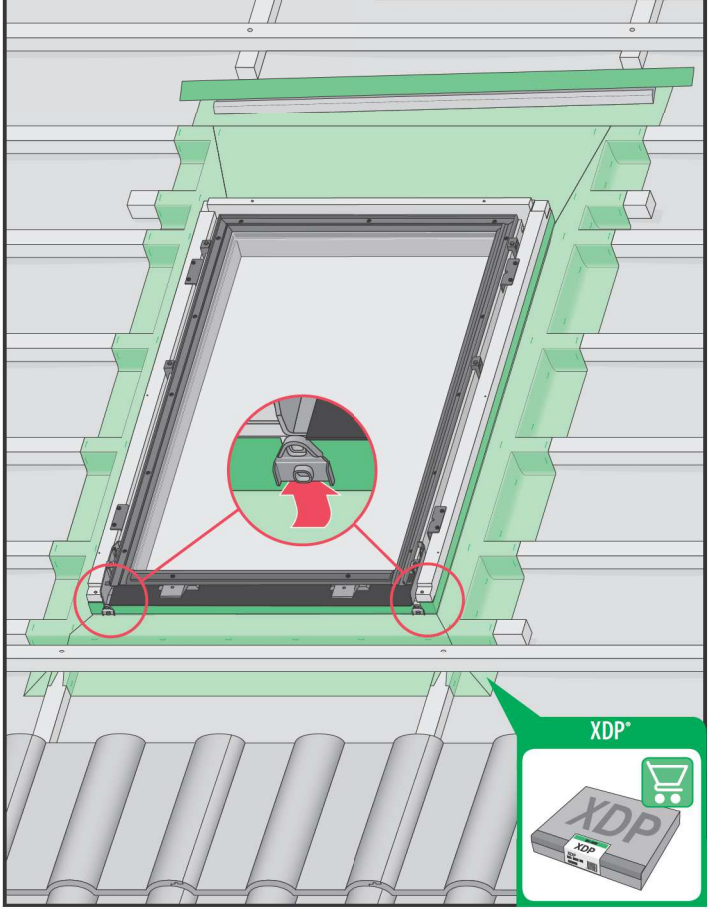
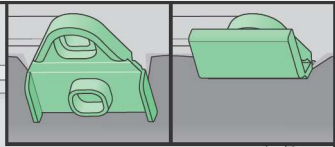

7*

25 mm

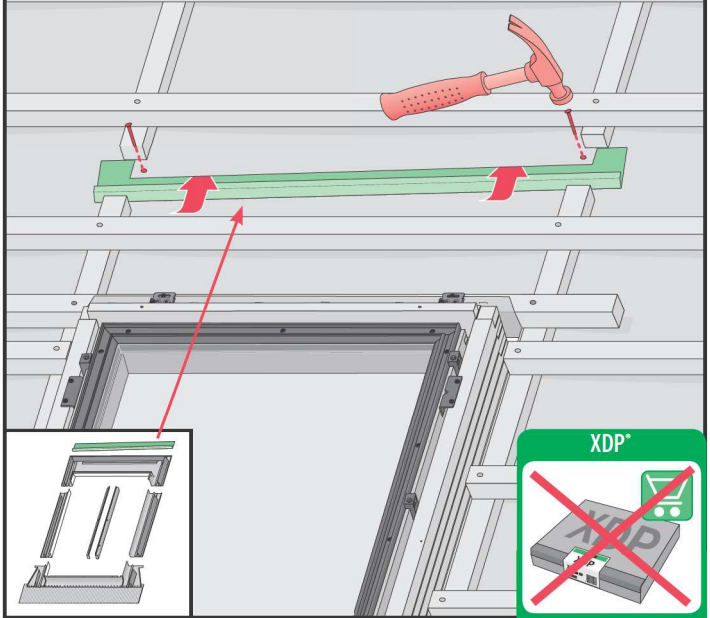

8

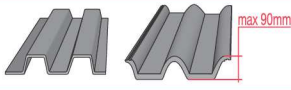
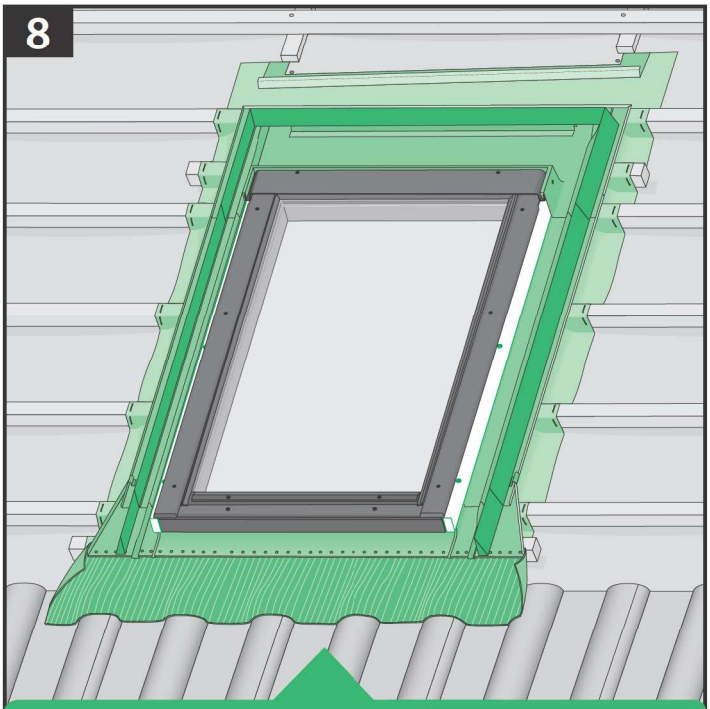

EHN
EHV

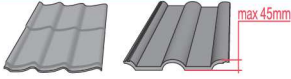

EZN
EZV



ESN
ESV



EGV



EPV

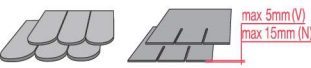

ELN
ELV

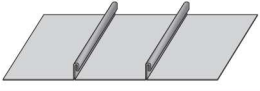

EEN
EEV

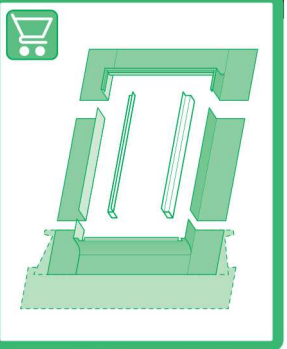

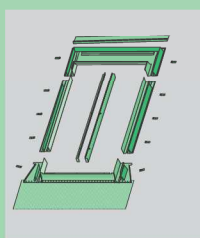
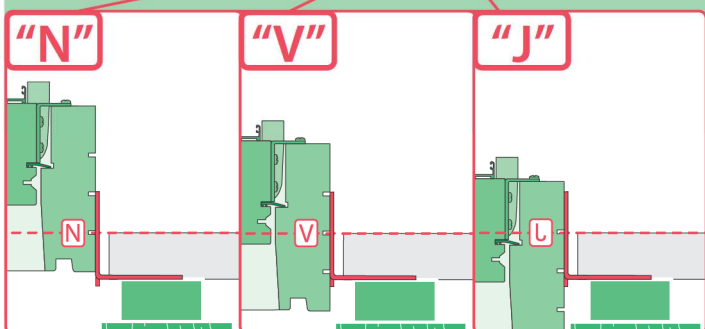
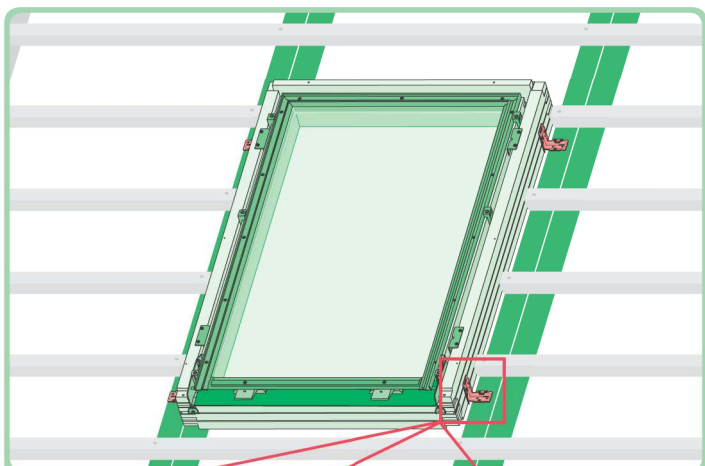
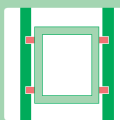

max 90mm

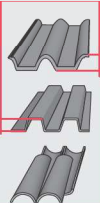

EHN

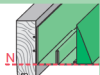

EHV

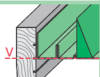

-

-

-

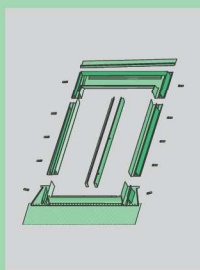

max 45mm

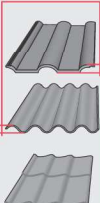

EZN

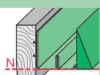

EZV

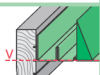

EZJ

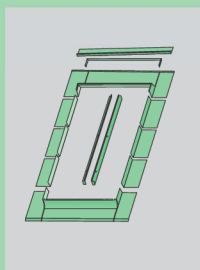
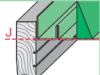

max 15mm (N)
max 5mm (V)
max 5mm (J)

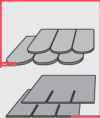

ELN

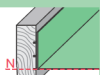

ELV

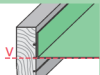

ELJ

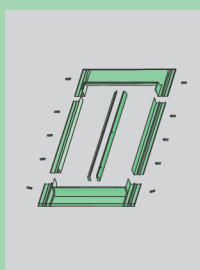
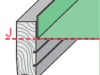

max 5mm



ESN

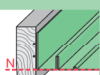

ESV

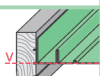

ESJ

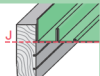

1

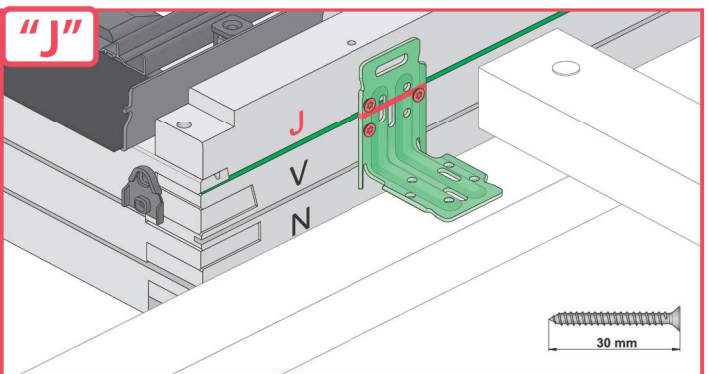
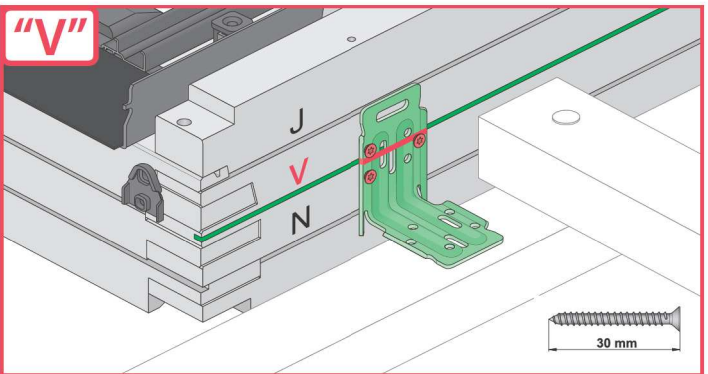
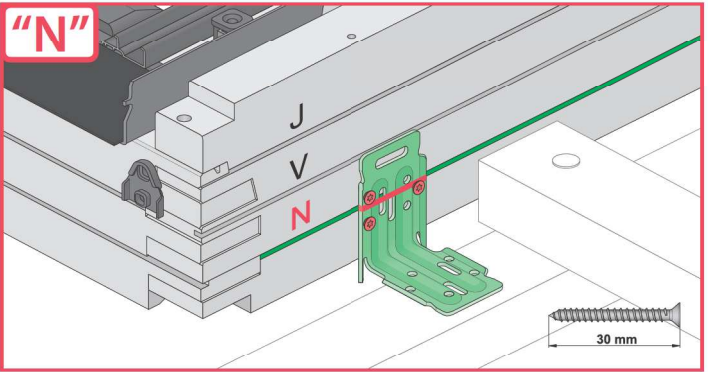
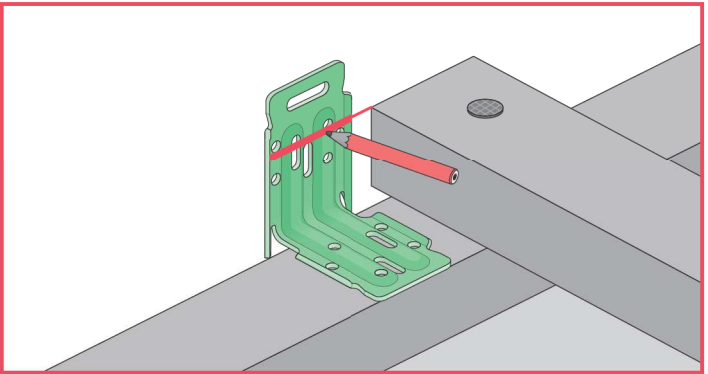
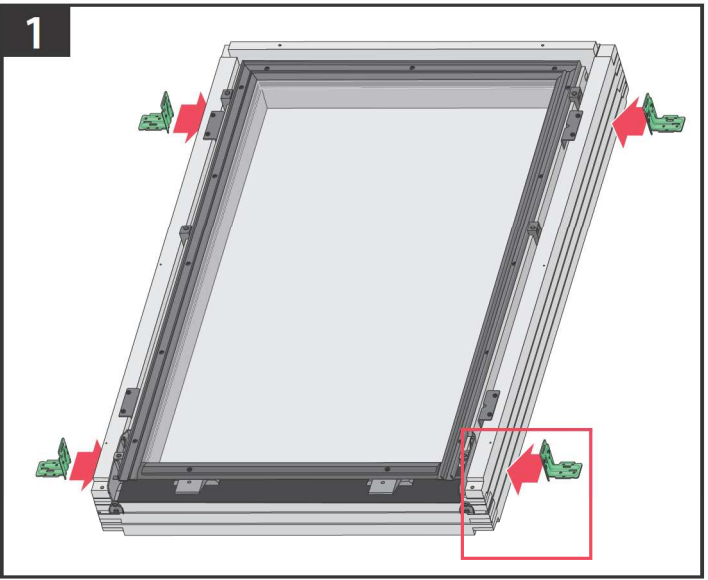

2

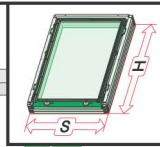

$S+(3\div 5)cm$

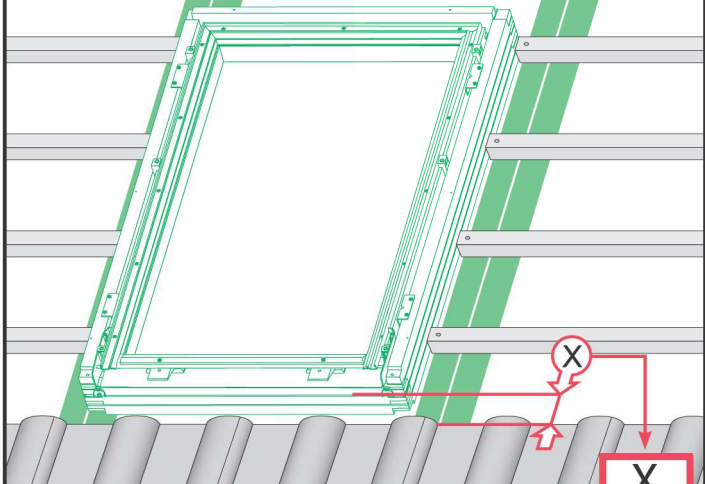

X	
EHN	9-12cm
EHV	9-12cm
EZN	8-10cm
EZV	8-10cm
EZJ	20cm
EGV	6cm
EPV	8cm
ELN	0-4cm
ELV	0-4cm
ELJ	14cm
EEN	0-4cm
EEV	0-4cm
EEJ	14cm

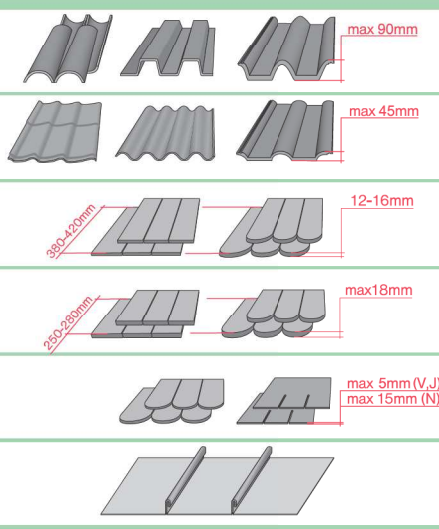

ELN, ELV

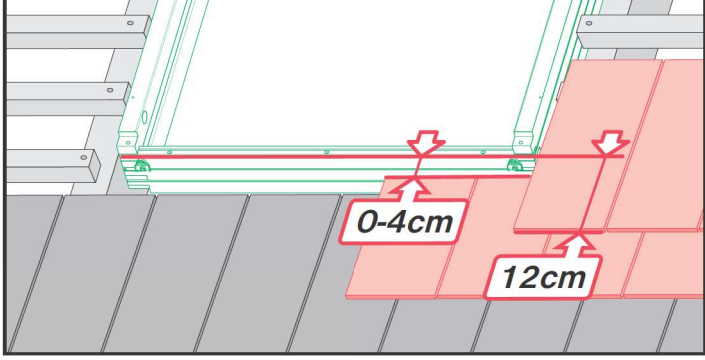

ELJ

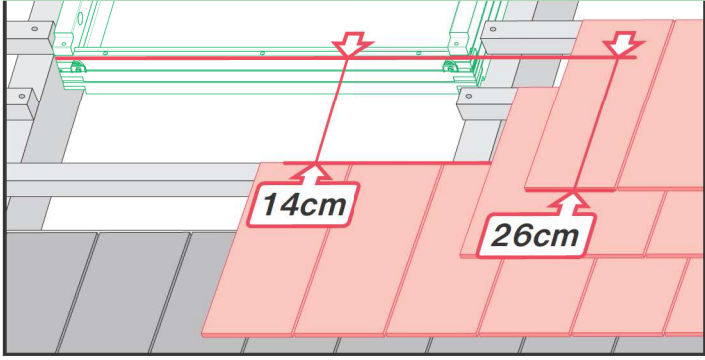

3

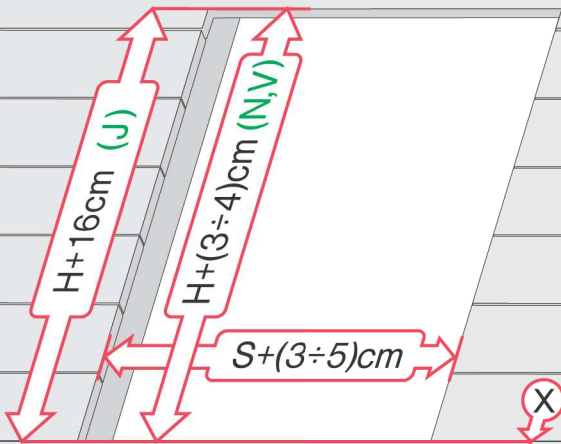
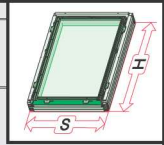

X
ESN 0-2cm
ESV 0-2cm
ESJ 0cm



ESN, ESV

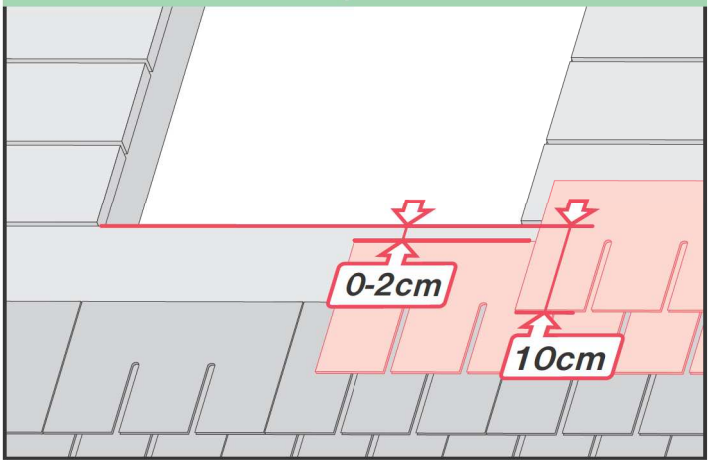

ESJ

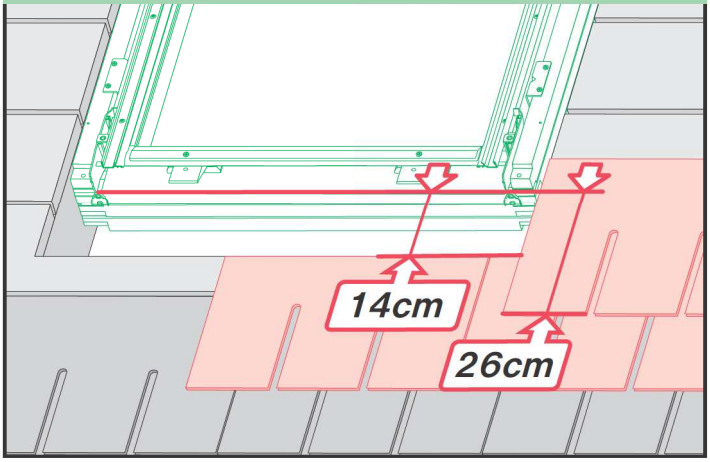

6

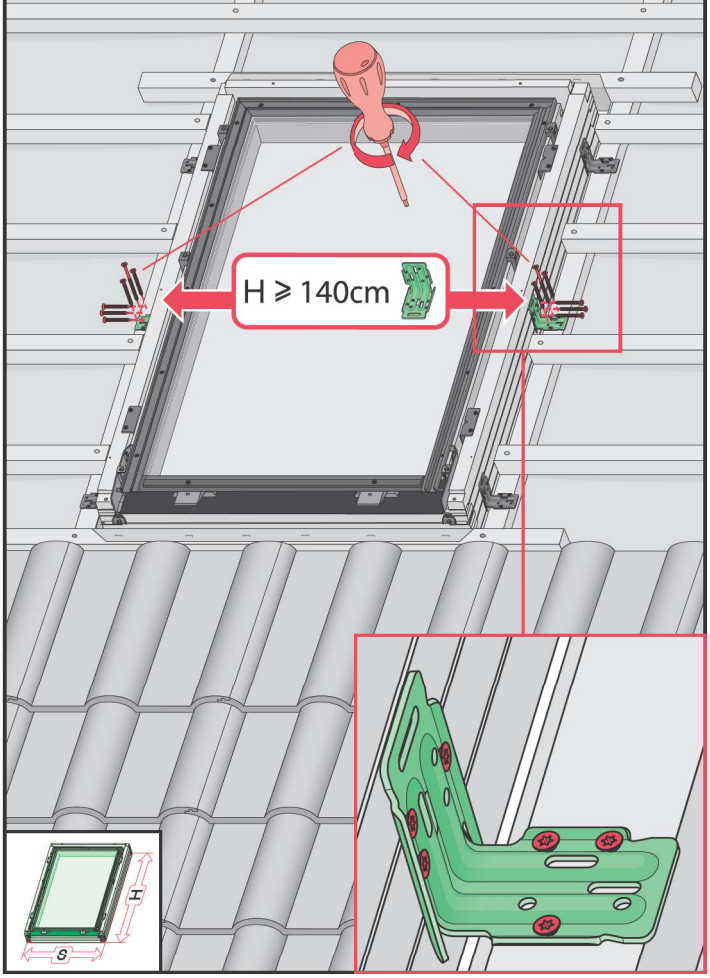
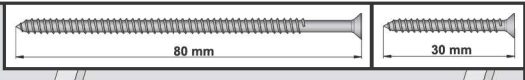

7

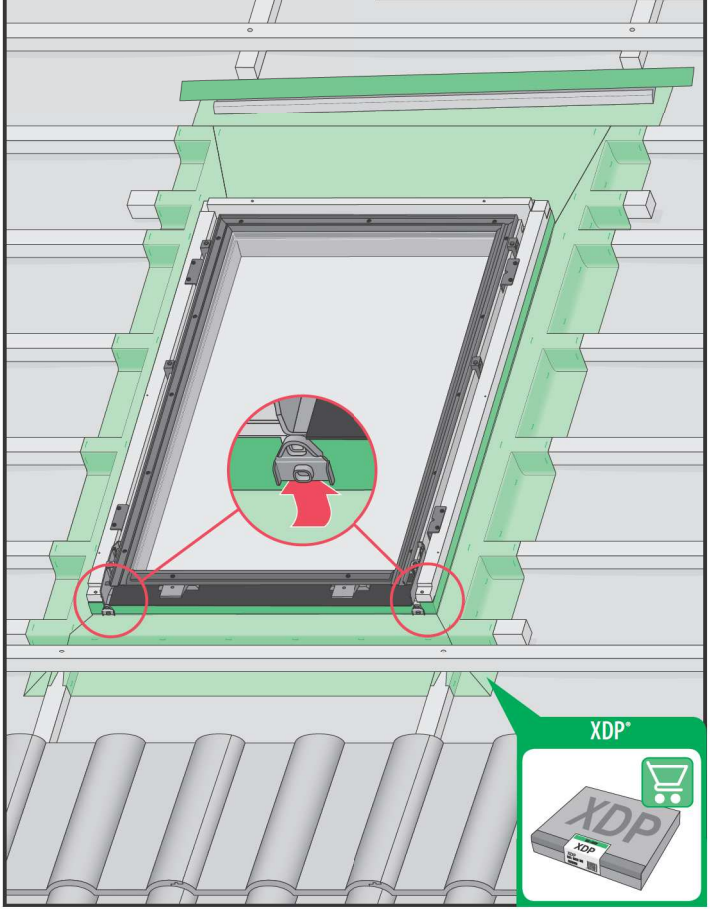
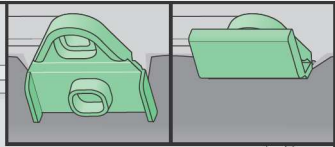

7*

25 mm

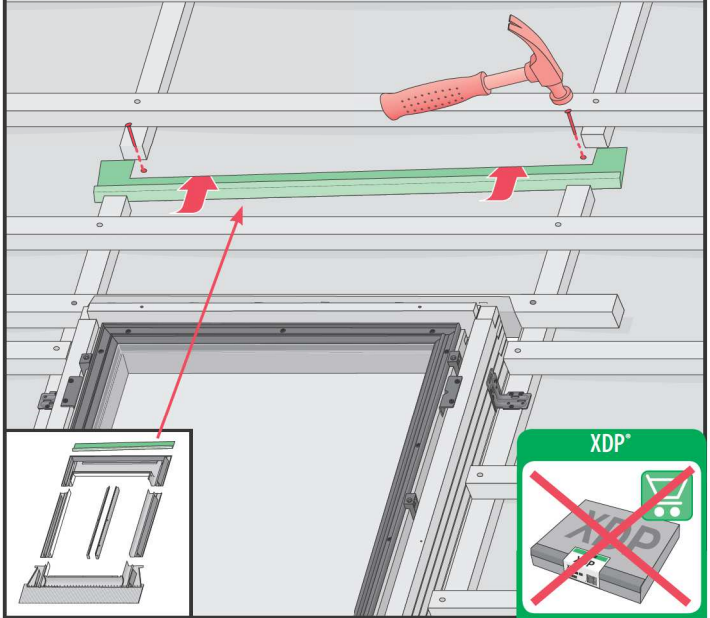

8

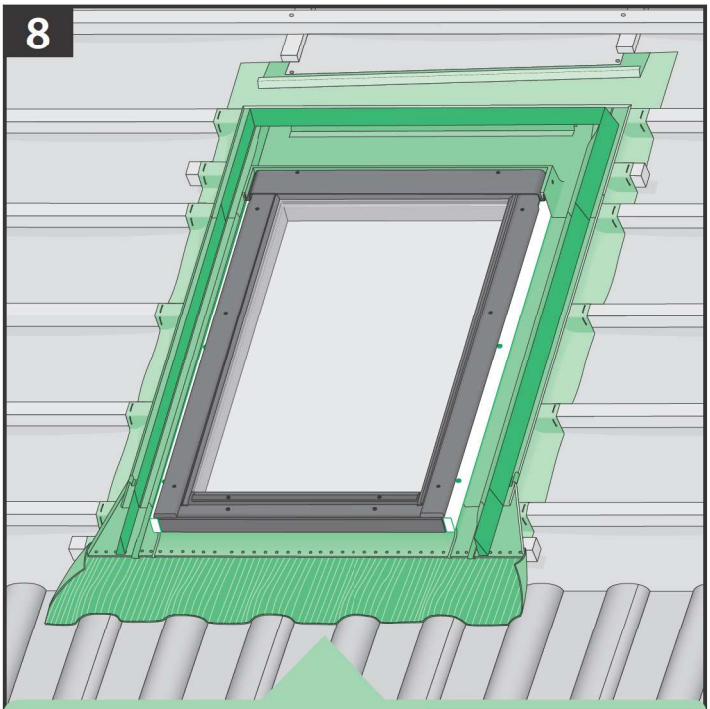

EHN
EHV

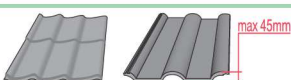

EZN
EZV
EZJ



ESN
ESV
ESJ



EGV



EPV

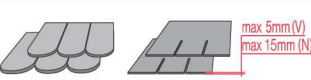

ELN
ELV
ELJ



EEN
EEV
EEJ

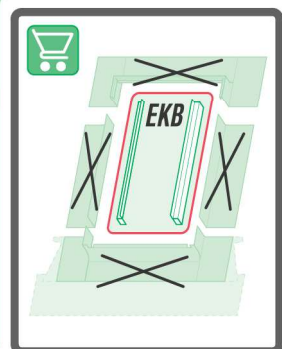
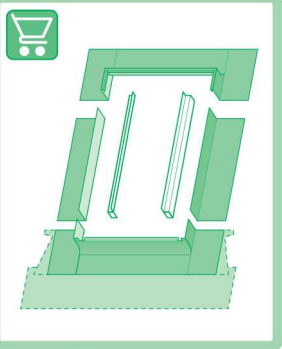



EH, EZ, EL, ES, ...

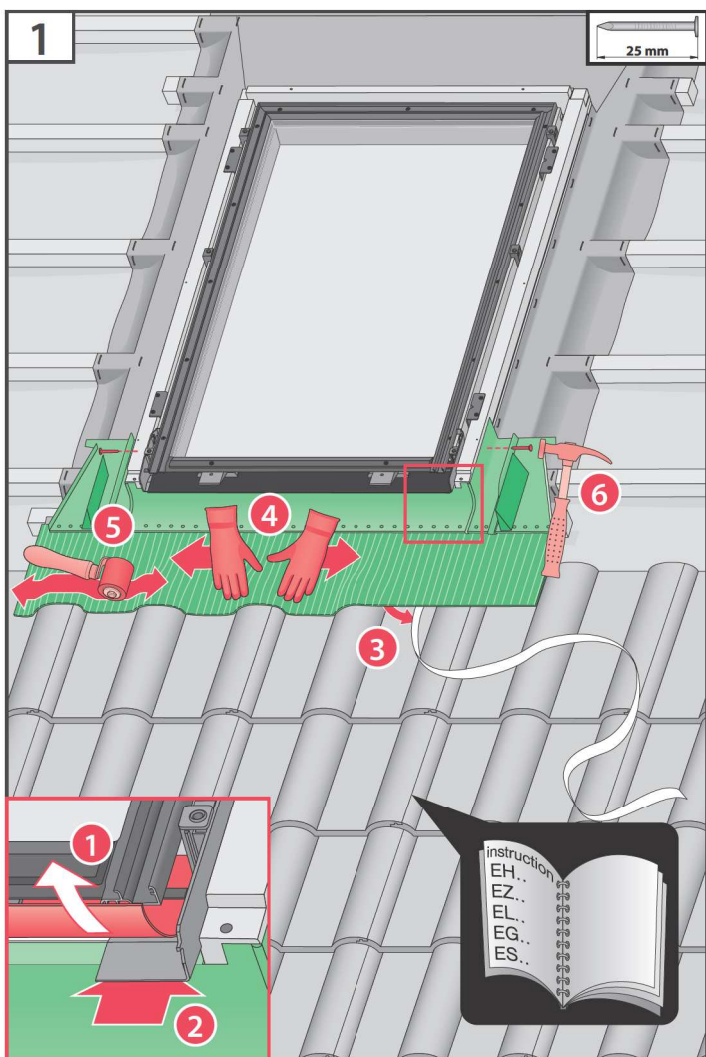
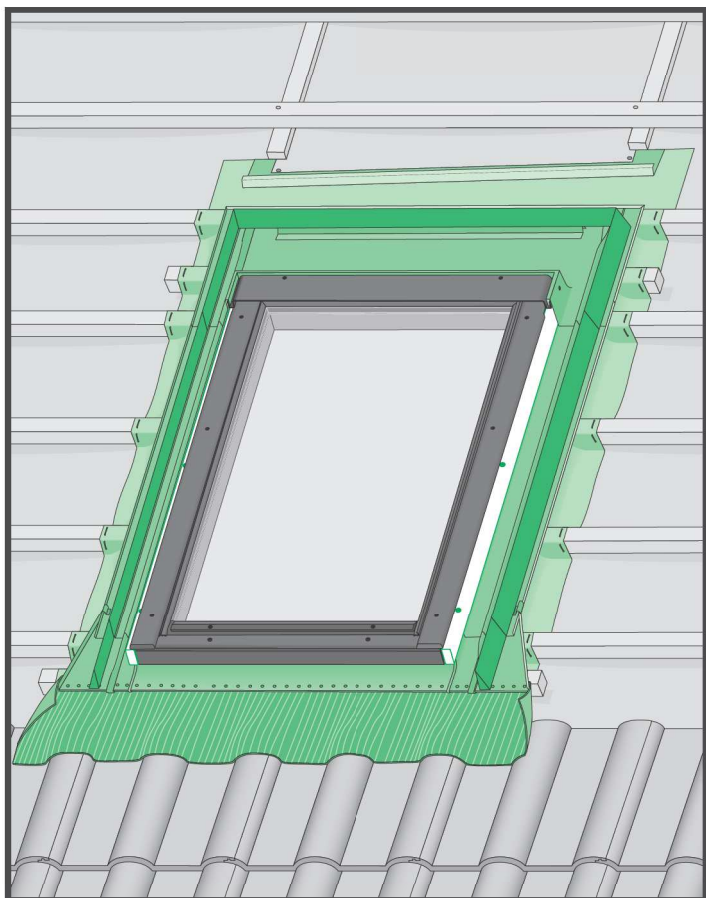

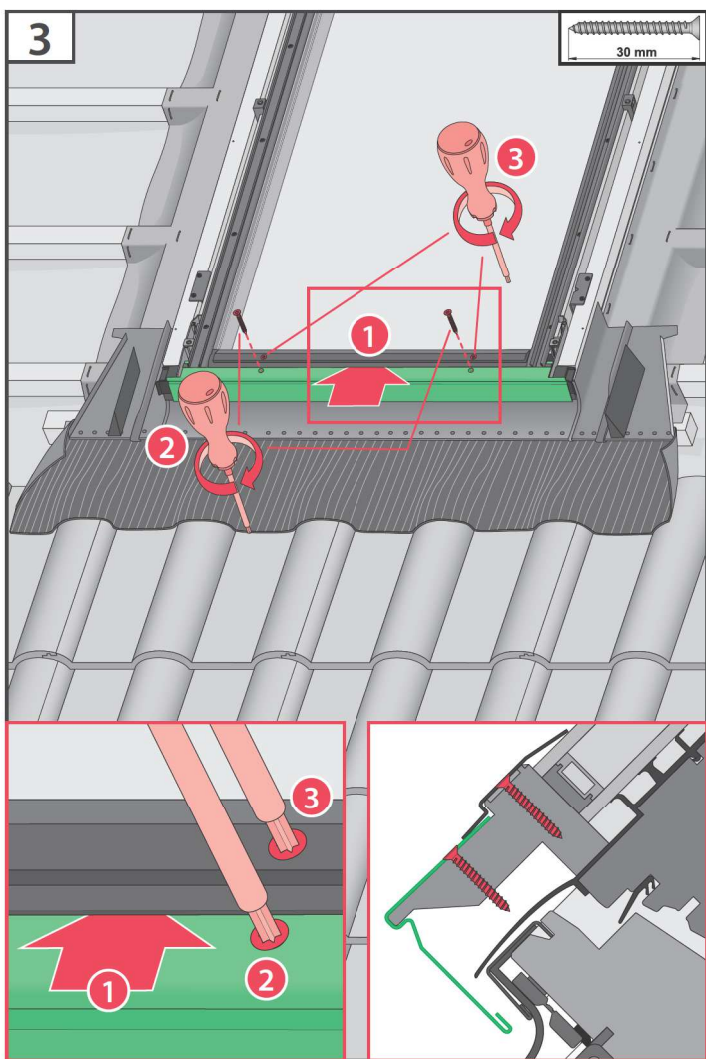
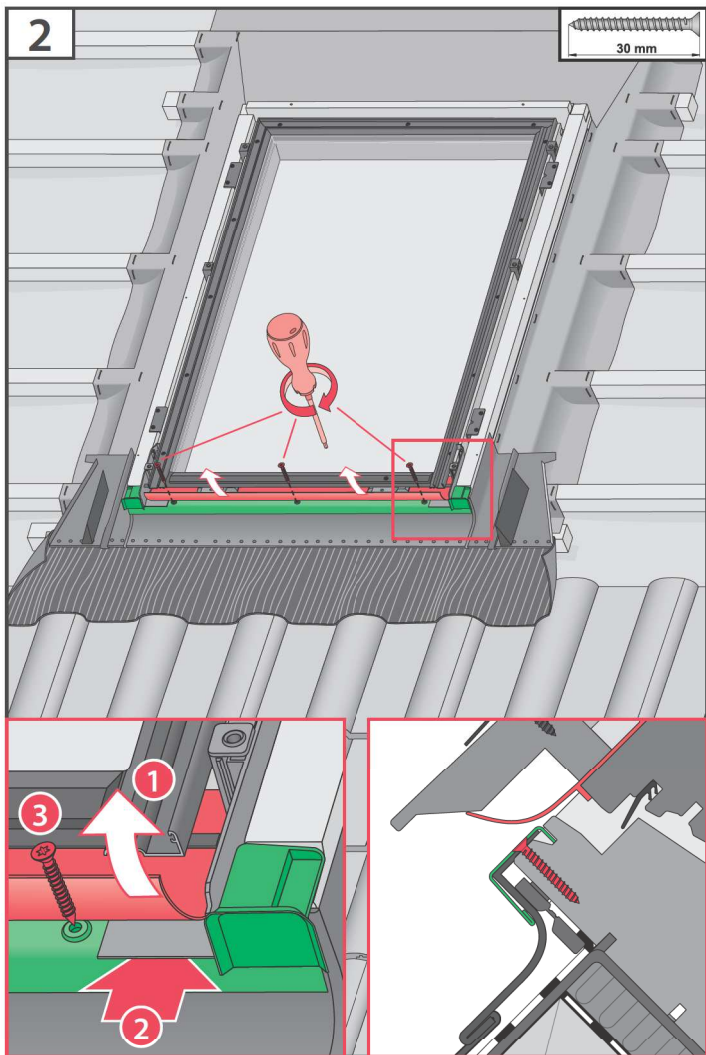

4

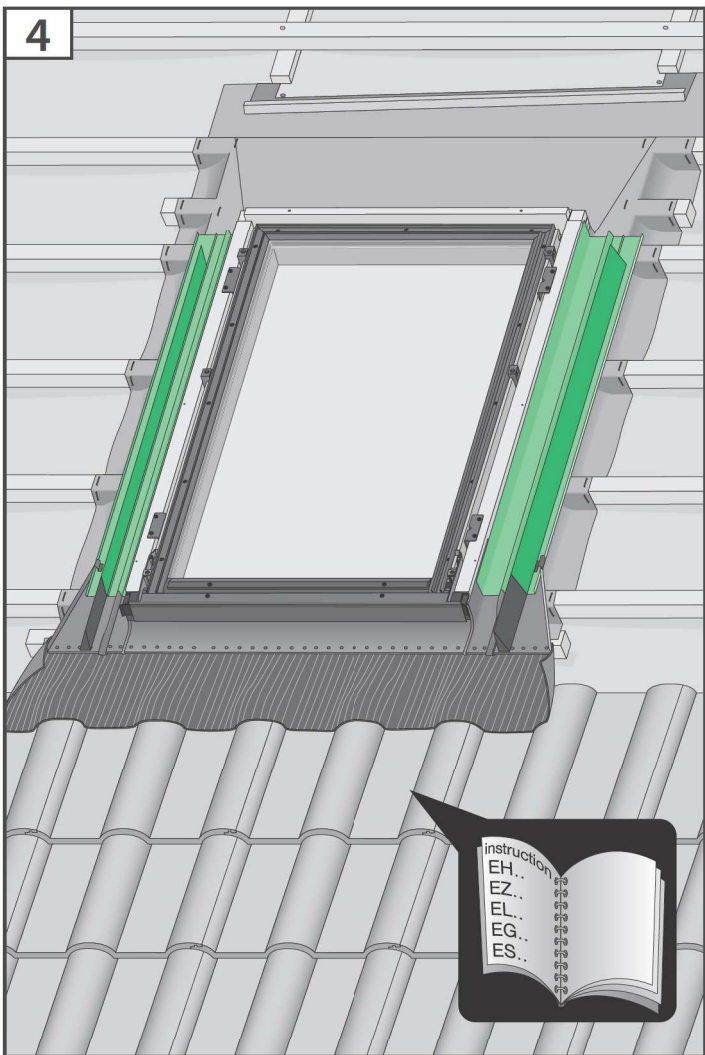

5

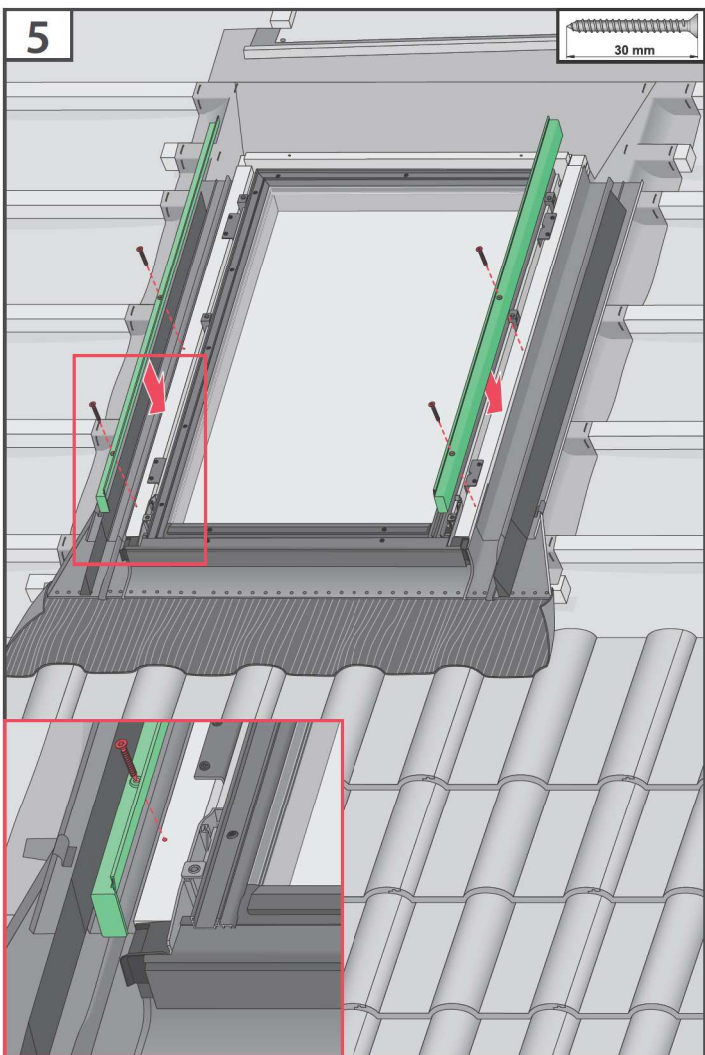

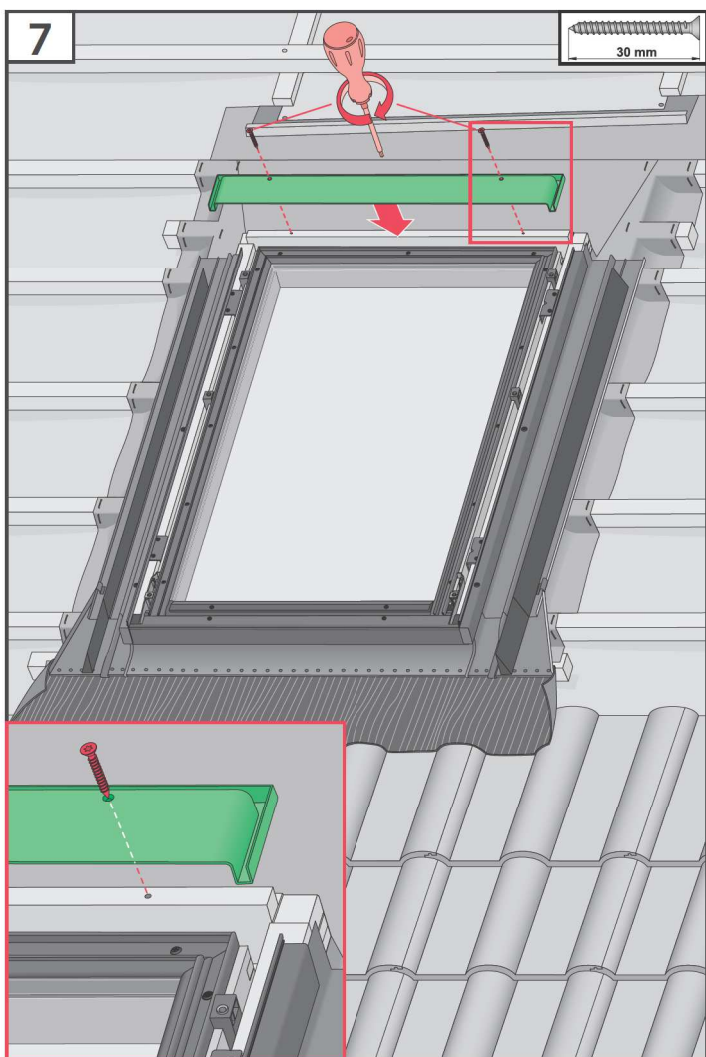
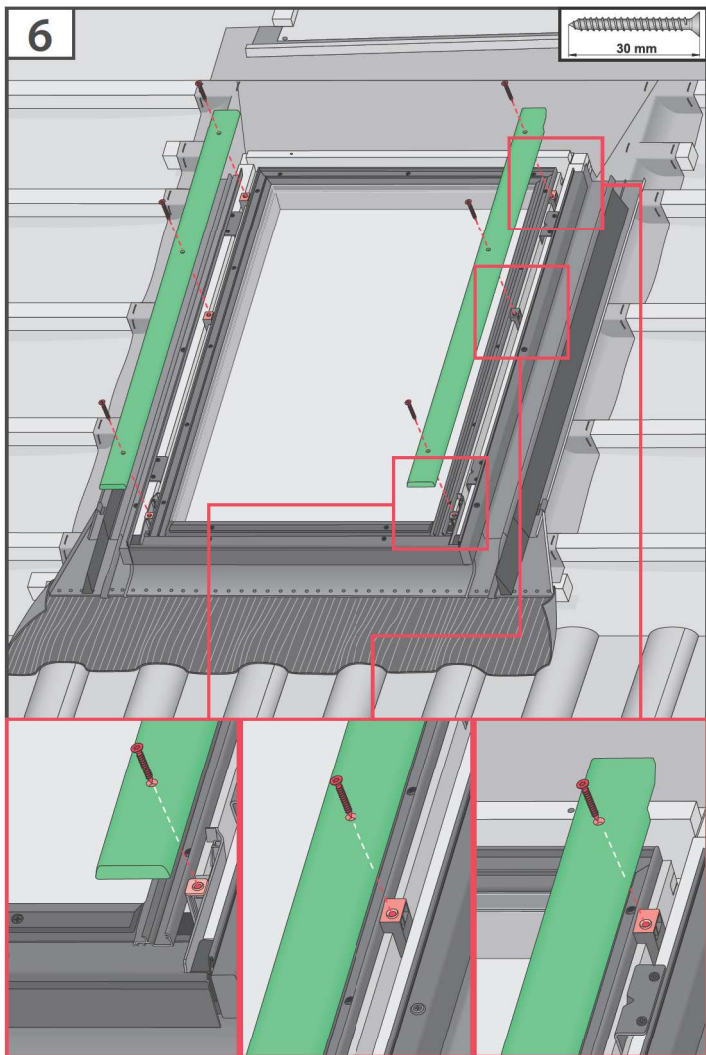

8

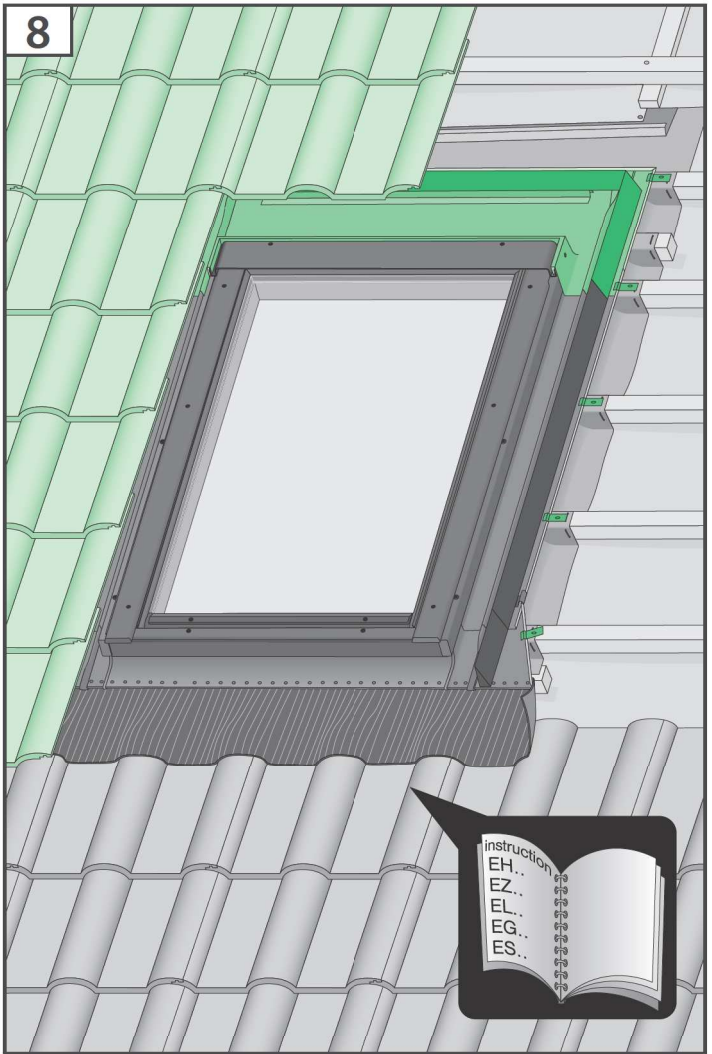

0 [cm] 1 2 3 4 5 6 7 8 9 10 11 12 13 14 15 16 17 18 19 20

BG	Производител и Продавач не носят отговорност за неспазване на съответните закони, строителни норми и изисквания за безопасност от потребителя на продукта, архитекта, монтажника или собственика на сградата.	LT	Ražotąs un mazumtirgotąs neuzņemas atbildību par likumi, noteikumu un drošības prasību neievērošanu no produkta lietotāja, arhitekta, uzstādītāja vai ēkas īpašnieka puses.
CZ	Výrobce ani prodejce nenesou žádnou odpovědnost za nedodržení příslušných platných zákonů, stavebních předpisů a bezpečnostních požadavků uživatelem výrobku, architektem, montážníkem nebo vlastníkem budovy.	LV	Ģarantotājs ir pardavējs neņems nekādas atbildības uz tā, kad ģarantotājs, arhitekts, montāžists ar pastato saviņņikas nesaiļķo ģallojandū ištatumu, taisykli ir saugos reikavimū.
DE	Hersteller und Verkäufer übernehmen keine Haftung für Nichtbeachtung entsprechender Rechts- und Bauvorschriften sowie Sicherheitsanforderungen seitens Produktbenutzers, Architekten, Monteure oder Gebäudebesitzers.	NL	De fabrikant en verkoper zijn niet aansprakelijk voor gevolgen bij het niet opvolgen van toepasselijke wetten, bouwbesluiten en veiligheidsvoorschriften door de gebruiker van het product, de architect, de installateur of de eigenaar van het gebouw.
EE	Tootja ja jaemüüja ei vastuta toote kasutaja, arhitekti, paigaldaja või hoone omaniku poolt tehtavate seaduste, määruste ja ohutusnõuete mittejärgmise eest.	PL	Producent i Sprzedawca nie ponosi żadnej odpowiedzialności za nieprzestrzeżenie stosownych przepisów prawa, przepisów budowlanych i wymogów bezpieczeństwa przez użytkownika produktu, architekta, montażystę lub właściciela budynku.
ES	El fabricante y el vendedor no tienen ninguna responsabilidad por el incumplimiento de la ley vigente, normas de construcción y exigencias de seguridad por parte del usuario del producto, arquitecto, instalador o el propietario del edificio.	PT	O fabricante e o vendedor não tem nenhuma responsabilidade pelo o não cumprimento da lei, códigos de construção e as exigências de segurança por parte do usuário do produto, arquiteto, instalador ou proprietário do edifício.
FR	Le fabricant et le revendeur ne prend aucune responsabilité de ne pas respecter les lois applicables, les règlements sur les bâtiments et les exigences de sécurité par l'utilisateur du produit, l'architecte, l'installateur ou le propriétaire du bâtiment.	RO	Nici producătorul, nici distribuitorul nu își vor asuma niciun fel de răspundere pentru nerespectarea legilor în vigoare, a legilor din domeniul construcțiilor sau a măsurilor de siguranță impuse utilizatorilor produsului, arhitecților, montajorilor sau proprietarilor clădirii.
GB	Manufacturer and Seller shall bear no liability for failure to comply with the applicable laws, building codes and safety requirements by the user of the product, architect, fitter or owner of the building.	RU	В случае несоблюдения архитектором, монтажником или владельцем здания строительных правил и норм безопасности ответственность с производителя и продавца снимается.
HU	A Gyártó és a Forgalmazó nem vállal semmiféle felelősséget a vonatkozó törvények, építési és biztonsági előírások, termékvélemények, építész, beépítőmester vagy épülettulajdonos általi be nem tartásáért.	SK	Výrobca a predajca nenesú žiadnu zodpovednosť za nedodržanie príslušných ustanovení zákona, stavebných predpisov a bezpečnostných požiadaviek užívateľom výrobku, architektom, montážom alebo majiteľom objektu.
IT	Il Produttore e il Rivenditore non potranno essere ritenuti responsabili per il mancato rispetto, da parte dell'utente del prodotto, del progettista, dell'installatore o del proprietario dell'edificio, delle leggi vigenti, nonché dei regolamenti edilizi e di quelli relativi alla sicurezza.		